

FLUKE®

8842A

Digital Multimeter

Instruction Manual

PN 879309

Date December 1991

Rev.3 7/96

© 1999 Fluke Corporation, All rights reserved. Printed in USA
All product names are trademarks of their respective companies.

Table of Contents

Chapter	Title	Page
1	Introduction and Specifications.....	1-1
1-1.	INTRODUCTION.....	1-2
1-2.	THE 8842A DIGITAL MULTIMETER.....	1-2
1-3.	OPTIONS AND ACCESSORIES.....	1-2
1-4.	SPECIFICATIONS.....	1-3
2	Operating Instructions.....	2-1
2-1.	INTRODUCTION.....	2-2
2-2.	INSTALLATION.....	2-2
2-3.	Installing the Power-Line Fuse.....	2-2
2-4.	Connecting to Line Power.....	2-2
2-5.	Adjusting the Handle.....	2-3
2-6.	Rack Mounting Kits.....	2-3
2-7.	OPERATING FEATURES.....	2-4
2-8.	Power-Up Features.....	2-4
2-9.	Front and Rear Panel Features.....	2-4
2-10.	Display Features.....	2-8
2-11.	Error Messages.....	2-8
2-12.	Overrange Indication.....	2-10
2-13.	Diagnostic Self-Tests.....	2-10
2-14.	Ranging.....	2-10
2-15.	AUTORANGE.....	2-10
2-16.	MANUAL RANGE.....	2-11
2-17.	Triggering.....	2-11
2-18.	CONTINUOUS TRIGGER MODE.....	2-11
2-19.	EXTERNAL TRIGGER MODE.....	2-11
2-20.	Reading Rates and Noise Rejection.....	2-11
2-21.	Automatic Settling Time Delay.....	2-12
2-22.	External Trigger Input (Option -05 Only).....	2-12
2-23.	Sample Complete Output (Option -05 Only).....	2-12
2-24.	MAKING MEASUREMENTS.....	2-13
2-25.	Input Overload Protection Limits.....	2-13
2-26.	Measuring Voltage and Resistance.....	2-13
2-27.	Measuring Current.....	2-13

2-28.	Current Fuse Protection.....	2-13
2-29.	Offset Measurements	2-14
2-30.	EXTERNAL CLEANING.....	2-15

3 Remote Programming..... 3-1

3-1.	INTRODUCTION.....	3-3
3-2.	CAPABILITIES	3-3
3-3.	BUS SET-UP PROCEDURE	3-3
3-4.	AN OVERVIEW OF REMOTE OPERATION	3-4
3-5.	A NOTE ABOUT EXAMPLES.....	3-6
3-6.	DEVICE-DEPENDENT COMMAND SET	3-6
3-7.	Bn (Offset Commands)	3-9
3-8.	Cn (Calibration Commands)	3-9
3-9.	Dn (Display Commands).....	3-9
3-10.	Fn (Function Commands)	3-10
3-11.	Get Commands.....	3-10
3-12.	G0 (Get Instrument Configuration).....	3-12
3-13.	G1 (Get SRQ Mask).....	3-12
3-14.	G2 (Get Calibration Prompt).....	3-12
3-15.	G3 (Get User-Defined Message).....	3-13
3-16.	G4 (Get Calibration Status).....	3-13
3-17.	G5 (Get IAB Status).....	3-14
3-18.	G6 (Get YW Status)	3-14
3-19.	G7 (Get Error Status)	3-14
3-20.	G8 (Get Instrument Identification).....	3-14
3-21.	N (Numeric Entry Command).....	3-15
3-22.	Put Commands	3-15
3-23.	P0 (Put Instrument Configuration).....	3-15
3-24.	P1 (Put SRQ Mask).....	3-16
3-25.	P2 (Put Calibration Value).....	3-16
3-26.	P3 (Put User-Defined Message).....	3-17
3-27.	Rn (Range Commands)	3-17
3-28.	Sn (Reading Rate Commands)	3-17
3-29.	Tn (Trigger Mode Commands)	3-17
3-30.	Wn (Terminator Commands)	3-19
3-31.	X0 (Clear Error Register Command)	3-19
3-32.	Yn (Suffix Commands)	3-19
3-33.	Z0 (Self-Test Command)	3-19
3-34.	(Device-Clear Command)	3-20
3-35.	? (Single-Trigger Command)	3-20
3-36.	INPUT SYNTAX	3-20
3-37.	Definitions.....	3-20
3-38.	Input Processing.....	3-21
3-39.	Syntax Rules	3-23
3-40.	OUTPUT DATA	3-24
3-41.	Loading Output Data.....	3-24
3-42.	Types of Output Data.....	3-25
3-43.	Numeric Data and Error Messages.....	3-25
3-44.	MEASUREMENT DATA	3-25
3-45.	OVERRANGE INDICATION	3-26
3-46.	ERROR MESSAGES	3-26
3-47.	Status Data	3-26
3-48.	Output Priority	3-26
3-49.	SERVICE REQUESTS	3-27

3-50.	The Serial Poll Register	3-27
3-51.	The SRQ Mask	3-28
3-52.	INTERFACE MESSAGES	3-29
3-53.	Address Messages	3-29
3-54.	Universal Commands	3-29
3-55.	Addressed Commands.....	3-30
3-56.	TALK-ONLY MODE	3-30
3-57.	REMOTE CALIBRATION.....	3-31
3-58.	TIMING CONSIDERATIONS	3-31
3-59.	IMMEDIATE MODE COMMANDS	3-31
3-60.	EXAMPLE PROGRAMS	3-32
4	Measurement Tutorial.....	4-1
4-1.	INTRODUCTION.....	4-2
4-2.	DC VOLTAGE MEASUREMENT	4-2
4-3.	Circuit Loading Error.....	4-2
4-4.	Input Bias Current Error.....	4-3
4-5.	RESISTANCE MEASUREMENT	4-4
4-6.	2-Wire Ohms	4-4
4-7.	Correcting for Test Lead Resistance in 2-Wire Ohms	4-5
4-8.	4-Wire Ohms	4-5
4-9.	Applications of the Ohms Functions.....	4-7
4-10.	TESTING DIODES	4-7
4-11.	TESTING ELECTROLYTIC CAPACITORS	4-7
4-12.	A PRECISION CURRENT SOURCE.....	4-8
4-13.	DC CURRENT MEASUREMENT	4-8
4-14.	REDUCING THERMAL VOLTAGES	4-9
4-15.	AC VOLTAGE AND CURRENT MEASUREMENT	4-10
4-16.	True RMS Measurement	4-10
4-17.	Waveform Comparison	4-10
4-18.	Crest Factor	4-12
4-19.	AC-Coupled AC Measurements	4-12
4-20.	Combined AC and DC Measurements.....	4-13
4-21.	Bandwidth	4-13
4-22.	Zero-Input VAC Error.....	4-13
4-23.	MAKING ACCURATE MEASUREMENTS ON THE 20 mV AND 20 Ω RANGES	4-14
4-24.	MAKING ACCURATE HIGH-RESISTANCE MEASUREMENTS	4-15
5	Theory of Operation.....	5-1
5-1.	INTRODUCTION.....	5-3
5-2.	OVERALL FUNCTIONAL DESCRIPTION	5-3
5-3.	DETAILED CIRCUIT DESCRIPTION	5-4
5-4.	DC SCALING	5-4
5-5.	VDC Scaling	5-6
5-6.	VDC Protection.....	5-7
5-7.	mA DC Scaling	5-7
5-8.	Analog Filter	5-7
5-9.	TRACK/HOLD CIRCUIT	5-8
5-10.	Track Configuration	5-10
5-11.	Settling Configuration.....	5-11
5-12.	Hold Configuration	5-11
5-13.	Pre-Charge Configuration	5-11
5-14.	PRECISION VOLTAGE REFERENCE.....	5-11

5-15.	OHMS CURRENT SOURCE	5-12
5-16.	OHMS PROTECTION	5-13
5-17.	OHMS FUNCTIONS	5-13
5-18.	2-Wire Ohms	5-13
5-19.	4-Wire Ohms	5-15
5-20.	A/D CONVERTER	5-15
5-21.	Timing/Data Control	5-17
5-22.	Precision DAC	5-18
5-23.	A/D Amplifier	5-18
5-24.	Bootstrap Supplies	5-18
5-25.	DISPLAY	5-19
5-26.	KEYBOARD	5-19
5-27.	DIGITAL CONTROLLER	5-19
5-28.	In-Guard Microcomputer	5-21
5-29.	Function and Range Control	5-23
5-30.	A/D Control and Computation	5-23
5-31.	Calibration Correction	5-23
5-32.	Keyboard/Display Control	5-24
5-33.	Troubleshooting Modes	5-24
5-34.	Guard-Crossing Communication	5-24
5-35.	GUARD CROSSING	5-24
5-36.	POWER SUPPLY	5-25
5-37.	IEEE-488 INTERFACE (OPTION -05)	5-26
5-38.	Out-Guard Microcomputer	5-26
5-39.	Guard Crossing	5-26
5-40.	Bus Interface Circuitry	5-26
5-41.	Signal Conditioning	5-27
5-42.	IEEE-488 Interface Power Supply	5-27
5-43.	TRUE RMS AC (OPTION -09)	5-27
5-44.	VAC Scaling	5-27
5-45.	mA AC Scaling	5-28
5-46.	Frequency Response Trimming	5-28
5-47.	True RMS AC-to-DC Conversion	5-28

6 Maintenance **6-1**

6-1.	INTRODUCTION	6-3
6-2.	PERFORMANCE TEST	6-4
6-3.	Diagnostic Self-Tests	6-4
6-4.	DC Voltage Test	6-5
6-5.	AC Voltage Test (Option -09 Only)	6-7
6-6.	Resistance Test	6-8
6-7.	DC Current Test	6-9
6-8.	AC Current Test (Option -09 Only)	6-10
6-9.	CALIBRATION	6-10
6-10.	Basic Calibration Procedure	6-11
6-11.	INITIAL PROCEDURE	6-11
6-12.	A/D CALIBRATION	6-12
6-13.	OFFSET AND GAIN CALIBRATION	6-14
6-14.	HIGH-FREQUENCY AC CALIBRATION	6-15
6-15.	Advanced Features and Special Considerations	6-16
6-16.	STORING VARIABLE INPUTS	6-16
6-17.	CALIBRATING INDIVIDUAL RANGES	6-17
6-18.	VERIFYING CALIBRATION	6-17
6-19.	ERASING CALIBRATION MEMORY	6-18

6-20.	TOLERANCE CHECK	6-18
6-21.	AC CALIBRATION AT OTHER FREQUENCIES	6-19
6-22.	OPTIMIZING USE OF THE 5450A.....	6-19
6-23.	Remote Calibration	6-20
6-24.	TIMING CONSIDERATIONS	6-23
6-25.	REMOTE ERASURE.....	6-24
6-26.	EXAMPLE CALIBRATION PROGRAM.....	6-24
6-27.	DISASSEMBLY PROCEDURE.....	6-25
6-28.	Case Removal.....	6-26
6-29.	True RMS AC PCA Removal (Option -09 Only).....	6-30
6-30.	IEEE-488 Interface PCA Removal (Option -05 Only)	6-30
6-31.	Main PCA Removal	6-30
6-32.	Front Panel Disassembly	6-32
6-33.	REASSEMBLY PROCEDURE	6-32
6-34.	INTERNAL FUSE REPLACEMENT	6-36
6-35.	EXTERNAL TRIGGER POLARITY SELECTION (Option -05 Only).....	6-36
6-36.	TROUBLESHOOTING	6-36
6-37.	Initial Troubleshooting Procedure.....	6-36
6-38.	Diagnostic Self-Tests	6-41
6-39.	Self-Test Descriptions.....	6-42
6-40.	Digital Controller Troubleshooting.....	6-45
6-41.	IN-GUARD MICROCOMPUTER SYSTEM	6-45
6-48.	DISPLAY SYSTEM.....	6-49
6-59.	ANALOG CONTROL SIGNALS	6-51
6-62.	DC Scaling Troubleshooting.....	6-54
6-63.	Track/Hold Troubleshooting.....	6-56
6-64.	Ohms Current Source Troubleshooting.....	6-56
6-65.	Precision Voltage Reference Troubleshooting.....	6-58
6-66.	A/D Converter Troubleshooting.....	6-59
6-67.	Power Supply Troubleshooting.....	6-61
6-68.	IEEE-488 Interface Troubleshooting (Option -05)	6-64
6-69.	SERVICE POSITION.....	6-64
6-70.	DIAGNOSTIC PROGRAM	6-64
6-71.	True RMS AC Troubleshooting (Option -09).....	6-66
6-72.	SERVICE POSITION.....	6-66
6-73.	MAJOR PROBLEMS.....	6-67
6-74.	MORE OBSCURE PROBLEMS	6-69
6-75.	Guard Crossing Troubleshooting	6-70
6-76.	INTERNAL CLEANING.....	6-70
6-77.	Cleaning Printed Circuit Assemblies	6-70
6-78.	Cleaning After Soldering	6-71
7	List of Replaceable Parts.....	7-1
7-1.	INTRODUCTION.....	7-3
7-2.	HOW TO OBTAIN PARTS.....	7-3
7-3.	MANUAL STATUS INFORMATION.....	7-3
7-4.	NEWER INSTRUMENTS.....	7-4
7-5.	SERVICE CENTERS.....	7-4
8	Options and Accessories	8-1
8-1.	INTRODUCTION.....	8-3
8-2.	ACCESSORIES	8-4
8-3.	Rack-Mount Kits (Y8834, Y8835 and Y8836).....	8-4
8-4.	Shielded IEEE-488 Interface Cables (Y8021, Y8022, and Y8023).....	8-4

8-5.	Replacement Test Leads (TL70A)	8-4
8-6.	Deluxe Test Lead Kits (Y8134)	8-4
8-7.	Slim-Flex Test Leads (Y8140).....	8-4
8-8.	Temperature Probes (80T-150U, and 80TK.)	8-4
8-9.	RF Probes (85RF and 83RF).....	8-4
8-10.	Current Shunt (80J-10).....	8-5
8-11.	Current Probes (Y8100, Y8101, 80i-400 and 80i-600).....	8-5
8-12.	High Voltage Probes (80K-6 and 80K-40)	8-5
805	Option –05 IEEE-488 Interface.....	805-1
805-1.	INTRODUCTION.....	805-3
805-2.	CAPABILITIES	805-3
805-3.	EXTERNAL CONTROLS.....	805-3
805-4.	INSTALLATION	805-3
805-5.	PROGRAMMING INSTRUCTIONS	805-4
805-6.	MAINTENANCE.....	805-4
805-7.	LIST OF REPLACEABLE PARTS	805-4
809	Option –09 True RMS AC.....	809-1
809-1.	INTRODUCTION.....	809-3
809-2.	INSTALLATION	809-3
809-3.	OPERATING INSTRUCTIONS.....	809-4
809-4.	MAINTENANCE.....	809-4
809-5.	LIST OF REPLACEABLE PARTS	809-4
9	Schematic Diagrams.....	9-1

List of Tables

Table	Title	Page
2-1.	Error Codes	2-9
2-2.	Input Overload Limits.....	2-13
3-1.	Status Data	3-11
3-2.	Numeric Output Data Format	3-25
3-8.	Serial Poll Register	3-28
3-3.	Immediate-Mode Commands for Various Controllers	3-32
3-4.	ASCII/IEEE Std 488-1978 Bus Codes	3-49
4-1.	Ohms Test Current.....	4-6
5-1.	Sample Rates and Reading Rates.....	5-23
6-1.	Recommended Test Equipment	6-3
6-2.	DC Voltage Test	6-6
6-3.	Low- and Mid-Frequency AC Voltage Test	6-7
6-4.	High-Frequency AC Voltage Test	6-8
6-5.	Resistance Test	6-9
6-6.	DC Current Test.....	6-9
6-7.	AC Current Test.....	6-10
6-8.	A/D Calibration Steps.....	6-13
6-9.	A/D Calibration Verification Test	6-13
6-10.	Offset and Gain Calibration Steps	6-14
6-11.	High-Frequency AC Calibration Steps	6-16
6-12.	Prompts When Calibrating Individual Ranges.....	6-17
6-13.	Tolerance Limits	6-19
6-14.	Commands Used During remote Calibration.....	6-21
6-15.	Error Numbers Which Are Displayed When Commands Are Not Valid	6-23
6-16.	Overall State Table	6-38
6-17.	Circuitry Tested by the Analog Self-Tests.....	6-40
6-18.	Self-Test Voltages.....	6-42
6-19.	Keyboard Wiring	6-51
6-20.	Analog Control Devices.....	6-52
6-21.	Analog Control Logic States.....	6-53
6-22.	DC Scaling and Track/Hold Supply Voltages	6-55
6-23.	Power Supply Voltages.....	6-63
6-24.	Diagnostic Modes	6-65
6-25.	I/O Port Configurations	6-66
6-26.	Isolating a Defective AC Stage.....	6-67

6-27. AC Signal Tracing	6-68
6-28. Truth Table for U804 and K2	6-69
7-1. 8842A Digital Multimeter.....	7-5
7-2. A1 Main PCA	7-10
7-3. A2 Display PCA	7-14
8-1. Accessories	8-3
8-2. Options.....	8-3
805-1. Option -05A IEEE-488 Interface PCA	805-7
809-1. Option -09 True RMS AC PCA.....	809-6

List of Figures

Figure	Title	Page
1-1.	External Dimensions	1-11
2-1.	Line Voltage Selection Settings	2-2
2-2.	Adjusting the Handle	2-3
2-3.	Rack-Mount Kits.....	2-3
2-4.	Installing the Single Rack Mount Kit	2-4
2-5.	Front Panel Features	2-5
2-6.	Rear Panel Features	2-7
2-7.	Typical Error Messages	2-8
2-8.	Overrange Indication	2-12
2-9.	Measuring Voltage and Resistance	2-15
2-10.	Measuring Current	2-15
3-1.	IEEE-488 Address Selection.....	3-4
3-2.	Remote Operation Block Diagram.....	3-5
3-3.	Typical Command String	3-6
3-4.	Commands Which Correspond to the Front Panel.....	3-7
3-5.	Device-Dependent Command Set.....	3-8
3-6.	Output Data Format	3-10
3-6.	Trigger Selection Logic Diagram	3-18
3-7.	Interpretation of Messages	3-22
3-9.	Example Program.....	3-33
3-10.	Example Program: Taking Readings with Local Control	3-34
3-11.	Example Program: Using the Serial Poll Register	3-35
3-12.	Example Program: Record Errors During Selftest.....	3-36
3-13.	Example Programs: Using the IBM PC	3-37
4-1.	Circuit Loading Error Calculation	4-2
4-2.	Measuring Input Bias Current Error	4-3
4-3.	Wire Ohms Measurement	4-4
4-4.	Wire Ohms Measurement	4-6
4-5.	Burden Voltage Error Calculation	4-9
4-6.	Waveform Comparison Chart	4-11
4-7.	Typical Crest Factors for Various Waveforms	4-12
4-8.	Combined AC and DC Measurement	4-13
4-9.	Reduction of Zero-Input Error	4-14
4-10.	Shielding for Low Voltage Measurements	4-15
4-11.	Shielding for Low Resistance Measurements	4-15

4-12.	Leakage Resistance in High Resistance Measurement	4-16
5-1.	Overall Functional Block Diagram.....	5-5
5-2.	DC Scaling (VDC and mA DC).....	5-6
5-3.	Track/Hold Amplifier	5-8
5-4.	Track/Hold Circuit Configurations	5-9
5-5.	Timing Diagram for One A/D Cycle	5-10
5-6.	Precision Voltage Reference.....	5-11
5-7.	Ohms Current Source.....	5-12
5-8.	Ohms Scaling.....	5-14
5-9.	Analog-to-Digital Converter.....	5-16
5-10.	First Remainder-Store Period	5-17
5-11.	Autozero Period	5-18
5-12.	Vacuum Fluorescent Display	5-19
5-13.	Digital Controller Block Diagram.....	5-20
5-14.	Read/Write Timing Diagrams for Internal Bus.....	5-22
5-15.	Guard Crossing Circuit	5-24
5-16.	IEEE-488 Interface Block Diagram.....	5-26
5-17.	True RMS AC Option Block Diagram	5-27
5-18.	True RMS AC-to-DC Converter.....	5-28
6-1.	DC Calibration Connections	6-6
6-2.	First A/D Calibration Prompt.....	6-11
6-3.	Calibration Functions.....	6-12
6-4.	Optimizing Use of the 5450A.....	6-20
6-5.	Example A/D Calibration Program.....	6-25
6-6.	8842A Disassembly	6-26
6-7.	Front Panel Disassembly.....	6-34
6-8.	Removing the Display Window	6-35
6-9.	U202 Pin Diagram	6-46
6-10.	Waveforms for In-Guard Troubleshooting Mode	6-47
6-11.	Waveforms for Display Logic	6-49
6-12.	Typical Dynamic Control Signals.....	6-54
6-13.	Typical Output Waveforms for Track/Hold Circuit (TP103)	6-57
6-14.	Output of A/D Amplifier (TP101)	6-59
6-15.	Waveforms at U101-24 and U101-25.....	6-60
6-16.	Typical Bus Data Line Waveform	6-60
6-17.	Waveforms at TP102 for Several Inputs on 2V DV Range.....	6-62
6-18.	Calculating the A/D Reading From TP102 Waveform.....	6-63
6-19.	Option -05 Service Position.....	6-65
6-20.	Option -09 Service Position.....	6-68
6-21.	Guard Crossing Test Waveforms.....	6-71
7-1.	8842A Digital Multimeter.....	7-6
7-2.	A1 Main PCA	7-13
7-3.	A2 Display PCA	7-15
7-4.	Service Centers	7-18
7-4.	Service Centers (cont).....	7-19
805-1.	Installing Option -05	805-5
805-2.	IEEE-488 Interface PCA.....	805-8
809-1.	Installing Option -09	809-5
809-2.	True RMS AC PCA	809-7
9-1.	Main PCA, DC Scaling and F/R Switch.....	9-3
9-2.	Main PCA, A/D Converter	9-5
9-3.	Main PCA, Ohms Current Source	9-7
9-4.	Main PCA, Digital	9-9
9-5.	Main PCA, Power Supply.....	9-11
9-6.	Display PCA	9-13

9-7. IEEE-488 Interface PCA, Option -05	9-15
9-8. True RMS AC PCA, Option -09.....	9-17

Chapter 1

Introduction and Specifications

	Title	Page
1-1.	INTRODUCTION.....	1-2
1-2.	THE 8842A DIGITAL MULTIMETER.....	1-2
1-3.	OPTIONS AND ACCESSORIES.....	1-2
1-4.	SPECIFICATIONS.....	1-3

1-1. INTRODUCTION

This manual provides complete operating instructions and service information for the 8842A. If you want to get started using your 8842A right away, proceed to the operating instructions in Section 2. If you intend to use the 8842A with the IEEE-488 Interface (Option -05), read Sections 2 and 3. This meter has been designed and tested according to IEC publication 348, Safety Requirements for Electronic Measuring Apparatus. This manual contains information and warnings which must be followed to ensure safe operation and retain the meter in safe condition.

1-2. THE 8842A DIGITAL MULTIMETER

The Fluke 8842A Digital Multimeter is a high-performance 5-1/2 digit instrument designed for general-purpose bench or systems applications. The 8842A is the top-of-the-line DMM in the 8840A family. Using proprietary thin film resistor networks, a stable reference amplifier and stable active components, the 8842A offers superior measurement performance and stability. It also offers additional 20 mV, 20 ohm, and 200 mA dc ranges. Features of the 8842A include:

- Highly legible vacuum fluorescent display
- Intuitively easy front panel operation
- Basic dc accuracy of 0.003% for 1 year
- 2-wire and 4-wire resistance measurement
- DC current measurement
- Up to 100 readings per second
- Closed-case calibration (no internal adjustments)
- Built-in self-tests

1-3. OPTIONS AND ACCESSORIES

A number of options and accessories are available for the 8842A which can be easily installed at any time. The options include:

- IEEE-488 Interface (Option -05), featuring:
 - Full programmability
 - Simple and predictable command set
 - Fast measurement throughput
 - External Trigger input connector
 - Sample Complete output connector
 - Automated calibration
 - Low cost
- True RMS AC (Option -09), featuring:
 - AC voltage measurement
 - AC current measurement

Accessories include a variety of rack mounting kits, probes, test leads, and cables. Full information about options and accessories can be found in Section 8.

1-4. SPECIFICATIONS

Specifications for the 8842A are given in Table 1-1. External dimensions are shown in Figure 1-1.

Table 1-1. Specifications

DC VOLTAGE
Input Characteristics

RANGE	FULL SCALE 5½ DIGITS	RESOLUTION		INPUT RESISTANCE
		5½ DIGITS	4½ DIGITS*	
20 mV	19.9999 mV	0.1µV	1 µV	≥10,000 MΩ
200 mV	199.999 mV	1µV	10 µV	≥10,000 MΩ
2V	1.99999V	10 µV	100 µV	≥10,000 MΩ
20V	19.9999V	100 µV	1 mV	≥10,000 MΩ
200V	199.999V	1 mV	10 mV	10 MΩ
1000V	1000.00V	10 mV	100 mV	10 MΩ

*4½ digits at the fastest reading rate.

Accuracy

NORMAL (S) READING RATE ±(% of Reading + Number of Counts)

RANGE	24 HOUR ¹ 23±1°C	90 DAY 23±5°C	1 YEAR 23±5°C	2 YEAR 23±5°C
20 mV ²	0.0050 + 2 ³	0.0070 + 3 ³	0.0100 + 3 ³	0.0120 + 4 ³
200 mV ²	0.0030 + 2 ⁴	0.0045 + 3 ⁴	0.0070 + 3 ⁴	0.0100 + 4 ⁴
2V	0.0015 + 2	0.0025 + 2	0.0030 + 2	0.0050 + 3
20V	0.0015 + 2	0.0030 + 2	0.0035 + 2	0.0060 + 3
200V	0.0015 + 2	0.0030 + 2	0.0035 + 2	0.0060 + 3
1000V	0.0020 + 2	0.0035 + 2	0.0045 + 2	0.0070 + 3

1. Relative to calibration standards.
2. Within one hour of dc zero, using offset control.
3. When offset control is not used the number of counts are 50, 70, 90 and 90 for 24 hours, 90 day, 1 year, and 2 year respectively.
4. When offset control is not used the number of counts are 5, 7, 9 for 24 hours, 90 day, 1 year, and 2 year respectively.

MEDIUM AND FAST RATES:In medium rate, add 3 counts (20 counts on 20 mV Range) to number of counts. In fast rate, use 2 (4½ digit mode) counts (30 counts on 20 mV range) for the number of counts

Operating Characteristics

TEMPERATURE COEFFICIENT $\pm(0.0006\%$ of reading + 0.3 Count) per °C from 0°C to 18°C and 28°C to 50°C.

MAXIMUM INPUT1000V dc or peak ac on any range.

NOISE REJECTION.....Automatically optimized at power-up for 50, 60, or 400 Hz.

RATE	READINGS/ SECOND ¹	FILTER	NMRR ²	PEAK NM SIGNAL	CMRR ³
S ⁵	2.5	Analog & Digital	>98 dB	20V or 2x FS ⁴	>140 dB
M ⁶	20	Digital	>45 dB	1x FS	>100 dB
F	100	None	–	1x FS	>60 dB

1. Reading rate with internal trigger and 60 Hz power line frequency. See "reading rates" for more detail.
2. Normal Mode Rejection Ratio, at 50 or 60 Hz $\pm 0.1\%$. The NMRR for 400 Hz $\pm 0.1\%$ is 85 dB in S rate and 35 dB in M rate.
3. Common Mode Rejection Ratio at 50 or 60 Hz $\pm 0.1\%$, with 1 k Ω in series with either lead. The CMRR is >140 dB at dc for all reading rates.
4. 20 volts or 2 times full scale whichever is greater, not to exceed 1000V.
5. Reading rate-1/3 rdg / sec. in the 20 mV, 20 Ω , 200 mA dc ranges
6. Reading rate-1.25 rdg / sec. in the 20 mV, 20 Ω , 200 mA dc ranges

TRUE RMS AC VOLTAGE (OPTION 8842A-09)**Input Characteristics**

RANGE	FULL SCALE 5½ DIGITS	RESOLUTION		INPUT IMPEDANCE
		5½ DIGITS	4½ DIGITS*	
200 mV	199.999 mV	1 μ V	10 μ V	1 M Ω
2V	1.99999V	10 μ V	100 μ V	Shunted
20V	19.9999V	100 μ V	1 mV	By
200V	199.999V	1 mV	10 mV	<100 pF
700V	700.00V	10 mV	100 mV	

*4½ digits at the fastest reading rate

Accuracy

NORMAL (s) READING RATE \pm (% of Reading + Number of Counts).

For sinewave inputs $\geq 10,000$ counts¹.

FREQUENCY	24 HOURS ² 23 \pm 1°C	90 DAY 23 \pm 5°C	1 YEAR 23 \pm 5°C	2 YEARS \pm 5°C
20-45	1.2 + 100	1.2 + 100	1.2 + 100	1.2 + 100
45-200	0.3 + 100	0.35 + 100	0.4 + 100	0.5 + 100
200-20k				
(200 mV range)	0.06 + 100	0.08 + 100	0.10 + 100	0.20 + 100
(2V-200V range)	0.05 + 80	0.07 + 80	0.08 + 80	0.15 + 80
(700V range)	0.06 + 100	0.08 + 100	0.10 + 100	0.20 + 100
20k-50k	0.15 + 120	0.19 + 150	0.21 + 200	0.25 + 250
50k-100k	0.4 + 300	0.5 + 300	0.5 + 400	0.5 + 500

1. For sinewave inputs between 1,000 and 10,000 counts, add to number of counts 100 counts for frequencies 20 Hz to 20 kHz, 200 counts for 20 kHz, and 500 counts for 50 kHz to 100 kHz.

2. Relative to calibration standards.

MEDIUM AND FAST READING RATES.....In medium rate, add 50 counts to number of counts. In the fast rate the specifications apply for sinewave inputs ≥ 1000 (4½ digit mode) counts and >100 Hz.

NONSINUSOIDAL INPUTSFor nonsinusoidal inputs $\geq 10,000$ counts with frequency components ≥ 100 kHz, add the following % of reading to the accuracy specifications.

FUNDAMENTAL FREQUENCY	CREST FACTOR		
	1.0 TO 1.5	1.5 TO 2.0	2.0 TO 3.0
45 Hz to 20 kHz 20 Hz	0.05	0.15	0.3
20 Hz to 45 Hz and 20 kHz to 50 kHz	0.2	0.7	1.5

Operating Characteristics

MAXIMUM INPUT700V rms, 1000V peak or 2×10^7 Volts-Hertz product (whichever is less) for any range.

TEMPERATURE COEFFICIENT \pm (% of reading + Number of Counts) per °C, to 18°C and 28°C to 50°C.

FOR INPUTS	FREQUENCY IN HERTZ		
	20-20k	20k-50k	50k-100k
$\geq 10,000$ counts	0.019 + 9	0.021 + 9	0.027 + 10
$\geq 1,000$ counts	0.019 + 12	0.021 + 15	0.027 + 21

COMMON MODE REJECTION >60 dB at 50 or 60 Hz with 1 k Ω in either lead.

CURRENT

Input Characteristics

RANGE	FULL SCALE 5½ DIGITS	RESOLUTION	
		5½ DIGITS	4½ DIGITS ¹
200 mA ²	199.999 mA	1 µA	10 µA
2000 mA	1999.99 mA	10 µA	100 µA

1. 4½ digits at the fastest reading rate.
 2. The 200mA range is available for dc current only.

DC Accuracy

NORMAL (S) READING RATE±(% of reading + number of counts).

RANGE	90 DAYS 23±5°C	1 YEAR 23±5°C	2 YEARS 23±5°C
200 mA	0.04 + 40	0.05 + 40	0.08 + 40
2000 mA			
≤1A	0.04 + 4	0.05 + 4	0.08+4
>1A	0.1 + 4	0.1 + 4	0.15+4

MEDIUM AND FAST READING RATES In medium reading rate, add 2 counts (20 counts on 200 mA range) to number of counts. In fast reading rate, use 2 (4½ digit mode) counts (20 counts on 200 mA range) for number of counts.

AC Accuracy (Option –09)

NORMAL (S) READING RATE±(% of Reading + Number of Counts).

23±5°C, for sinewave inputs ≥10,000 counts¹.

FREQUENCY IN HERTZ			
	20-45	45-100	100-5K*
ONE YEAR	2.0 + 200	0.5 + 200	0.4 + 200
TWO YEAR	3.0 + 300	0.7 + 300	0.6 + 300

*Typically 20 kHz
 1. For sinewave inputs between 1,000 and 10,000 counts, add to number of counts 100 counts for frequencies 20 Hz to 5 kHz (typically 20 kHz).

MEDIUM AND FAST READING RATES.....In medium rate, add 50 counts to number of counts. In fast reading rate, for sinewave inputs ≥ 1000 (4½ digit mode) counts and frequencies > 100 Hz, the accuracy is $\pm(0.4\%$ of reading $+30$ (4½ digit mode) counts).

NONSINUSOIDAL INPUTSFor nonsinusoidal inputs $\geq 10,000$ counts with frequency components ≤ 100 kHz, add the following % of reading to the accuracy specifications

FUNDAMENTAL FREQUENCY	CREST FACTOR		
	1.0 TO 1.5	1.5 TO 2.0	2.0 TO 3.0
45 Hz to 5 kHz	0.05	0.15	0.3
20 Hz to 45 Hz	0.2	0.7	1.5

Operating Characteristics

TEMPERATURE COEFFICIENTLess than 0.1 x accuracy specification per °C to 18°C and 28°C to 50°C.

MAXIMUM INPUT2A dc or rms ac. Protected with 2A, 250V fuse accessible at front panel, and interval 3A, 600V fuse.

BURDEN VOLTAGE1V dc or rms ac typical at full scale.

RESISTANCE

Input Characteristics

RANGE	FULL SCALE 5½ DIGITS	RESOLUTION		CURRENT THROUGH UNKNOWN
		5½ DIGITS	4½ DIGITS ¹	
20 Ω^2	19.999 Ω	0.1 m Ω	1 m Ω	1 mA
200 Ω	199.999 Ω	1 m Ω	10 m Ω	1 mA
2 k Ω	1.99999 k Ω	10 m Ω	100 m Ω	1 mA
20 k Ω	19.9999 k Ω	100 m Ω	1 Ω	100 μ A
200 k Ω	199.999 k Ω	1 Ω	10 Ω	10 μ A
2000 k Ω	1999.99 k Ω	10 Ω	100 Ω	5 μ A
20 M Ω	19.9999 M Ω	100 Ω	1 k Ω	0.5 μ A

1. 4½ digits at the fastest reading rate.
2. Four-wire ohms only.

Accuracy

NORMAL (S) READING RATE±(% of Reading + Number of Counts)¹.

RANGE	24 HOURS 23±1°C	90 DAY 23±5°C	1 YEAR 23±5°C	2 YEARS 23±1°C
20Ω ³	0.007 + 30 ⁴	0.009 + 40 ⁴	0.012 + 40 ⁴	0.015 + 40 ⁴
200Ω ³	0.0040 + 3 ⁵	0.007 + 4 ⁵	0.010 + 4 ⁵	0.012 + 4 ⁵
2 kΩ	0.0025 + 2	0.005 + 3	0.008 + 3	0.010 + 3
20 kΩ	0.0025 + 2	0.005 + 3	0.008 + 3	0.010 + 3
200 kΩ	0.0025 + 2	0.006 + 3	0.010 + 3	0.012 + 3
2000 kΩ	0.023 + 3	0.025 + 3	0.027 + 3	0.030 + 3
20 MΩ	0.023 + 3	0.040 + 4	0.042 + 4	0.050 + 4

1. Within one hour of ohms zero, using offset control.
2. Relative to calibration standards.
3. Applies to 4-wire ohms only.
4. When offset control is not used the number of counts are 50, 70, 90 and 90 for 24 hours,90 day, 1 year, and 2 year respectively.
5. When offset control is not used the number of counts are 5, 7, 9 and 9 for 24 hours, 90 day, 1 year, and 2 year respectively.

MEDIUM AND FAST READING RATES.....In medium rate, add 2 counts to the number of counts for the 200Ω through 200 kΩ ranges, 3 counts for the 2000 kΩ and 20 MΩ ranges, and 20 counts for the 20Ω range. In fast reading rate, use 3 (4½ digit mode) counts for the number of counts for the 200Ω range, 20 (4½ digit mode) counts for the 20Ω range and 2 (4½ digit mode) counts for all other ranges.

Operating Characteristics

TEMPERATURE COEFFICIENTLess than 0.1 x accuracy specification per °C from 0°C to 18°C and 28°C to 50°C.

MEASUREMENT CONFIGURATION2-wire or 4-wire in all ranges except 20Ω range. Only 4-wire configuration is allowed in the 20Ω range.

OPEN CIRCUIT VOLTAGELess than 6.5V on the 20Ω through the 200 kΩ ranges. Less than 13V on the 2000 kΩ and 20 MΩ ranges.

INPUT PROTECTION.....To 300V rms.

Reading Rates

READING RATES WITH INTERNAL TRIGGER (readings per second)

RATE	POWER LINE FREQUENCY ¹		
	50 Hz	60 Hz	400 Hz
S	2.08 (.26) ²	2.5 (.31) ²	2.38 (.30) ²
M	16.7 (1.04) ²	20 (1.25) ²	19.0 (1.19) ²
F	100	100	100

1. Sensed automatically at power-up.
2. In 20 mV, 20 ohm, and 200 mA DC ranges.

AUTORANGING

The 8842A autoranges up to the highest ranges in all functions, down to the 200 mV range in the VDC and VAC functions, and down to the 200 Ω ranges in the ohms functions. To select the 20 mV dc, 20Ω, or 200 mA dc range, press the respective range button (or send the respective range command, if using the IEEE-488 option).

AUTOMATIC SETTTLING TIME DELAY

Time in milliseconds from single trigger to start of A/D conversion, Autorange off.

FUNCTION	RANGE	READING RATE			NUMBER OF COUNTS FROM FINAL VALUE ¹
		S	M	F	
VDC	20 mV	342	342	9	30
	200 mV	342	61	9	5
	2V-1000V	342	17	9	9
VAC	All	551	551	551	30 (Note 2)
MA DC	200 mA	342	342	9	9
	2000 mA	342	17	9	5
MA AC	2000 mA	551	551	551	30 (Note 2)
Ohms	20Ω	395	395	17	40
	200Ω	395	106	17	5
	2 kΩ	322	17	13	5
	20 kΩ	342	17	13	5
	200 kΩ	141	121	21	5
	2000 kΩ	141	101	81	10
	20 MΩ	1020	964	723	10

1. Difference between first reading and final value for an in-range step change coincident with trigger. For slow reading rate. 50 counts for medium rate; 10 counts for fast rate.

EXTERNAL TRIGGER TIMING CHARACTERISTICS

The following diagram shows the nominal timing for the various processes which take place between an external trigger and data sent out on the IEEE-488 interface. Delays will vary if a second trigger comes before the data handshake is complete.

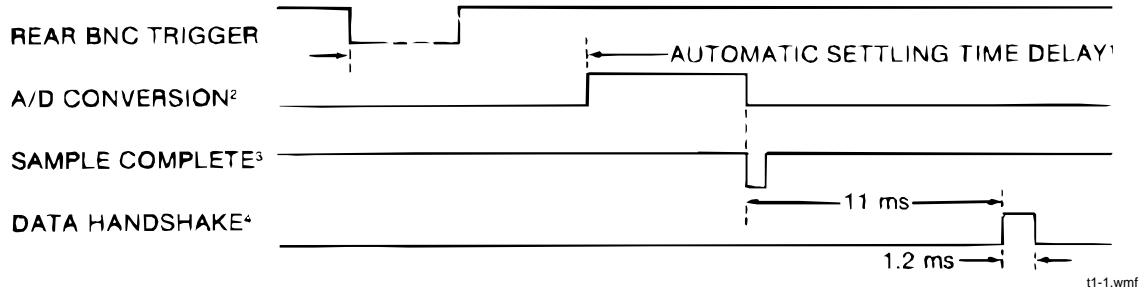

- NOTES:
1. Time for single trigger to start of A/D conversion.(See “Automatic Settling Time Delay” on previous page.) If the delay is disabled by using the T3 or T4 command, then the delay is 1 ms±150 μs. When the 8842A is triggered with an IEEE-488 command (GET or ?), the automatic settling time delay begins after the trigger command has been processed and recognized.
 2. A/D conversion time is dependent on the reading rate and power-line frequency:

RATE	A/D CONVERSION TIME (ms)		
	50 Hz	60 Hz	400 Hz
S	472 (3800)*	395 (3195)*	414 (3300)*
M	52 (960)*	45 (795)*	47 (840)*
F	7	7	7

*In 20 mV DC, 20Ω and 200 mA DC ranges.

3. Sample complete is a 2.5 μs pulse which indicates that the analog input may be changed for the next reading.
4. When talking to a fast controller.

GENERAL

- COMMON MODE VOLTAGE.....1000V dc or peak ac, or 700V rms ac from any input to earth.
- TEMPREATURE RANGE0 to 50°C operating, -40 to 70°C storage.
- HUMIDITY RANGE80% RH from 0 to 35°C, 70% to 50°C.
- WARMUP TIME1 hour to rated specifications.
- POWER100, 120, 220, or 240V ac ±10% (250V ac maximum), switch selectable at rear panel. 50, 60, or 400 Hz, automatically sensed at power-up. 20 VA maximum.
- VIBRATION.....Meets requirements of MIL-T- 28800C for Type III, Class 3, Style E equipment.
- PROTECTIONANSI C39.5 AND IEC 348, Class I.
- SIZE8.9 cm high, 21.6 cm wide, 37.1 cm deep(3.47 in high, 8.5 in wide, 14.6 in deep).
- WEIGHT.....Net, 3.4 kg (7.5 lb); shipping, 5.0 kg (11 lb).
- INCLUDED.....Line cord, test leads, Instruction/Service Manual, IEEE-488 Quick Reference Guide, (Option -05 only), and instrument performance record.
- IEEE-488 INTERFACE FUNTIONOption allows complete control and data output capability, and supports the following interface funtion subsets: SH1,AH1, T5, L4, SR1, RL1, DC1, DT1, E1, PP0, AND C0.
- ELECTROMAGNETIC COMPATIBILITY Specifications apply when used in an environment with fields strengths ≤ 1 V/m, (0.8 V/m for DC Current.) For fields strengths up to 3 V/m, multiply floor adder by 12 for VDC and Resistance and 200 for DC current. VAC and AC Current have no adders up to 3 V/m.

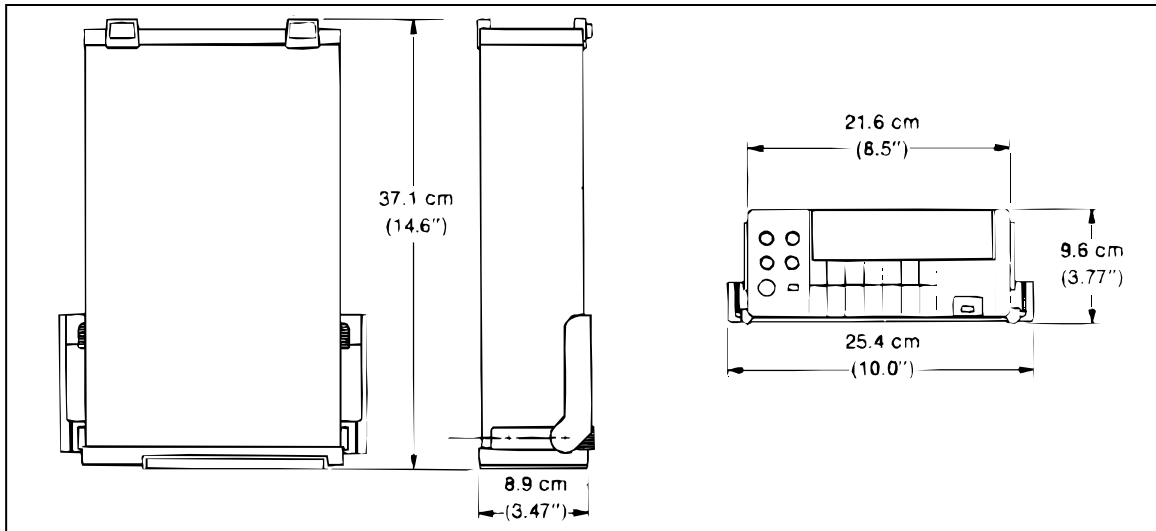

Figure 1-1. External Dimensions

f1-01.wmf

Chapter 2

Operating Instructions

	Title	Page
2-1.	INTRODUCTION	2-2
2-2.	INSTALLATION	2-2
2-3.	Installing the Power-Line Fuse	2-2
2-4.	Connecting to Line Power.....	2-2
2-5.	Adjusting the Handle.....	2-3
2-6.	Rack Mounting Kits	2-3
2-7.	OPERATING FEATURES	2-4
2-8.	Power-Up Features.....	2-4
2-9.	Front and Rear Panel Features	2-4
2-10.	Display Features.....	2-8
2-11.	Error Messages.....	2-8
2-12.	Overrange Indication.....	2-10
2-13.	Diagnostic Self-Tests	2-10
2-14.	Ranging	2-10
2-15.	AUTORANGE.....	2-10
2-16.	MANUAL RANGE.....	2-11
2-17.	Triggering.....	2-11
2-18.	CONTINUOUS TRIGGER MODE	2-11
2-19.	EXTERNAL TRIGGER MODE	2-11
2-20.	Reading Rates and Noise Rejection	2-11
2-21.	Automatic Settling Time Delay.....	2-12
2-22.	External Trigger Input (Option -05 Only).....	2-12
2-23.	Sample Complete Output (Option -05 Only)	2-12
2-24.	MAKING MEASUREMENTS	2-13
2-25.	Input Overload Protection Limits.....	2-13
2-26.	Measuring Voltage and Resistance	2-13
2-27.	Measuring Current	2-13
2-28.	Current Fuse Protection.....	2-13
2-29.	Offset Measurements	2-14
2-30.	EXTERNAL CLEANING.....	2-15

2-1. INTRODUCTION

This section provides instructions for installing and operating the 8842A. Refer to Section 4 for measurement considerations.

2-2. INSTALLATION

2-3. Installing the Power-Line Fuse

WARNING

FOR POWER-LINE VOLTAGES OF 198V TO 250V, THE POWER-LINE FUSE MUST BE REPLACED WITH A 1/8A, 250V SLO-BLO FUSE FOR FIRE PROTECTION. TO AVOID ELECTRIC SHOCK, REMOVE THE POWER CORD BEFORE REPLACING THE EXTERNAL LINE FUSE.

The 8842A has a rear-panel power-line fuse in series with the power supply. A 1/4A, 250V slow-blow fuse is installed in the factory for operation from 90V to 132V. For operation with power-line voltages of 198V to 250V, the fuse must be replaced with a 1/8A, 250V slo-blow fuse.

To replace the power-line fuse, first remove the power cord. Then turn the rear-panel fuse cover 1/4-turn counterclockwise with a screwdriver.

For power-line voltages of 198V to 250V, use only a 1/4 x 1 1/4 (6.3mm x 32mm) fuse with at least a 100A breaking capacity.

2-4. Connecting to Line Power

WARNING

TO AVOID SHOCK HAZARD, CONNECT THE INSTRUMENT POWER CORD TO A POWER RECEPTACLE WITH EARTH GROUND. TO AVOID INSTRUMENT DAMAGE, CHECK THAT THE REAR PANEL LINE VOLTAGE SELECTION SWITCHES ARE SET TO THE POWER-LINE VOLTAGE IN OUR AREA.

The 8842A can be configured to accept line power of 100, 120, 220, or 240V ac (+/-10%, 250V maximum) at 50, 60, or 400 Hz. The voltage must be selected by setting the rear panel LINE SET switches as shown in Figure 2-1. The 8842A automatically senses the power-line frequency at power-up, so that no adjustment for frequency is necessary.

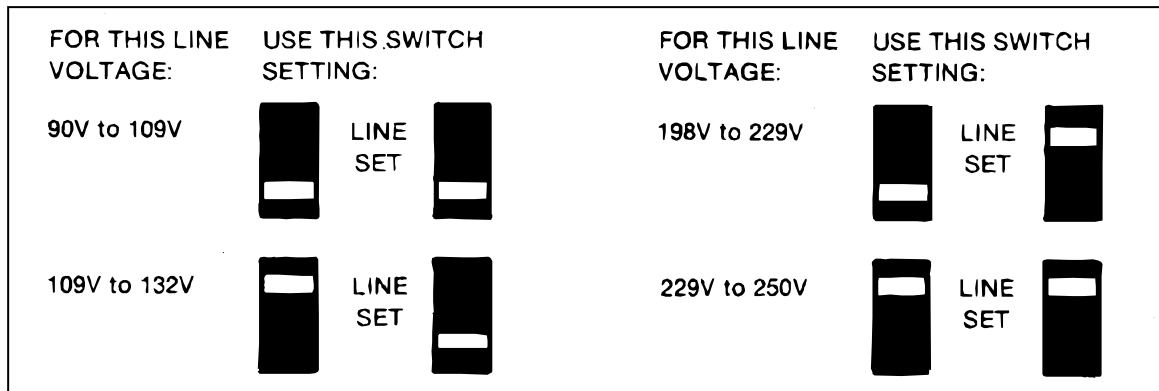

Figure 2-1. Line Voltage Selection Settings

f2-01.wmf

2-5. Adjusting the Handle

The handle provides two viewing angles for bench-top use. To adjust its position, pull the ends out to a hard stop (about 1/4 inch on each side) and rotate it to one of the four stop positions shown in Figure 2-2. To remove the handle, adjust it to the vertical stop position and pull the ends all the way out.

2-6. Rack Mounting Kits

You can mount the 8842A in a standard 19-inch rack panel using the accessory rack mounting kits shown in Figure 2-3. To install the Single Rack Mount Kit, remove the handle and handle mounting plates, and attach the rack ears with the screws provided (Figure 2-4). The Dual Rack Mount Kit is installed similarly. (Both kits include mounting instructions.)

The rear feet may be rotated 180 degrees to clear a narrow rack space.

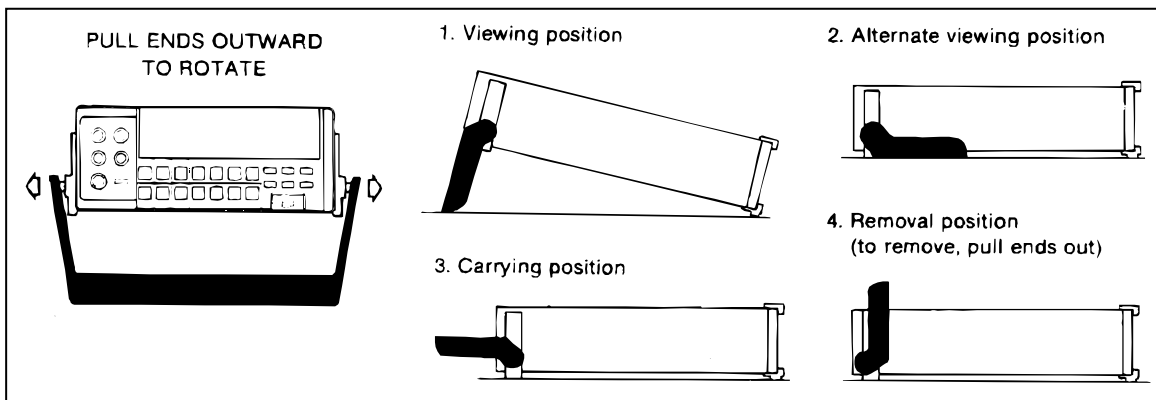

Figure 2-2. Adjusting the Handle

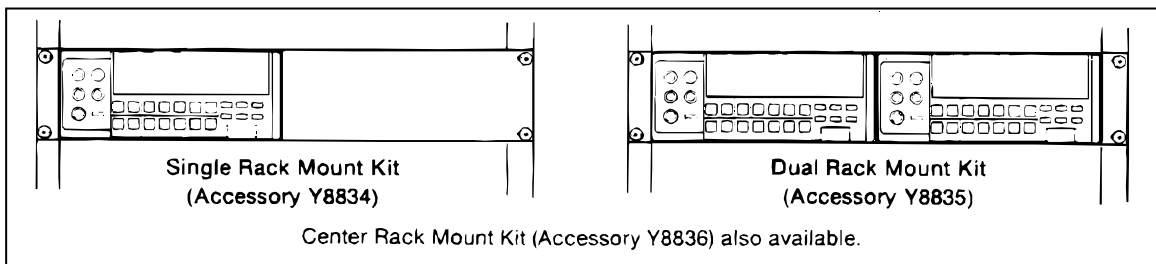

Figure 2-3. Rack-Mount Kits

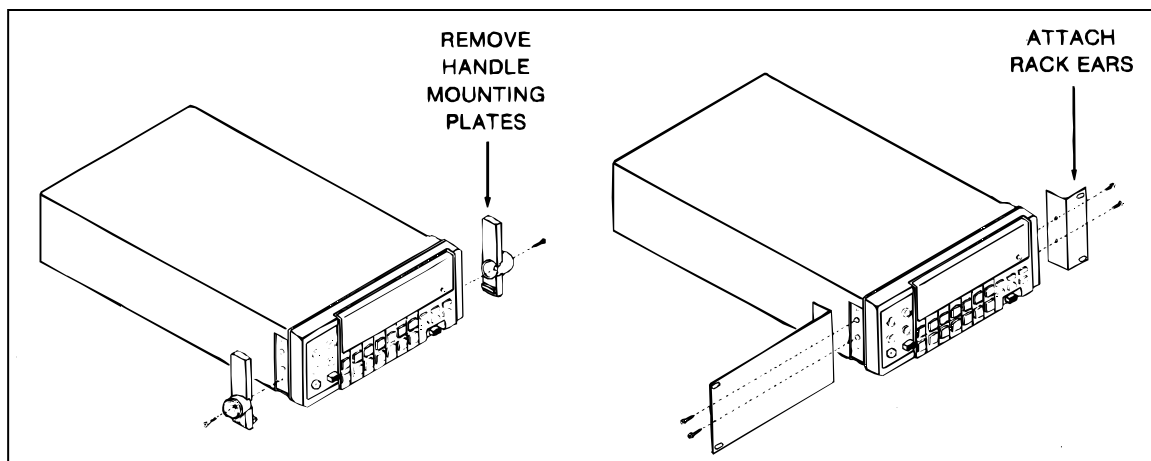

Figure 2-4. Installing the Single Rack Mount Kit

f2-04.wmf

2-7. OPERATING FEATURES

2-8. Power-Up Features

When the 8842A is turned on, all display segments light up for about 2 seconds while the instrument performs an internal self-test of its digital circuitry. The 8842A then assumes the following configuration:

- VDC function
- Autorange, starting in the 1000V range
- Slow reading rate
- Continuous, internal trigger
- OFFSET off
- Local (front panel) control

While all display segments are lit during the power-up self-test, you can freeze the display by pressing the SRQ button. All display segments will then remain lit until you press any button.

2-9. Front and Rear Panel Features

Front panel features are explained in Figure 2-5. Rear panel features are explained in Figure 2-6.

The alternate functions embossed below the front panel range buttons and the special feature buttons are enabled by the CAL ENABLE switch. These functions are for use only when calibrating the instrument. See the Maintenance section for further explanation.

CAUTION

To avoid accidentally uncalibrating the 8842A, do not press the CAL ENABLE switch unless calibrating the instrument. Never cycle power on or off while the CAL ENABLE switch is on.

Note that the VAC and mA AC functions are available only with the True RMS AC option. If this option is absent, pressing the VAC and mA AC function buttons causes the 8842A to briefly display an error message (ERROR 30).

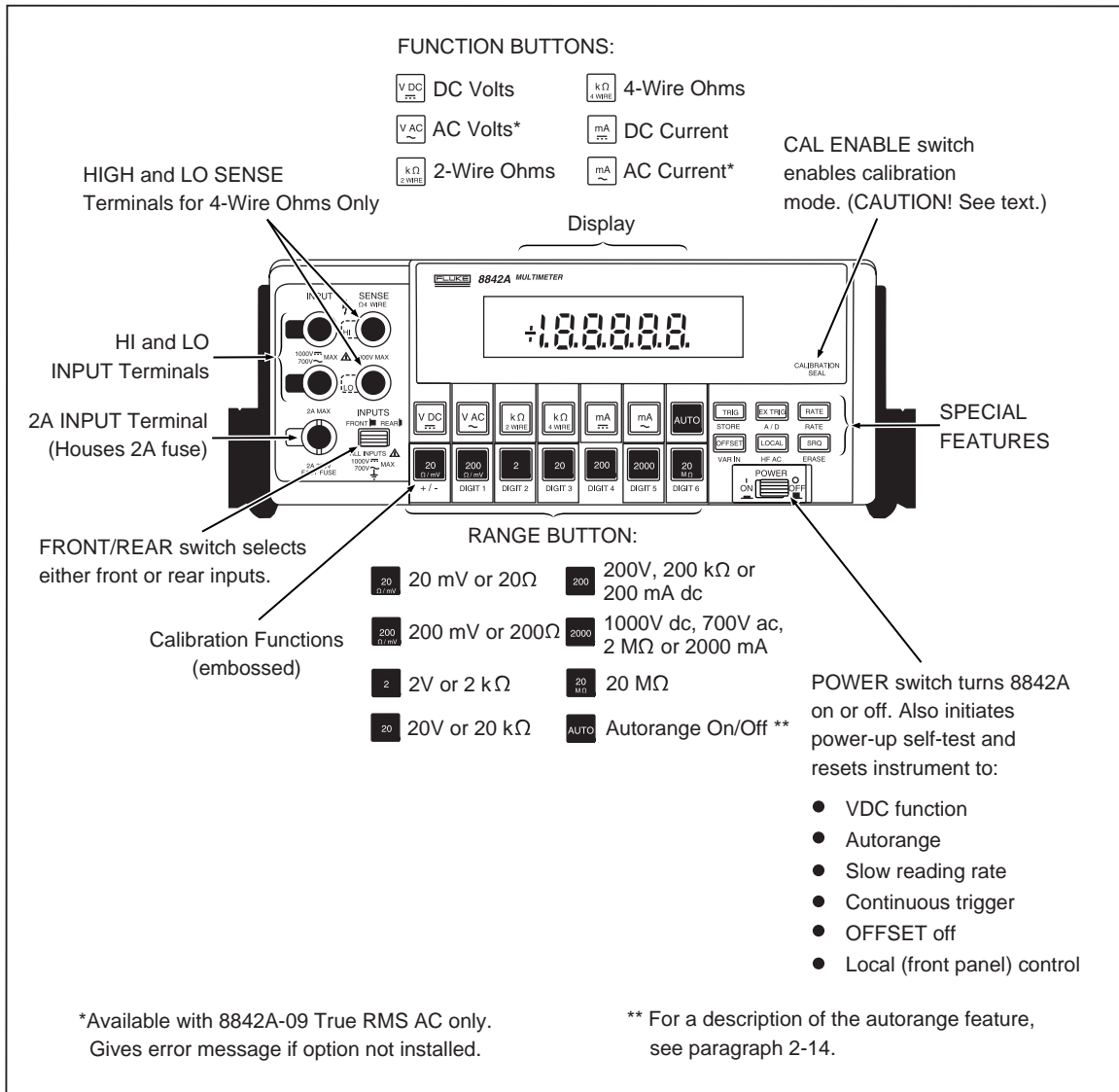

Figure 2-5. Front Panel Features

f2-05_1.wmf

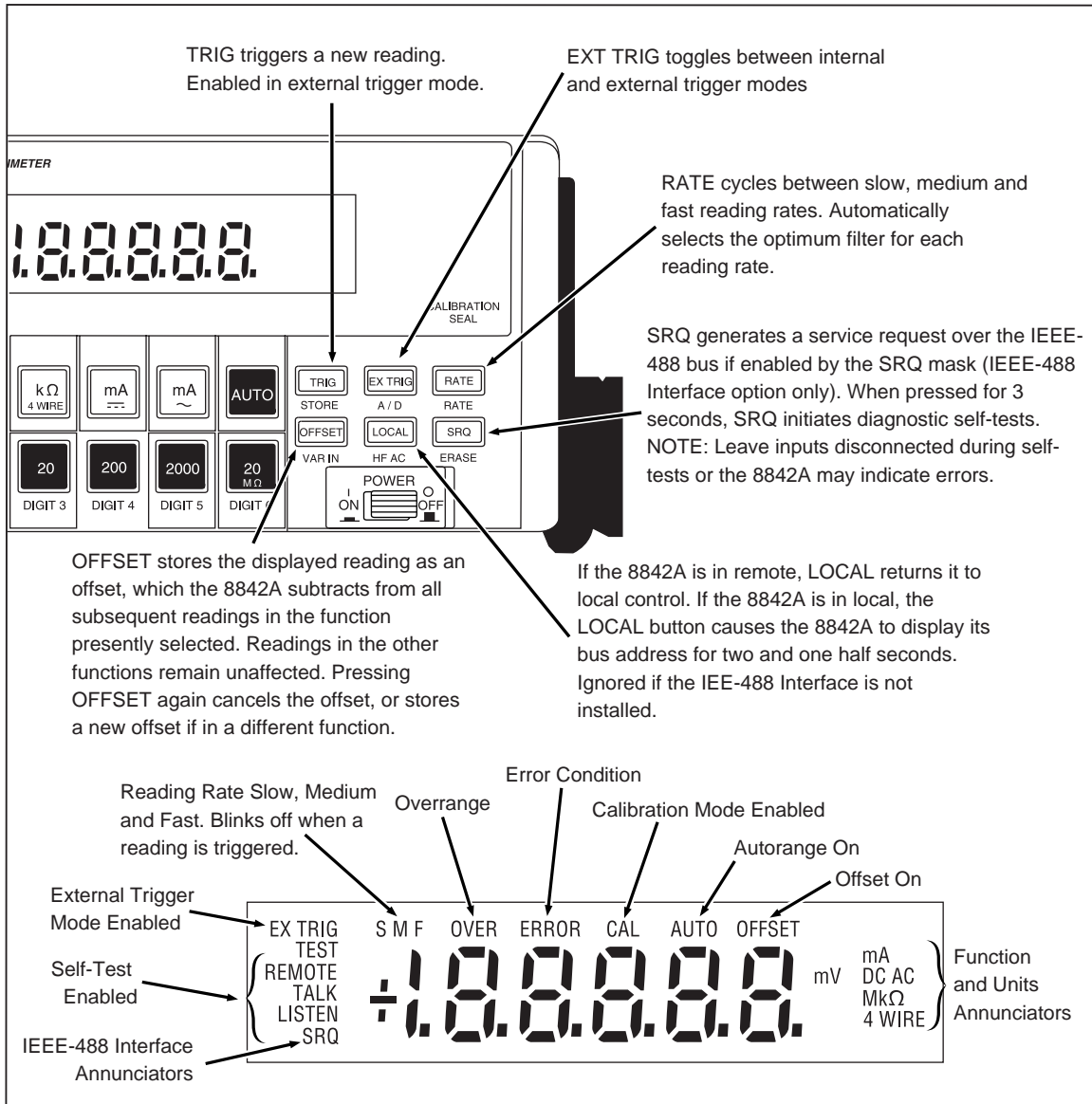
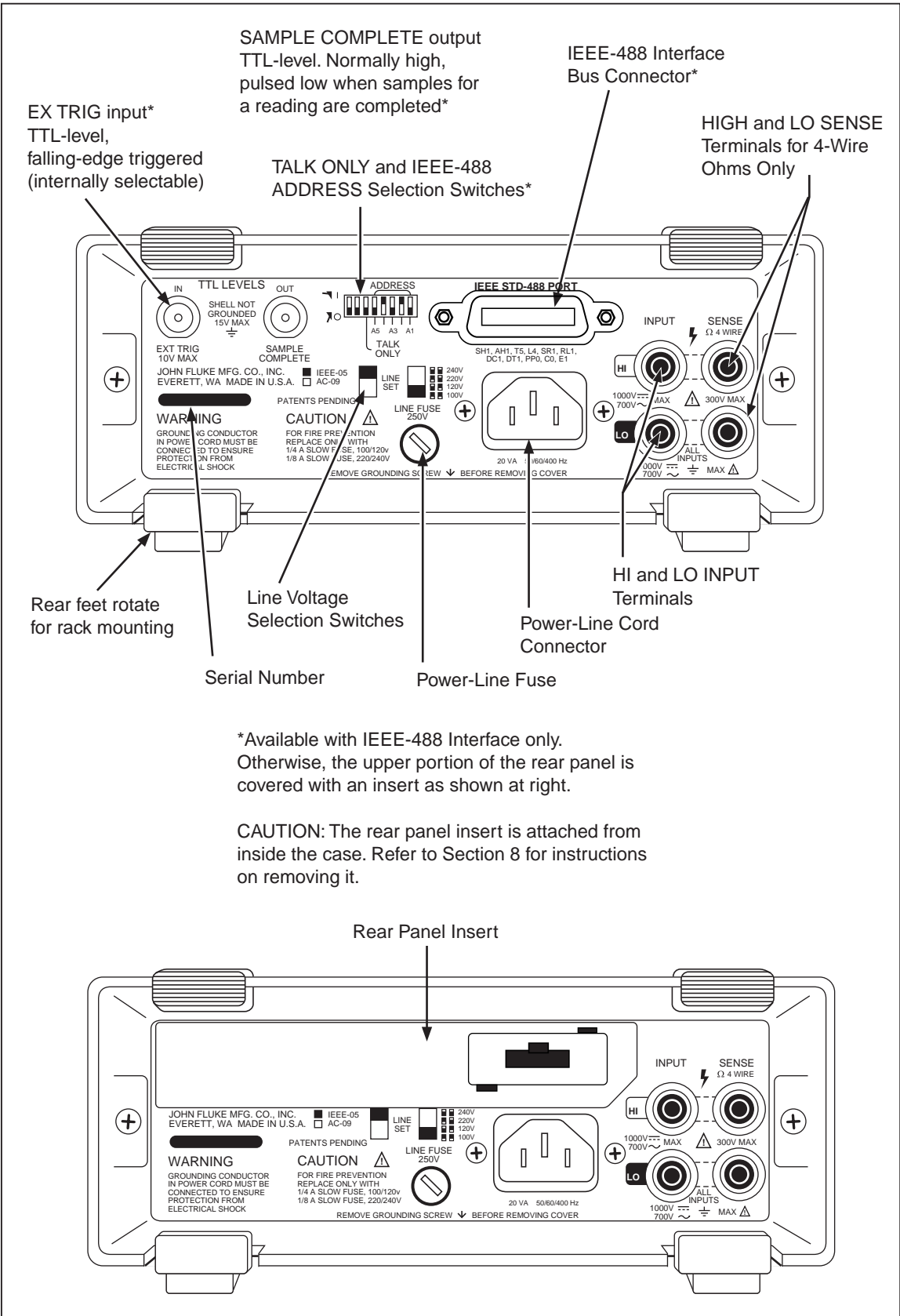

Figure 2-5. Front Panel Features (cont)

f2-05_2.wmf



*Available with IEEE-488 Interface only. Otherwise, the upper portion of the rear panel is covered with an insert as shown at right.

CAUTION: The rear panel insert is attached from inside the case. Refer to Section 8 for instructions on removing it.

Figure 2-6. Rear Panel Features

f2-06.wmf

2-10. Display Features

The 8842A features a vacuum fluorescent display with a numeric field and annunciators. The annunciators are explained in Figure 2-5.

2-11. Error Messages

If the 8842A detects an operator error or an internal failure, it displays an error message for about 2-1/2 seconds and then resumes normal operation. During this time, the front panel buttons are ignored. The error message consists of the ERROR annunciator and a two-digit error code. (See Figure 2-7.) Error codes are explained in Table 2-1.

If the FRONT/REAR switch is set to the REAR position while the mA DC or mA AC function is selected, ERROR 31 is displayed. In this case the error message is displayed until you return the switch to the FRONT position or select another function.

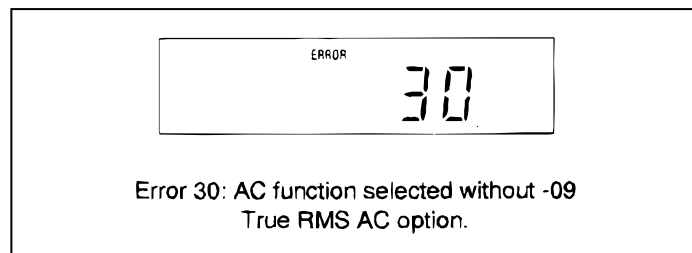

Figure 2-7. Typical Error Messages

f2-07.wmf

Table 2-1. Error Codes

ERROR CODE	MEANING	ERROR CODE	MEANING
ANALOG SELF-TEST ERRORS		OPERATION ERRORS	
1	200 VAC, Zero	30	AC funtions available only with 8842A-09 True RMS AC option.
2	700 VAC, Zero	31	mA AC or mA DC funtion selected while REAR inputs selected.
3	mA AC, Zero	32	OFFSET selected with reading unavailable for overrange.
4	mA DC, Zero	40	Computed calibration constant out of range.(Previous cal may be wrong or there may be a hardware problem.)
5	200 VDC, Zero	41	Calibration input out of acceptable range. Check that input is correct. (Previous cal may be wrong or there may be a hardware problem.)
6	1000 VDC, Zero	42	Calibration memory write error. (Probably a hardware problem.)
7	1000 VDC, Zero	50	Guard crossing error detected by In-Guard μ C.
8	20 VDC + 20M Ω	51	Calibration command not valid unless calibration mode is enabled.
9	20 VDC + 2000 k Ω	52	Command not valid at this time.
10	2 VDC + 2000 k Ω	53	Invalid calibration value in Put command. (Example: Sending a negative value during ac calibration.)
11	200 Ω , Overrange	54	Command not valid in calibration verification.
12	2 k Ω , Overrange	56	Variable inputs not allowed during A/D calibration.Use prompted value.
13	20 k Ω , Overrange	60	Device-dependent commands not valid during self-tests.
14	200 k Ω , Overrange	71	Syntax error in device-dependent command string.
15	1000 VDC + X10 T/H + 20 M Ω	72	Guard crossing error detected by out Guard μ C.
16	200 VDC + 200 k Ω	73	Guard crossing error detected at power on or CAL ENABLE switch on at power on.
17	200 VDC + 20 k Ω	77	IEEE-488 Interface self-test error.
DIGITAL SELF-TEST ERRORS			
25	In-Guard μ C Internal RAM		
26	Display RAM		
27	In-Guard μ C Internal Program Memory		
28	External Program Memory		
29	Calibration Memory		
NOTE: See the Maintenance section for a detailed description of self-tests.			

2-12. Overrange Indication

An input is overrange if it exceeds the full scale of the selected range. In most ranges, the 8842A indicates an input is overrange by lighting the OVER annunciator and showing a "1" on the display. (See Figure 2-8.) The sign, the position of the decimal point, and the other annunciators are not affected.

As a safety feature, the 8842A treats the 1000V dc and 700V ac ranges differently. In these ranges, the 8842A indicates when the input exceeds the input overload limit of 1000V dc or 700V ac, respectively, by lighting the OVER annunciator and flashing the display. Readings are still displayed.

2-13. Diagnostic Self-Tests

The 8842A features diagnostic self-tests which check both the digital and analog circuitry in the instrument. The self-tests consist of 21 analog tests followed by the in-guard program memory, calibration memory, and display self-tests. To initiate the self-tests, press the SRQ button for 3 seconds. The instrument can be stopped in any of the test configurations by pressing the SRQ button while the test number is displayed. Press any button to continue the tests.

During the test, the TEST annunciator lights, and the numeric field displays the number of each analog test as it is performed. Then all display segments light up while the instrument performs the in-guard program memory, calibration memory, and display self-tests. The 8842A then returns to the power-up configuration. The self-tests are described in greater detail in the Maintenance section.

NOTE

The inputs must be left disconnected while the self-tests are performed or the 8842A may indicate that errors are present.

If the 8842A detects an error, it displays an error message for about 2-1/2 seconds. (Error codes 01 through 29 correspond to the self-tests.) If self-test errors are displayed even when the input terminals are disconnected, there may be a hardware problem in your 8842A. In that event, refer to the Maintenance section or contact your local Fluke representative.

2-14. Ranging

Measurement ranges can be selected using either autorange (by pressing the AUTO button) or manual range (by pressing another range button). The 8842A displays explicit units in every range, so that the display may be read directly.

2-15. AUTORANGE

In autorange, the 8842A goes to a higher range when the input exceeds full scale (199999 counts), and goes to a lower range when the input falls below 9% of full scale (18000 counts). While the instrument changes range, the numeric field on the display is blanked until a new reading is completed. However, the decimal point and units annunciators always indicate what range the instrument is in.

Pressing the AUTO button when the instrument is already in autorange toggles the 8842A from autorange to manual range. This causes the instrument to remain locked in the present range.

The 8842A autoranges up to the highest ranges in all functions, down to the 200 mV range in the VDC and VAC functions, and down to the 200 Ω range in the ohms functions. To select the 20 mV dc, 20 Ω , or 200 mA dc range, press the respective range button (or send the respective range command, if using the IEEE-488 option).

2-16. MANUAL RANGE

In manual range, the 8842A remains fixed in the selected range until you select another range or press AUTO. If you select a range which is not valid for the present function, or select a function which is not valid for the present range, the 8842A selects the nearest valid range. For example, if the 8842A is in the VDC function and you press the 20 M Ω button, the 8842A selects the 1000V range.

The range buttons have no effect in the mA AC functions, since all measurements in these functions are made in the 2000 mA range.

2-17. Triggering

Triggering causes the 8842A to execute a measurement cycle and display the result. During each measurement cycle, the instrument samples the input a number of times and then averages the samples to compute a reading. The number of samples averaged for each reading depends upon the reading rate.

Each time a reading is triggered, the rate annunciator (S, M, or F) blinks off. In the fast reading rate, the F annunciator flashes so rapidly it appears to be almost constant.

How the 8842A is triggered depends on whether the continuous trigger mode or external trigger mode is selected. Pressing the EX TRIG (external trigger) button toggles the 8842A between the two modes.

2-18. CONTINUOUS TRIGGER MODE

In the continuous trigger mode, readings are triggered by a continuous, internal trigger. The rate of the trigger is set by the RATE button.

2-19. EXTERNAL TRIGGER MODE

In the external trigger mode, readings are triggered by pressing the TRIG button. If the IEEE-488 Interface option is installed, readings can also be triggered by remote commands or by using the rear panel external trigger (EXT TRIG) connector. (See the Options and Accessories section.)

In the external trigger mode, pressing any front panel button blanks the numeric field on the display until a new measurement is triggered. This ensures that all readings correspond to the instrument configuration indicated by the display annunciators. The blanking also occurs in the continuous trigger mode, but usually isn't noticed because new measurements are triggered automatically.

The TRIG button does not trigger readings in the continuous trigger mode. However, it does blank the last reading to acknowledge a button was pressed.

2-20. Reading Rates and Noise Rejection

The RATE button allows you to optimize either measurement speed or noise rejection. The 8842A uses both analog and digital filtering to allow measurements in the presence of unwanted environmental noise (especially line-related noise). However, since filtering introduces a delay in response to a change in the input signal, there is an inherent trade-off between noise rejection and measurement speed.

The instrument has three reading rates: slow (S) and medium (M), with a 5-1/2 digit display, and fast (F), with a 4-1/2 digit display. To provide optimum combinations of measurement speed and noise rejection, the RATE button allows control of both the internal trigger rate and the degree of filtering. The same degree of filtering is used in both the continuous and external trigger modes. In the 20 mV, 20 Ω , and 200 mA dc ranges, use of slow (S) filter provides maximum noise rejection.

In the continuous trigger mode, the actual number of readings displayed per second for each reading rate is determined by the line-power frequency. At power-up, the 8842A senses the line-power frequency and adjusts the analog-to-digital converter timing characteristics for optimum normal-mode noise rejection. The resulting reading rates are shown in the specifications in Section 1.

2-21. Automatic Settling Time Delay

When the external trigger mode is selected, the 8842A automatically inserts a delay after receiving a trigger signal, but before starting the first input sample. The delay is just long enough so that the reading will be correct (within a specified number of counts of the final value) even if the trigger signal occurs as the input makes a step change between zero and full scale (10,000 counts and full scale in the ac functions). The length of the delay depends on the range, function, and reading rate, as shown in the specifications in Section 1. The delay is enabled only in the external trigger mode. It can be turned off with a remote command over the IEEE-488 interface bus to accommodate special timing considerations.

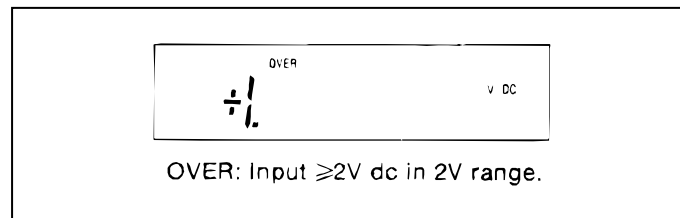

Figure 2-8. Overrange Indication

f2-08.wmf

2-22. External Trigger Input (Option -05 Only)

The rear panel EXT TRIG input is a TTL-level input which can be used to trigger measurements when the 8842A is in the external trigger mode. A measurement is triggered on the falling edge of the input. Since the EXT TRIG input is pulled high internally, it can also be controlled by a normally open switch. A measurement is triggered when the switch is closed. For special applications using the IEEE-488 Interface, the automatic setting time delay can be disabled using remote commands. (See Section 3.) Refer to Section 1 for timing details.

The polarity of the EXT TRIG input can be reversed by changing internal jumpers. Refer to the Maintenance section for instructions.

2-23. Sample Complete Output (Option -05 Only)

The SAMPLE COMPLETE output indicates when analog input sampling for a reading is completed. The output is a TTL-level signal which is pulsed low for approximately 2.5 μ s when the input-sampling portion of the A/D conversion is completed. The signal is useful for interfacing with other equipment when the 8842A is used in external trigger mode in an instrumentation system. For example, the SAMPLE COMPLETE output could be used to advance a scanner to the next channel.

2-24. MAKING MEASUREMENTS

2-25. Input Overload Protection Limits

WARNING

**TO AVOID SHOCK HAZARD AND/OR INSTRUMENT DAMAGE,
DO NOT APPLY INPUT POTENTIALS THAT EXCEED THE INPUT
OVERLOAD LIMITS SHOWN IN TABLE 2-2.**

The 8842A is protected against input overloads up to the limits shown in Table 2-2. Exceeding these limits may damage the instrument and/or pose a shock hazard.

Table 2-2. Input Overload Limits

FUNCTION	CONNECTORS	MAXIMUM INPUT
VDC	INPUT HI and LO:	1000 dc
MA DC	2A INPUT and INPUT LO:	2000mA
2 WIRE/4 WIRE kΩ	INPUT HI and LO: SENSE HI and LO:	300V rms 300V rms
VAC	INPUT HI and LO:	700V rms, 1000V peak, or 2×10^7 V-Hz (whichever is less)
MA AC	2A INPUT and INPUT LO:	2000 mA rms
All Functions	Any terminal to earth:	1000V dc or peak ac

2-26. Measuring Voltage and Resistance

To measure voltage or resistance, select the desired function and connect the test leads as shown in Figure 2-9. Resistance can be measured in either the 2-wire or 4-wire configuration.

2-27. Measuring Current

To measure current, select the desired function and connect the test leads as follows:

1. Turn off power in the circuit to be measured (Figure 2-10).
2. Break the circuit (preferably on the ground side to minimize the common mode voltage), and place the 8842A in series at that point.
3. Turn on power in the circuit, and read the display.
4. Turn off power in the circuit, and disconnect the 8842A.

2-28. Current Fuse Protection

The 2A input terminal is protected from overloads by a 2A, 250V fuse which is accessible from the front panel, and by an internal 3A, 600V fuse. If either fuse blows, the 8842A will respond as though the input were zero.

WARNING

**TO AVOID ELECTRIC SHOCK, REMOVE THE TEST LEADS
BEFORE REPLACING THE FRONT PANEL FUSE.**

To replace the front panel fuse, first remove the test leads. Then press in the lip of the 2A input terminal slightly and rotate it 1/4-turn counterclockwise. Spring tension will force the fuse and fuse holder out of the front panel. The internal 3A fuse should be replaced only by qualified service personnel.

2-29. Offset Measurements

WARNING

WHEN THE OFFSET FEATURE IS IN USE, DISPLAYED READINGS ARE RELATIVE AND MAY NOT INDICATE THE PRESENCE OF DANGEROUS POTENTIALS AT THE INPUT CONNECTORS OR TEST LEADS. USE CAUTION TO AVOID ELECTRIC SHOCK OR INSTRUMENT DAMAGE.

The OFFSET feature allows you to store a reading as a relative reference value. When the OFFSET button is pressed, the 8842A stores the present reading and displays subsequent measurements as the difference between the measured value and the stored reading. The OFFSET annunciator is lit whenever an offset is in use.

The OFFSET feature may be used in all functions. Since the display represents a numeric difference, it always has a sign, even in the resistance and ac functions.

The offset can be canceled by pressing the OFFSET button again, in which case the OFFSET annunciator disappears from the display. The offset can also be canceled by storing an offset in another function. If a reading is overrange or unavailable when the OFFSET button is pressed, the 8842A indicates ERROR 32 and does not store the offset.

If you change functions while an offset is stored, the OFFSET annunciator disappears and the offset temporarily disappears. However, when you return to the original function, the offset is restored (and the OFFSET annunciator reappears) unless a new offset was established in another function. Note that the input overload limits are not changed by the use of the offset feature. However, the display flashes if the 8842A is in the 1000V dc or 700V ac ranges and the input exceeds 1000V dc or 700V ac, respectively.

While an offset is enabled, the 8842A indicates an overrange condition if either of the following conditions occur:

- The input signal is overrange
- The calculated reading is overrange

For example, suppose the instrument is in the 20V range of the VDC function and you store an offset of +15V. The maximum positive voltage reading that can be displayed without overranging is +4.9999V, which is actually a +19.9999V input signal. The maximum negative voltage reading that can be displayed without overranging is -19.9999V, which is actually a -4.9999V input signal. You can measure a greater range of voltages by selecting a higher range.

When in autorange, the 8842A selects the range appropriate for the input signal, regardless of any stored offset. If, for example, a +10V offset is stored, and a +1V input is applied, the 8842A will autorange to the 2V range and display an overrange condition since it cannot display -9V on the 2V range. Manual range control could be used to lock the 8842A into the 20V range in this case.

Applications of the offset feature include correcting for test lead resistance in 2-wire resistance measurements, nulling offset currents or voltages, measuring voltage deviations, and matching resistors.

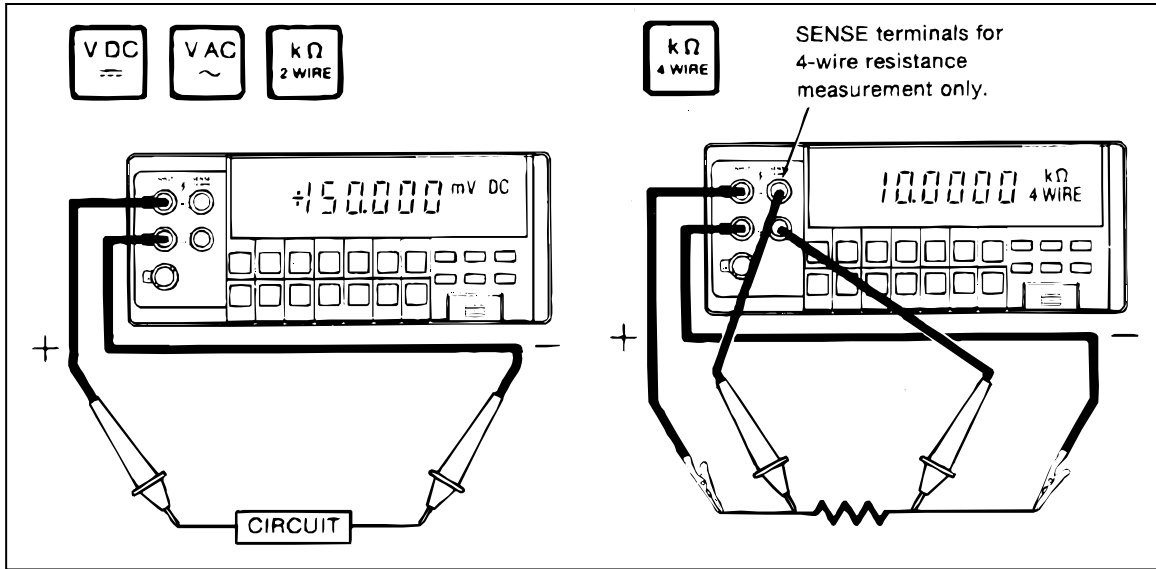

Figure 2-9. Measuring Voltage and Resistance

f2-09.wmf

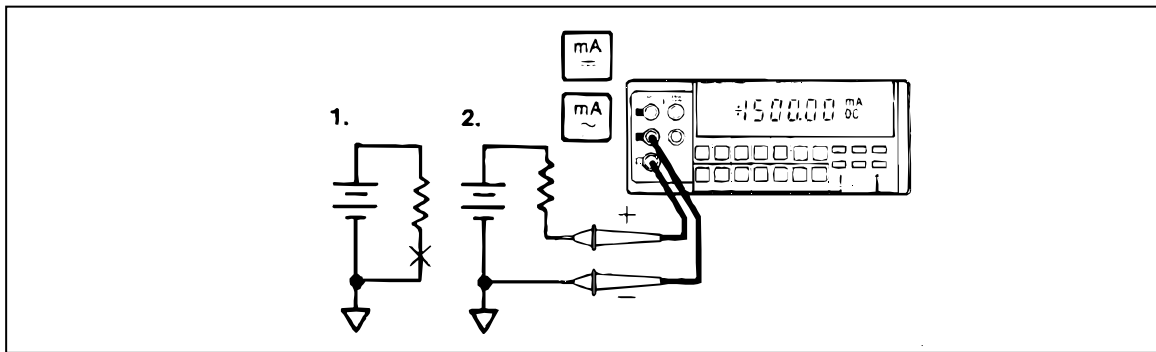

Figure 2-10. Measuring Current

f2-10.wmf

2-30. EXTERNAL CLEANING

WARNING

TO AVOID ELECTRIC SHOCK OR INSTRUMENT DAMAGE, NEVER GET WATER INSIDE THE CASE. TO AVOID INSTRUMENT DAMAGE, NEVER APPLY SOLVENTS TO THE INSTRUMENT.

Should the 8842A case require cleaning, wipe the instrument with a cloth that is lightly dampened with water or a mild detergent solution.

Chapter 3

Remote Programming

	Title	Page
3-1.	INTRODUCTION	3-3
3-2.	CAPABILITIES	3-3
3-3.	BUS SET-UP PROCEDURE	3-3
3-4.	AN OVERVIEW OF REMOTE OPERATION	3-4
3-5.	A NOTE ABOUT EXAMPLES	3-6
3-6.	DEVICE-DEPENDENT COMMAND SET	3-6
3-7.	Bn (Offset Commands)	3-9
3-8.	Cn (Calibration Commands)	3-9
3-9.	Dn (Display Commands).....	3-9
3-10.	Fn (Function Commands)	3-10
3-11.	Get Commands.....	3-10
3-12.	G0 (Get Instrument Configuration).....	3-12
3-13.	G1 (Get SRQ Mask).....	3-12
3-14.	G2 (Get Calibration Prompt).....	3-12
3-15.	G3 (Get User-Defined Message).....	3-13
3-16.	G4 (Get Calibration Status).....	3-13
3-17.	G5 (Get IAB Status).....	3-14
3-18.	G6 (Get YW Status)	3-14
3-19.	G7 (Get Error Status)	3-14
3-20.	G8 (Get Instrument Identification).....	3-15
3-21.	N (Numeric Entry Command).....	3-15
3-22.	Put Commands	3-15
3-23.	P0 (Put Instrument Configuration).....	3-15
3-24.	P1 (Put SRQ Mask).....	3-16
3-25.	P2 (Put Calibration Value).....	3-16
3-26.	P3 (Put User-Defined Message).....	3-17
3-27.	Rn (Range Commands)	3-17
3-28.	Sn (Reading Rate Commands)	3-17
3-29.	Tn (Trigger Mode Commands)	3-18
3-30.	Wn (Terminator Commands)	3-19
3-31.	X0 (Clear Error Register Command)	3-19
3-32.	Yn (Suffix Commands)	3-19
3-33.	Z0 (Self-Test Command)	3-19
3-34.	(Device-Clear Command)	3-20

3-35.	? (Single-Trigger Command)	3-20
3-36.	INPUT SYNTAX	3-20
3-37.	Definitions.....	3-21
3-38.	Input Processing.....	3-21
3-39.	Syntax Rules	3-23
3-40.	OUTPUT DATA	3-24
3-41.	Loading Output Data.....	3-24
3-42.	Types of Output Data.....	3-25
3-43.	Numeric Data and Error Messages.....	3-25
3-44.	MEASUREMENT DATA	3-25
3-45.	OVERRANGE INDICATION	3-26
3-46.	ERROR MESSAGES	3-26
3-47.	Status Data	3-26
3-48.	Output Priority	3-26
3-49.	SERVICE REQUESTS	3-27
3-50.	The Serial Poll Register	3-27
3-51.	The SRQ Mask.....	3-28
3-52.	INTERFACE MESSAGES	3-29
3-53.	Address Messages	3-29
3-54.	Universal Commands	3-29
3-55.	Addressed Commands.....	3-30
3-56.	TALK-ONLY MODE	3-30
3-57.	REMOTE CALIBRATION.....	3-31
3-58.	TIMING CONSIDERATIONS	3-31
3-59.	IMMEDIATE MODE COMMANDS	3-31
3-60.	EXAMPLE PROGRAMS	3-32

NOTE

This section contains programming instructions for use with the IEEE-488 Interface (Option -05). For installation instructions, refer to the Options and Accessories section.

3-1. INTRODUCTION

The IEEE-488 Interface turns the 8842A into a fully programmable instrument for use with the IEEE Standard 488-1978 interface bus (IEEE-488 bus). With the IEEE-488 Interface, the 8842A can become part of an automated instrumentation system. The 8842A can be under complete, interactive control from a remote bus controller; or it can be set to the talk-only mode, connected to a data logger or printer, and dedicated to a single task.

This manual assumes you know the basics of the IEEE-488 interface bus. For an introduction to the bus, request Fluke Application Bulletin AB-36, "IEEE Standard 488-1978 Digital Interface for Programmable Instrumentation."

3-2. CAPABILITIES

The IEEE-488 Interface provides remote control of all front panel controls except for the POWER, CAL ENABLE, and FRONT/REAR switches. Other features include:

- A simple and predictable command set
- Fast measurement throughput
- Full talk/listen capability, including talk-only operation
- Full serial poll capability, with bit-maskable SRQ
- Full remote/local capability, including local lockout
- EXTERNAL TRIGGER and SAMPLE COMPLETE connectors
- Remote calibration
- Programmable trigger sources, including two bus triggers
- Informative output suffix (suppressible)
- Selectable output terminators

The 8842A supports the following interface function subsets: SH1, AH1, T5, L4, SR1, RL1, DC1, DT1, E1, PP0, and C0.

3-3. BUS SET-UP PROCEDURE

To set up the 8842A on the IEEE-488 bus, proceed as follows:

1. Turn the 8842A POWER switch OFF and set the 8842A IEEE-488 address using the rear panel IEEE-488 address switches shown in Figure 3-1.
2. With the 8842A POWER switch OFF, plug the IEEE-488 cable into the 8842A rear panel IEEE-488 connector.
3. Switch on the 8842A.

ADDRESS ONLY	A5	A4	A3	A2	A1	ADDRESS ONLY	A5	A4	A3	A2	A1	ADDRESS ONLY	A5	A4	A3	A2	A1			
00	0	0	0	0	0	0	11	0	0	1	0	1	1	22	0	1	0	1	1	0
01	0	0	0	0	0	1	12	0	0	1	1	0	0	23	0	1	0	1	1	1
02	0	0	0	0	1	0	13	0	0	1	1	0	1	24	0	1	1	0	0	0
03	0	0	0	0	1	1	14	0	0	1	1	1	0	25	0	1	1	0	0	1
04	0	0	0	1	0	0	15	0	0	1	1	1	1	26	0	1	1	0	1	0
05	0	0	0	1	0	1	16	0	1	0	0	0	0	27	0	1	1	0	1	1
06	0	0	0	1	1	0	17	0	1	0	0	0	1	28	0	1	1	1	0	0
07	0	0	0	1	1	1	18	0	1	0	0	1	0	29	0	1	1	1	0	1
08	0	0	1	0	0	0	19	0	1	0	0	1	1	30	0	1	1	1	1	0
09	0	0	1	0	0	1	20	0	1	0	1	0	0	31	Not allowed					
10	0	0	1	0	1	0	21	0	1	0	1	0	1	TALK ONLY	1	X	X	X	X	X
																X = setting does not matter				

f3-01.wmf

Figure 3-1. IEEE-488 Address Selection

Whenever the 8842A is in the local state, the IEEE-488 address can be displayed on the front panel by pressing the LOCAL button.

3-4. AN OVERVIEW OF REMOTE OPERATION

An overview of remote operation is presented in the block diagram in Figure 3-2. Each block represents a register, buffer, etc., contained in the 8842A. The status registers in the center column indicate the instrument's status, including its function, range, reading rate, etc. The input buffer receives data from the IEEE-488 bus. The output buffer receives data from the blocks to its left, and sends data on to the IEEE-488 bus.

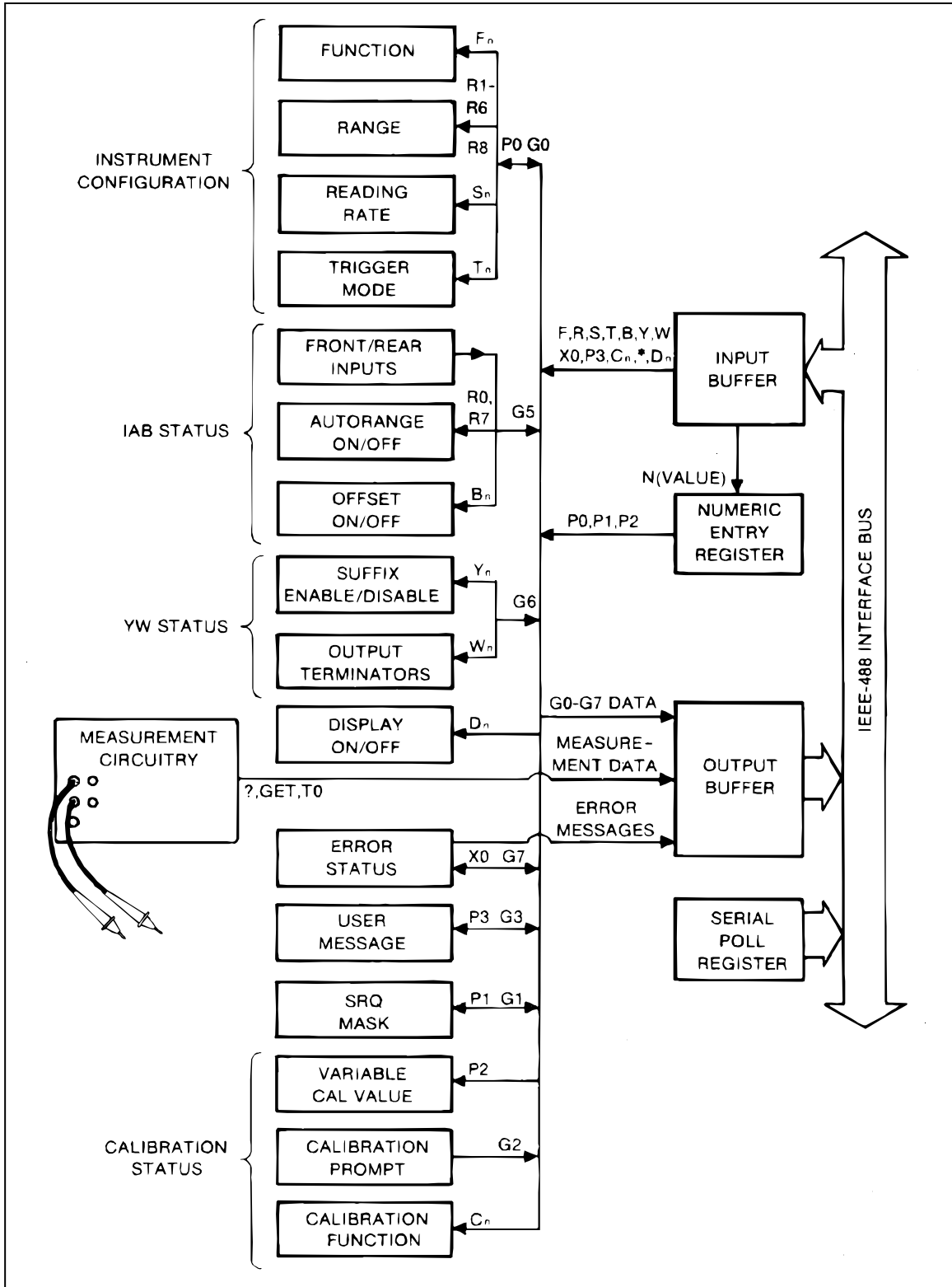

Figure 3-2. Remote Operation Block Diagram

f3-02.wmf

Information is transferred between blocks by device-dependent commands. Each command is shown next to an arrowhead which indicates the resulting information transfer. For example, Put command P0 takes a number from the input buffer and stores it in the primary status registers. Likewise, Get command G0 gets the content of the primary status registers and copies it into the output buffer.

3-5. A NOTE ABOUT EXAMPLES

In the examples in this manual, device-dependent commands are shown enclosed within quotation marks, as they would be entered in Fluke BASIC. For clarity, the commands are also separated by spaces. However, the spaces are not necessary and may be omitted.

<i>Example</i>	<i>Explanation</i>
"* F3 R1 S1 T2"	This example is equivalent to "*F3R1S1T2" or "*,F3,R1,S1,T2".

Using the Fluke 1722A Instrument Controller, these commands might be written into a BASIC program as shown in Figure 3-3. Examples using other controllers are given at the end of this section.

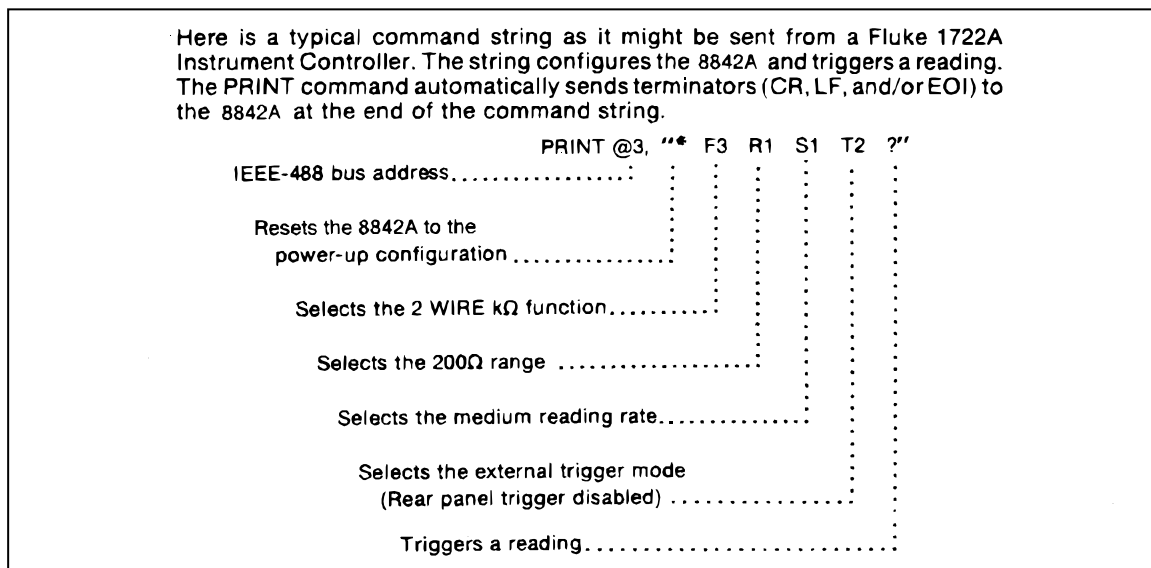

Figure 3-3. Typical Command String

f3-03.wmf

Examples of 8842A output data show the terminators CR and LF. The terminator EOI is not shown because it is a uniline message. However, the terminators CR, LF, and EOI are all selectable using the Write commands.

For reference, the ASCII and IEEE Std 488-1978 bus codes are shown at the back of this section.

3-6. DEVICE-DEPENDENT COMMAND SET

Device-dependent commands are the heart of 8842A remote control. They tell the 8842A how and when to make measurements, when to put data on the bus, when to make service requests, etc. Commands which correspond directly to the front panel controls or display are shown in Figure 3-4. The complete set of device-dependent commands is listed in Figure 3-5. The commands may be entered using either upper- or lower-case letters. See Table 6-15 for conditions under which certain commands are not valid.

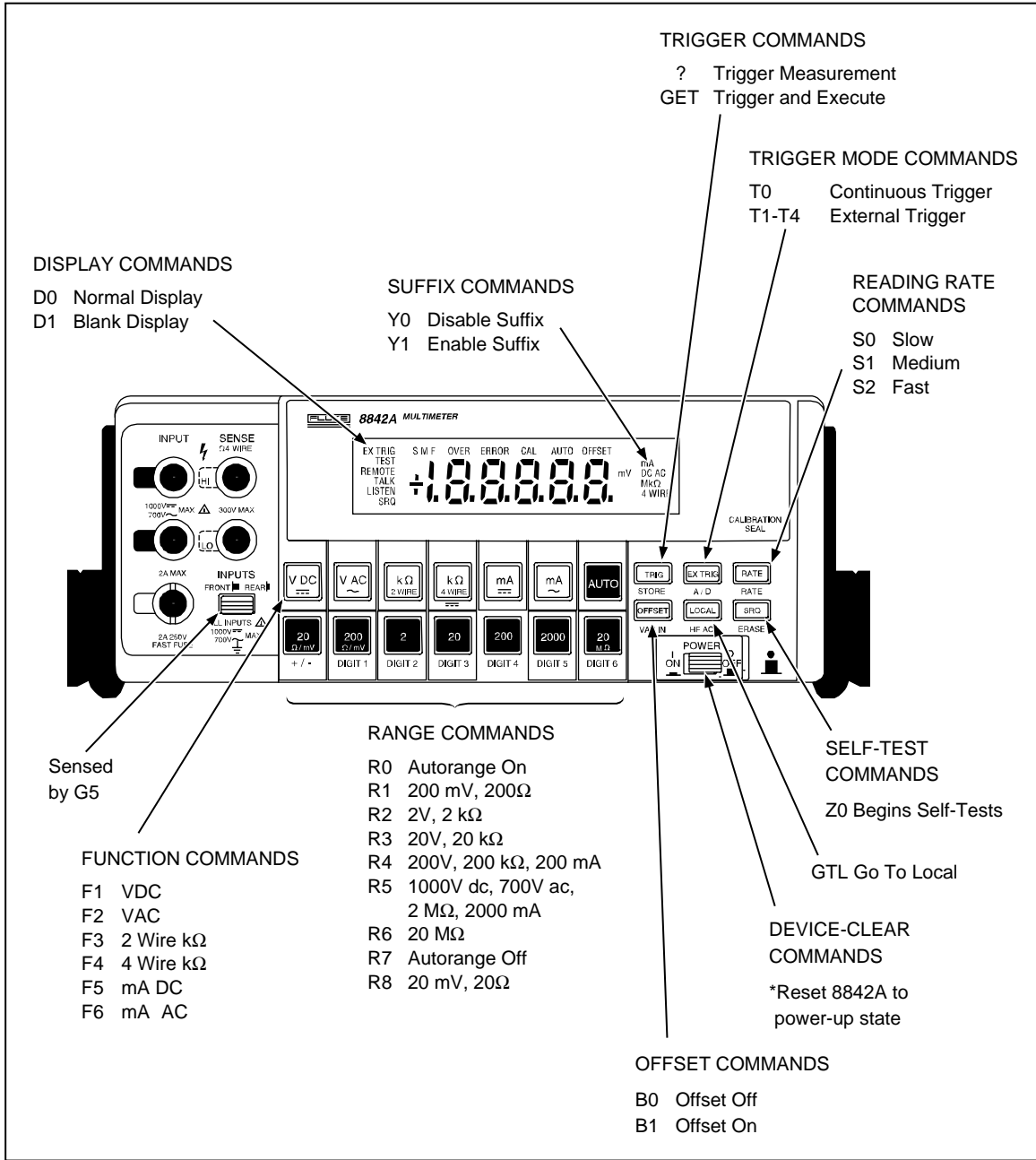

Figure 3-4. Commands Which Correspond to the Front Panel

f3-04.wmf

FUNCTION COMMANDS				TERMINATOR COMMANDS			
F1	VDC (Default)			W0	Enable CR LF EOI (Default)		
F2	VAC			W1	Enable CR LF Only		
F3	2 WIRE k Ω			W2	Enable CR EOI Only		
F4	4 WIRE k Ω			W3	Enable CR Only		
F5	MA DC			W4	Enable LF EOI Only		
F6	MA AC			W5	Enable LF Only		
RANGE COMMANDS				W7	Disable All Output Terminators		
R0	Autorange			CLEAR COMMANDS			
R2	2V, 2 k Ω			*	Device Clear (Resets 8842A to default conditions)		
R3	20V, 20 k Ω			X0	Clear Error Register		
R5	1000V dc, 700V ac, 2 M Ω , 2000 mA			SINGLE-TRIGGER COMMAND			
R6	20 m Ω			?	Trigger Measurement		
R8	20mV, 20 Ω			GET COMMANDS			
READING RATE COMMANDS				G0	Get Instrument Configuration (F,R,S, and T)		
S0	Slow (Default)			G1	Get SRQ Mask		
S1	Medium			G2	Get Calibration Input Prompt		
S2	Fast			G3	Get User-Defined Message		
TRIGGER MODE COMMANDS				G4	Get Calibration Status		
COMMAND	TRIGGER MODE	REAR PANEL TRIGGER	SETTLING DELAY	G5	Get IAB Status (input F/R, Autorange On/Off, Offset On/Off)		
TO (Default)	Internal	Disabled	-	G6	Get YW Status (Suffix Enabled/Disabled, Terminator Selection)		
T1	External	Enabled	On	G7	Get Error Status		
T2	External	Disabled	On	G8	Get Instrument Identification		
T3	External	Enabled	Off	Note:	G2 valid only in calibration mode.		
T4	External	Disabled	Off	PUT COMMANDS			
Note: Delay is enabled by entering EX TRIG mode while in local.				P0	Put Instrument Configuration (F,R,S, and T)		
OFFSET COMMANDS				P1	Put SRQ Mask		
B0				P2	Put Variable Calibration Value		
B1				P3	Put User-Defined Message		
DISPLAY COMMANDS				Note:	P2 and P3 valid only in calibration mode.		
D0	Offset Off (Default)			PUT COMMAND FORMAT			
D1	Offset On			N	<value> P0		
SUFFIX COMMANDS				N	<value> P1		
Y0	Normal Display (Default)			N	<value> P2		
Y1	Blank Display			P3	< 16 ASCII characters>		

Figure 3-5. Device-Dependent Command Set

Device-dependent commands are device-dependent messages. For the 8842A to receive them, they must be sent over the IEEE-488 bus when the 8842A is in remote and has been addressed as a listener.

The following paragraphs describe the device-dependent commands in alphabetical order. Special characters (* and ?) are described last.

3-7. Bn (Offset Commands)

The Offset commands duplicate the function of the front panel OFFSET button. When the 8842A receives the B1 command, the 8842A stores the present reading as an offset for the present function. The B0 command cancels the offset. As with front panel operation, only one offset is allowed at a time.

The offset status (not the offset value) can be read using the G5 command. The 8842A defaults to B0 on both power-up and on any device-clear command (*, DCL, or SDC).

3-8. Cn (Calibration Commands)

CAUTION

The command string "C3 C0" erases the entire calibration memory. A complete calibration must then be performed.

The Calibration commands allow the 8842A to be calibrated under remote control. Commands C0, C1, and C2 duplicate the front panel calibration functions STORE, A/D, and HF AC, respectively. For a complete description of remote calibration, see the Maintenance section of this manual.

For the 8842A to accept these commands, the 8842A must be in the calibration mode (enabled by pressing the front panel CAL ENABLE switch). Otherwise, the commands generate an error message.

3-9. Dn (Display Commands)

The Display commands allow the user to blank the numeric field in the 8842A front panel display. The D0 command causes the display to operate normally, and is the default on power-up and upon any device-clear command (*, DCL, or SDC).

The D1 command blanks the numeric field in the display. The annunciators remain active, and all of the annunciators still flash if the input exceeds 1000V dc or 700V ac in the respective ranges. The D1 command is used for best performance when high IEEE-488 Interface Data rates are required.

3-10. Fn (Function Commands)

The function commands duplicate the front panel function buttons. The 8842A defaults to F1 on power-up and on any device-clear command (*, DCL, or SDC). If F0 is sent to the 8842A, it is internally converted to F1. The function setting can be read using the G0 command.

As with the front panel commands, selecting F6 automatically selects the 2000 mA range (R5). If the instrument is in range R8, commanding F5 automatically selects the 200 mA range (R4). If the instrument is in R1 through R6, commanding F5 automatically selects the 2000 mA range (R5). If the 8842A is in a resistance function (F3 or F4) and in R6, selecting any other function automatically selects R5. If the 8842A is in range R8 and F2 or F3 is commanded, range R1 is selected.

<i>Example</i>	<i>Explanation</i>
"F3"	Selects 2 WIRE kΩ function; it does not affect any other settings.
"* F6"	Selects mA AC function and 2000 mA range. Resets all other settings to default.

3-11. Get Commands

The Get commands "get" information from the 8842A for the controller. Each Get command loads the output buffer with an output string in the format shown in Figure 3-6. Status data (the output from Get commands G0, G1, G3, G4, G5, G6, G7 and G8) is interpreted as shown in Table 3-1. The Get commands should not be confused with the interface message GET (Group Execute Trigger).

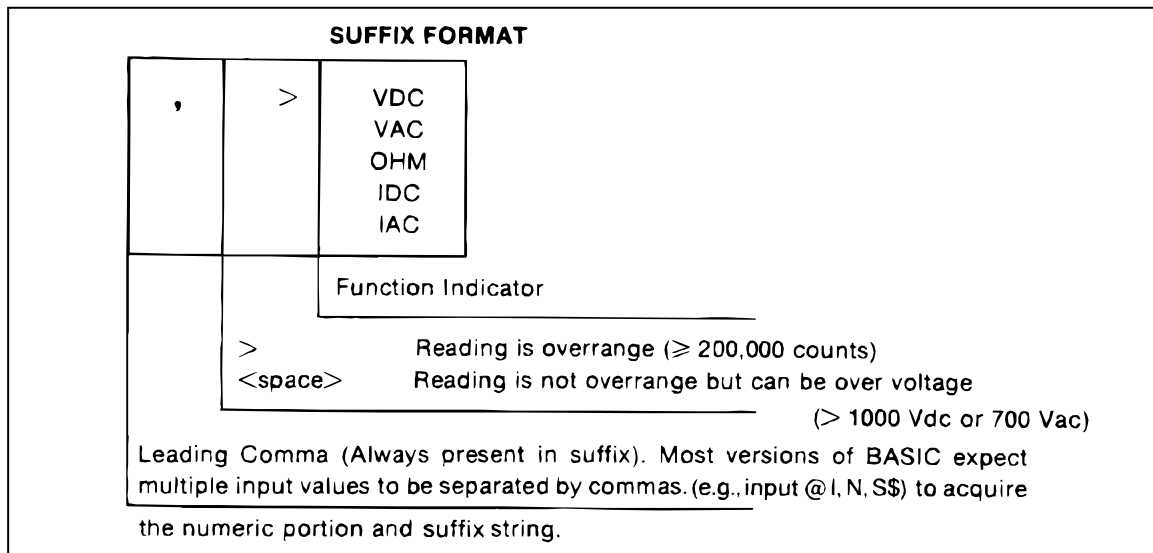

Figure 3-6. Output Data Format

f3-06.wmf

Table 3-1. Status Data

COMMAND	OUTPUT STRING	MEANING
G0	Frst	F = 1 – 6 as in Funtion commands (Fn) 9 for Self-Test r = 1 – 6 and 8 in Range commands (Rn) s = 0 – 2 as in Reading Rate commands (Sn) t = 0 – 4 as in Trigger Mode commands (Tn)
G1	nn	nn = 00 for SRQ disabled (default) 01 for SRQ on overrange 04 for SRQ on front panel SRQ 08 for SRQ on cal step complete 16 for SRQ on data available 32 for SRQ on any error Note: SRQ mask values may be added for combinations. Example: 33 for SRQ on overrange or any error.
G3	aaaaaaaaaaaaaaaa	16 user-defined ASCII characters
G4	10vm	V = 0 Not in cal verification 1 Cal verification m = 0 Not in calibration mode 1 A/D calibration 2 Offset and gain calibration 4 HF AC calibration
G5	1iab	l = 0 FRONT inputs selected 1 REAR inputs selected a = 0 Autorange on 1 Autorange off (manual range) b = 0 OFFSET off 1 OFFSET on
G6	10yw	Y = 0 output suffix disabled 1 output suffix enabled w = 0 – 7 as in Terminator commands (Wn)
G7	10nn	nn represents error code (See Table 2-1)
G8	FLUKE, mmmmm, 0, Vn.n	Mmmmm = 8842A Vn.n = IEEE-488 Interface software version number

The output data from some Get commands starts with a leading 1 or 10. This prevents the controller from suppressing leading zeroes and gives a uniform four-character length to all instrument configuration data (the data from Get commands G0, G4, G5, G6, and G7).

The Get commands are described further in the following paragraphs. For more information about output data, see paragraph 3-39.

3-12. **G0 (Get Instrument Configuration)**

The G0 command copies the 8842A function, range, reading rate, and trigger mode into the output buffer in the format shown in Figure 3-6. The four digits returned represent the arguments for the equivalent F, R, S, and T commands, as shown in Table 3-1. An example output string follows.

<i>Example</i>	<i>Explanation</i>
3410 CR LF	3: F3 (2 WIRE k Ω function) 4: R4 (200 k Ω range) 1: S1 (Medium reading rate) 0: T0 (Continuous trigger)

The second digit, which can vary from 1 to 6, indicates what measurement range the 8842A is in regardless of whether the 8842A is in autorange or manual range.

The output string from a G0 command is acceptable as an argument for an "N" command. This allows you to configure the 8842A from the front panel and then record the configuration over the bus for future use with a P0 command. However, 9mmm (meaning self-test) can not be used with the P0 command.

3-13. **G1 (Get SRQ Mask)**

The G1 command copies the present SRQ mask into the output buffer in the format shown in Figure 3-6. The SRQ mask values are explained in Table 3-1. An example output string follows. For more about the SRQ mask, see paragraph 3-47.

<i>Example</i>	<i>Explanation</i>
33 CR LF	Enable SRQ on any error or overrange

3-14. **G2 (Get Calibration Prompt)**

The G2 command is used when calibrating the 8842A under remote control. The command loads the output buffer with a calibration prompt that represents the input expected at the analog inputs. The calibration prompt is formatted as a signed decimal with exponent, as shown in Figure 3-6. The suffix may be enabled with the Y1 command. Example output strings follow.

<i>Examples</i>	<i>Explanation</i>
+1.00000E+0 CR LF	Calibration prompt
+190.000E-3 CR LF	Calibration prompt
+1.90000E+0, VDC CR LF	Calibration prompt (Suffix enabled)

If an error has occurred, the G2 command loads the output buffer with an error message instead of the prompt. (See paragraph 3-39.)

The G2 command is valid only when the calibration mode is enabled by pressing the front panel CAL ENABLE switch. If the 8842A is not in the calibration mode, the G2 command generates an error message.

3-15. G3 (Get User-Defined Message)

The G3 command loads the output buffer with the user-defined message stored in calibration memory during the calibration procedure. The message consists of 16 ASCII characters, as shown in Figure 3-6.

The message is stored in calibration memory during calibration using the P3 command. If fewer than 16 characters have been stored, the remaining characters returned are spaces. If no message has ever been stored, a string of 16 null characters (hex 00) will be returned. Some example output strings follow.

<i>Example</i>	<i>Explanation</i>
FL8842A.12-17-83 CR LF	Identifies instrument and gives cal date.
01-25-84 CR LF	Gives cal date. The last eight characters are blank.

3-16. G4 (Get Calibration Status)

The G4 command is used when calibrating the 8842A under remote control. The command loads the output buffer with the instrument's calibration status in the format shown in Figure 3-6. The status is represented by a four-digit integer which is interpreted in Table 3-1.

The first two digits are always 1 and 0. The third digit indicates whether or not the calibration verification mode is enabled. (This mode is enabled only when the calibration mode is enabled.) The fourth digit indicates whether or not the calibration mode is enabled, and if so, which part of the calibration procedure the 8842A is in. Example output strings follow.

<i>Example</i>	<i>Explanation</i>
1000 CR LF	1: Leading 1 0: Leading 0 0: Not in cal verification 0: Cal mode disabled
1001 CR LF	1: Leading 1 0: Leading 0 0: Not in cal verification 1: Cal mode enabled; A/D cal selected

3-17. G5 (Get IAB Status)

The G5 command loads the output buffer with the IAB status in the format shown in Figure 3-6. As Table 3-1 explains, the IAB status is a four-character string which indicates the status of the FRONT/REAR switch (front or rear analog inputs selected), the autorange feature (autorange on or off), and the OFFSET feature (OFFSET on or off). The first digit is always 1. An example output string follows.

<i>Example</i>	<i>Explanation</i>
1011 CR LF	1: Leading 1 0: FRONT inputs 1: Autorange off 1: OFFSET feature on

It is useful to know whether autorange is on or off because this information is not available from the G0 command. For example, the G0 command could indicate that the 8842A was in the 200 mV range, but it would not indicate whether the 8842A was in autorange or manual range.

3-18. G6 (Get YW Status)

The G6 command loads the output buffer with the YW status in the format shown in Figure 3-6. The YW status is a four-character string which indicates which terminators are selected and whether the output suffix is enabled or disabled, as shown in Table 3-1. The first two digits are always 1 and 0. An example output string follows.

<i>Example</i>	<i>Explanation</i>
1015 LF CR	1: Leading 1 0: Leading 0 1: Y1 (enable output suffix) 5: W5 (enable LF only)

3-19. G7 (Get Error Status)

The G7 command copies the error status register into the output buffer in the format shown in Figure 3-6. The first two digits are always 1 and 0. The second two digits represent the appropriate error code, if an error has occurred. (Error codes are listed in Table 2-1, Section 2). If an error has not occurred, the second two digits are 00. An example output string follows.

<i>Example</i>	<i>Explanation</i>
1071 CR LF	1: Leading 1 0: Leading 0 71: Syntax error in device-dependent command string

The G7 command gives the error status as it exists when the command is executed at its position in the input string. The G7 command does not clear the error status register. For more information about error messages, see paragraph 3-40.

3-20. G8 (Get Instrument Identification)

The G8 command copies the 8842A instrument identification into the output buffer in the format shown in Figure 3-6. The identification is represented by four comma separated fields that are interpreted in Table 3-1.

The first field indicates the manufacturer, the second indicates the instrument model number, the third is always zero, and the fourth indicates the version number of the IEEE-488 interface software.

<i>Example</i>	<i>Explanation</i>
FLUKE,8842A,0,V4.0 CR LF	This instrument is a Fluke 8842A with IEEE-488 interface software version 4.0.

3-21. N (Numeric Entry Command)

<i>Format</i>	<i>Explanation</i>
N<numeric entry>	Where <numeric entry> is one of the following: <signed integer> <signed real number without exponent> <signed real number>E<signed exponent>

<i>Example</i>	<i>Explanation</i>
"N12001"	Enters the five-digit integer 12001
"N-1.23E2"	Enters -1.23×10^2
"N+154.33E-1"	Enters 1.5433×10^1

The N command enters numeric values for use with subsequent Put commands. The interpretation of the numeric value depends on which Put command it is used with.

The E can be used within an N command for entering an exponent of 10. The N can be used without an E, but an E requires a prior N. The exponent can be any integer from -9 to +9.

The mantissa may exceed 5-1/2 digits. The 8842A accurately calculates the appropriate exponent and then disregards all but the first 5-1/2 digits of the mantissa. However, a syntax error will occur if the numeric entry overflows the input buffer.

<i>Example</i>	<i>Explanation</i>
"N123456789"	Enters $+1.23456 \times 10^8$

3-22. Put Commands

The Put commands P0 through P3 set up the 8842A's configuration and operating modes by entering ("putting") information in the appropriate registers. The put commands are described further in the following paragraphs.

3-23. P0 (Put Instrument Configuration)

<i>Format</i>	<i>Explanation</i>
N<frst>P0	Where <frst> is a four-digit integer interpreted as arguments for the F, R, S, and T commands.
<i>Example</i>	<i>Explanation</i>

"N3120 P0" Identical to F3 R1 S2 T0. Selects 2 WIRE k Ω function, 200 Ω range, fast sample rate, continuous trigger.

The P0 command allows broadside loading of the Function, Range, Reading Rate, and Trigger Mode commands (F, R, S, and T). The codes for these commands are listed in Figure 3-5.

A numeric entry for P0 must be within +1000 and +6824. Each of the four digits must not exceed its maximum allowed value (6, 8, 2, and 4, respectively) or an error message will occur and the instrument configuration will remain unchanged. The entry may be expressed as an integer, real number, or real number with exponent, as described under the N command. Any fractional part is ignored.

<i>Example</i>	<i>Explanation</i>
"N3112 P0"	Sets the 8842A to F3, R1, S1, and T2.

3-24. P1 (Put SRQ Mask)

<i>Format</i>	<i>Explanation</i>
N<SRQ mask>P1	Where <SRQ mask> is a two-digit integer from 00 to 63.

The P1 command is used to program the 8842A to make service requests on user-specified conditions. The two-digit code for the SRQ mask is interpreted in Table 3-1 under the G1 command. For more about the SRQ mask, see paragraph 3-51.

Numeric entries for the P1 command must be between 0 and +63 (inclusive), or an error will occur and the SRQ mask will remain unchanged. The entry may be expressed as an integer, real number, or real number with exponent, as described under the N command. Any fractional part is ignored.

<i>Example</i>	<i>Explanation</i>
"N0.17E+2 P1"	Sets SRQ mask to 17. Enables SRQ on data available or overrange.
"N1 P1"	Sets SRQ mask to 01. (A leading zero is assumed.) Enables SRQ on overrange.

3-25. P2 (Put Calibration Value)

<i>Format</i>	<i>Explanation</i>
N<value>P2	Where <value> can be an integer, real number, or real number with exponent, as described under the N command.

<i>Example</i>	<i>Explanation</i>
"N1 P2"	If the 8842A is in VDC, the next calibration input expected is 1.00000V dc.

The P2 command is used to enter variable input calibration values just like the front panel VAR IN button. To accept the P2 command, the 8842A must be in the calibration mode (enabled by pressing the front panel CAL ENABLE switch). Otherwise, the P2 command will generate an error message.

The variable input is a measurement value that is to be used as the calibration value for the next calibration step. Its format is the same as a measurement value. But since it is coming from the controller, the value can be specified using any valid format (signed integer, real number, or real number with exponent). For example, if the 8842A prompts for an input value of 100 Ω for the next calibration step, but the available source is 98.97 Ω , the variable input can be specified as "N+9.897E+1", "N0.9897E2", "N9897E-2",

etc. All of these strings result in the same value being used for the next calibration step. For complete information about remote calibration, refer to the Maintenance section.

Numeric values exceeding full scale and negative values for ohms and AC generate error messages.

3-26. P3 (Put User-Defined Message)

<i>Format</i>	<i>Explanation</i>
P3<value>	Where <value> is a string of up to 16 ASCII characters.
<i>Example</i>	<i>Explanation</i>
"P3FL.8842.12-17-83"	Loads the message "FL.8842.12-17-83" into calibration memory.
"P3HIMOM"	Loads the message "HIMOM" into calibration memory. The remaining eleven characters are assumed to be blank.

The P3 command stores a user-defined message in the internal calibration memory during remote calibration. The message may be read with a subsequent G3 command.

The message may consist of up to 16 ASCII characters, and typically represents the instrument's identification, calibration date, calibration facility, etc. If fewer than 16 characters are specified, spaces are appended to fill the message to 16 characters. Spaces and commas in the 16-character input string are suppressed. Lower-case letters are converted to upper-case.

NOTE

If fewer than 16 characters are specified, the P3 command must not be followed by other commands in the same input command string. Otherwise, the subsequent commands will be misinterpreted as part of the 16-character string.

To accept the P3 command, the 8842A must be in the calibration mode (enabled by pressing the front panel CAL ENABLE switch). Otherwise, the P3 command will generate an error message.

3-27. Rn (Range Commands)

The Range commands duplicate the front panel range buttons. For example, R0 selects autorange, and R3 selects the 20V/20 kQ range.

The R7 command turns autorange off, just as the AUTO button does when it is toggled. Command R7 puts the 8842A into manual range, selecting whatever range the instrument is in when the command is received.

The 8842A defaults to R0 on power-up and any device-clear command (*, DCL, or SDC). The range setting can be read using the G0 command.

3-28. Sn (Reading Rate Commands)

The Reading Rate commands duplicate the front panel RATE button. Like the RATE button, the reading rate command also selects the number of digits displayed and the filter setting. (Filter settings are shown in the specifications in Section 1).

The 8842A defaults to S0 on power-up and any device-clear command (*, DCL, or SDC). The reading rate can be read using the G0 command.

3-29. Tn (Trigger Mode Commands)

The Trigger Mode commands duplicate the front panel EX TRIG button. In addition, the commands can enable or disable the rear panel trigger and the automatic settling time delay.

Figure 3-7 illustrates how to select among the five types of triggers: continuous trigger, front panel trigger, rear panel trigger, and two bus triggers. Note that the front panel TRIG button is enabled only while the instrument is under local control.

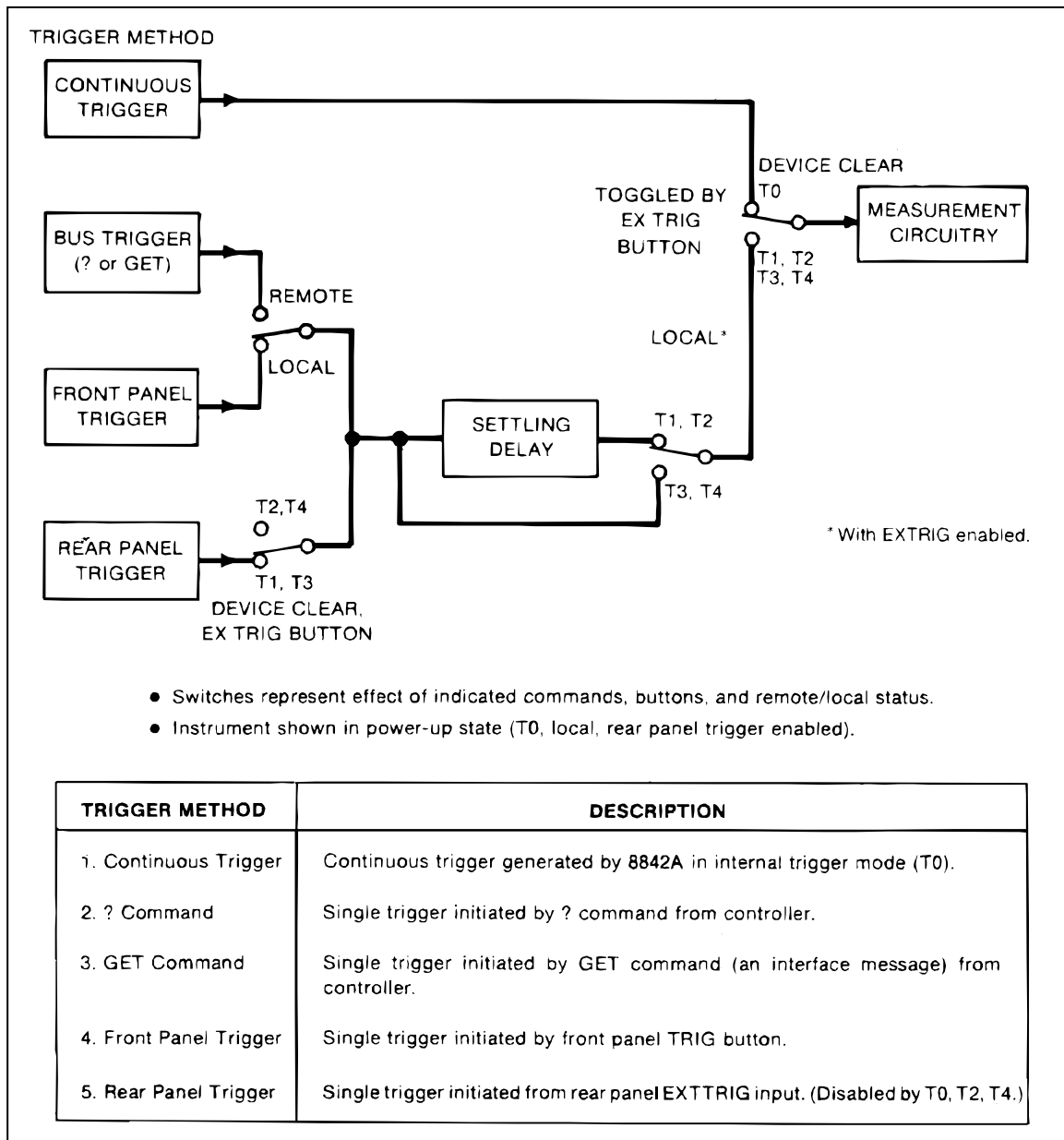

Figure 3-6. Trigger Selection Logic Diagram

f3-07.wmf

In the continuous trigger mode (T0), triggers are initiated at the selected reading rate. Each new reading is loaded into the output buffer as it becomes available, unless the instrument is busy sending previous output data.

The trigger mode can be read using the G0 command. The 8842A defaults to T0 on both power-up and any device-clear command (*, DCL, or SDC).

3-30. Wn (Terminator Commands)

The Terminator commands select what terminators the 8842A appends to every output string. The available terminators are: Carriage Return (CR), Line Feed (LF), and End Or Identify (EOI).

CR and LF are ASCII control codes, sent over the data lines just like output data. EOI is a uniline message which is sent simultaneously with the last character in the output string. Normally, each output string is terminated with CR followed by LF and EOI.

The terminator selection can be read using the G6 command. The 8842A defaults to W0 on power-up and any device-clear command.

3-31. X0 (Clear Error Register Command)

The X0 command clears the 8842A's error status register. After an X0 command is executed, a G7 command (Get Error Status) would return 1000 (no errors).

Note that the error status register is also cleared when any device-clear command (*, DCL, or SDC) is executed. However, X0 is useful for clearing the error status register without forcing a complete instrument clear (as do the device-clear commands).

3-32. Yn (Suffix Commands)

The Suffix commands enable or disable a suffix which the 8842A can append to all numeric data (the data in response to G2 or trigger commands). The suffix includes a comma, an overrange indicator (>), and a function indicator (VDC, VAC, OHM, IDC, or IAC). The suffix is illustrated in Figure 3-6. An example of suffixed data is given in paragraph 3-43.

To read suffixed data with a controller using BASIC, one can read the whole line into a string variable and then convert the numeric part into a numeric variable. However, it is much easier to read the numeric part directly into a numeric variable and the suffix into a string variable. The leading comma of the suffix serves as a convenient delimiter. For example, a BASIC program statement might be:

```
INPUT @1,A, B$
```

The suffix status can be read using the G6 command. The 8842A defaults to Y0 on power-up and any device-clear command (*, DCL or SDC), unless in talk-only mode.

3-33. Z0 (Self-Test Command)

The Z0 command initiates the diagnostic self-tests as does pressing the front panel SRQ button for 3 seconds. The 8842A then runs through the tests in sequence. (For a description of the self-tests, see the Maintenance section.)

If the 8842A detects an error, an error message is loaded into the output buffer and displayed on the front panel. After the last test, the 8842A is reset to the power-up configuration, and it begins taking readings.

It is an error to send the 8842A device-dependent commands during the self-tests. However, the controller can still make the 8842A a talker to read the output buffer during the test, and thus record each error that occurs, except that only the last of the digital self-test errors can be read. After the tests, only the last error is stored in the output buffer if more than one error occurred.

Error messages are indicated by an exponent of +21. For more about error messages, see paragraph 3-40.

Since the 8842A is reset at the end of the self-tests, the Z0 command should be the last command in a given command string. The 8842A will ignore any subsequent commands in the same command string.

When the self-tests are complete and no errors have occurred, the serial poll register will have bit 5 (Data Available) true and bit 6 (Any Error) false. See paragraph 3-50 for more about the serial poll register.

3-34. (Device-Clear Command)

The asterisk command (*) is a device-dependent message which resets the 8842A to the power-up default settings and clears all registers and buffers except for the input buffer. The remote/local status remains unchanged. The asterisk command performs the following:

1. Implements the default settings F1, R0, S0, T0, D0, B0, Y0, W0.
2. Clears the error status register (equivalent to X0).
3. Zeros the SRQ mask, prohibiting service requests (equivalent to N0 P1).
4. Zeros the numeric entry register (equivalent to N0).
5. Zeros the serial poll register.
6. Sets the SRQ line false.

The asterisk command is executed in its proper turn in a string, just like any other command, without affecting the contents of the input buffer. All commands which precede the asterisk command are performed.

The asterisk command is useful to ensure that the 8842A is initialized to the same state each time a program is run. By contrast, the similar interface messages DCL (Device Clear) and SDC (Selected Device Clear) cause the entire input buffer to be cleared immediately.

DCL, SDC, and the asterisk command are all considered to be device-clear commands because the results are so similar; however, DCL and SDC are not identical to the asterisk command described here. DCL and SDC are discussed further in the paragraph on interface messages.

3-35. ? (Single-Trigger Command)

The Single-Trigger command (?) causes the 8842A to take a reading and place the result into the output buffer. To accept this command, the 8842A must be in external trigger mode (selected by the T1, T2, T3, or T4 command).

The Single-Trigger command is one of five ways to trigger a reading. (See Figure 3-7.) Of these, only the Single-Trigger command (?) and the Group Execute Trigger command (GET) are loaded into the input buffer.

3-36. INPUT SYNTAX

The following paragraphs describe how to construct groups of commands for the 8842A. A few definitions are presented first, followed by a description of how the 8842A processes input commands. Guidelines are then summarized in four syntax rules.

3-37. Definitions

- Output commands: Commands which load data into the output buffer. The output commands are: the Get commands (G0 through G8); the Single-Trigger Command (?); the Continuous Trigger command (T0); and Group Execute Trigger (GET), not to be confused with the Get commands.
- Input terminator: An ASCII control code sent by the controller which tells the 8842A to execute all device-dependent commands since the previous terminator. Terminators are CR (Carriage Return), LF (Line Feed), EOI (End Or Identify), and GET (Group Execute Trigger).
- Input command string: One or more device-dependent commands followed by a terminator.

3-38. Input Processing

When the 8842A receives commands from the bus, it stores them in a 31-character input buffer as a continuous string of characters. Commands in the input buffer are not executed or checked for syntax until an input terminator is received or the input buffer becomes full. The only valid input terminators are CR, LF, GET (Group Execute Trigger), and/or EOI.

When the 8842A receives an input terminator, it executes the previous commands in the order in which they were received. As input characters are processed and executed, space is made available in the input buffer for new characters.

If the input buffer becomes full, the 8842A stops accepting characters from the bus until all complete command strings currently in the input buffer have been executed. In this way, characters sent to the 8842A are never lost due to buffer overflow.

In some instances, a terminator is automatically transmitted at the end of the controller's output string. For example, in Fluke BASIC, the PRINT statement always finishes with a CR LF pair. If a controller does not have this feature, the programmer must transmit a terminator explicitly.

The 8842A accepts alphabetic characters in either upper or lower case. Spaces, commas, and control codes are ignored and are not placed in the input buffer. If the 8842A receives a group of terminators (such as CR LF or CR LF EOI), only a single terminator is loaded into the input buffer. Numeric values used in PUT commands may be in NR1, NR2, or NR3 format as described in the IEEE-488 Codes and Formats Recommended Practice. (These correspond to the signed integer, real number, and real-number-with-exponent formats described under the N command.) For reference, Figure 3-8 shows how the 8842A interprets messages.

DEVICE-DEPENDENT MESSAGES	
Single-character Commands	
Bn Cn Dn Fn Gn Pn Rn Sn Wn Xn Yn Zn	Each of these commands requires the single numeric digit (n).
Numeric-entry Characters	
NE. + - 0123456789	These characters are used for entering numbers
Terminators	
CR	Carriage Return
LF	Line Feed
GET	Group Execute Trigger
EOI	End Or Identity (used as END/DAB)
INTERFACE MESSAGES	
Address Messages	
MLA	My Listen Address
MTA	My Talk address
UNL	Unlisten
UNT	Untalk
Universal Commands	
ATN	Attention
DCL	Device Clear
IFC	Interface Clear
LLO	Local Lockout
REN	Remote Enable
SPD	Serial Poll Disable
SPE	Serial Poll Enable
Addressed Commands	
GET	Group Execute Trigger
GTL	Go to Local
SDC	Selected Device Clear
Ignored Characters	
, comma	These characters may be inserted anywhere in a character string without affecting the string.
Space	Character string without affecting the string.
All Other ASCII non-printing characters (except CR and LF)	They carry no special meaning and are ignored by the 8842A. They are not placed in the input buffer.
ERROR-PRODUCING CHARACTERS	
! " # \$ ' () / : < = > ; @ [/] ~ HIJKLMOQUV	The error annunciator is displayed on the 8842A front panel when one of these characters is encountered (ERROR 71).

Figure 3-7. Interpretation of Messages

Illegal commands (e.g., F9) generate an error message, but are otherwise ignored, and do not affect the instrument's configuration.

<i>Example</i>	<i>Explanation</i>
"* F9"	This would load the output buffer with an error message and select F1 (established by the * command).

3-39. **Syntax Rules**

Four syntax rules should be followed when constructing input command strings. They are:

- **RULE 1: Read output data only once.**
To prevent old (previously read) data from being read a second time by mistake, the output buffer is always cleared after it has been read. If the output buffer is read twice without an intervening output command, the 8842A will not respond to the second attempt to read the output buffer. (However, if the 8842A is in T0, no intervening command is necessary.)
- **RULE 2: Use no more than one output command per input command string.**
Because the 8842A has only one output buffer, it writes new data over old. If an input command string contains more than one output command, only the data from the last command can be read.

<i>Example</i>	<i>Explanation</i>
"F1 T3 ? F2 ?"	Improper construction. The second trigger writes over the first. To obtain two readings, send two complete command strings (separated by terminators).
"F2 R3 S0 T3 ?"	Correct construction. The string contains only one output command.
"F2 R3 S0"	Correct construction. It is permissible for a string not to contain an output command.

- **RULE 3: Read the output data generated by one input command string before sending the next input command string.**
Output data remains available in the output buffer until it is read, or until the next input command string is received. As soon as the controller finishes reading the output buffer, or as soon as the 8842A receives a new input terminator, the Data Available bit in the serial poll register is set false. When this bit is false, data can no longer be read from the output buffer. Therefore, an output string which is available must be read by the controller before, rather than after, the next input command string is sent.

Rule 3 is most evident in the external trigger mode, and is best demonstrated by a programming example. The following program is written first incorrectly, and then correctly, in Fluke BASIC using the 1722A Instrument Controller.

Incorrect example

```

100 PRINT @3, "T1 ?"
200 PRINT @3, "F4"
300 INPUT @3, A

```

In this incorrect example, the INPUT statement is located incorrectly for reading the measurement data from line 100. The new input command string "F4" disallows the reading of data from the output buffer.

Correct example

```
100 PRINT @3, "T1 ?"  
200 INPUT @3, A  
300 PRINT @3, "F4"
```

In this example, the reading taken at line 100 is read at line 200. Then the F4 command is sent. Note that in the external trigger mode, the reading from line 100 flashes on the 8842A display too briefly to see. This is because the function change at line 300 blanks the display until the next trigger.

The previous example could also be correctly programmed as follows:

```
100 PRINT @3, "T1 ? F4"  
200 INPUT @3, A
```

- **RULE 4:** If an input command string contains a trigger, enter the commands in the following order:
 - a. Commands to configure the instrument (if any).
 - b. The trigger command.
 - c. Commands to re-configure the instrument (if any).
 - d. Terminator(s).

The principle behind this rule is that the 8842A executes all commands in the exact order they are received, from left to right as written.

<i>Example</i>	<i>Explanation</i>
"F3 F4 ?"	Improper construction. F3 is effectively discarded.
"F3 ? F4"	Correct construction. The 8842A is configured in F3, and the trigger is executed. Then the 8842A is left in F4.

3-40. OUTPUT DATA

The following paragraphs describe the data that can be loaded into the 8842A output buffer and sent to the IEEE-488 bus. The paragraphs describe how and when data is loaded into the output buffer, the types of output data, and their relative priority.

Note that the 8842A can also send data to the IEEE-488 bus from the serial poll register. For a description of this data, see paragraph 3-47.

3-41. Loading Output Data

The output buffer is loaded when the 8842A receives an output command, or when an error occurs. Output commands are those device-dependent commands which load the output buffer with data:

- Get commands (G0 through G8)
- Single-trigger command (?)
- Group execute trigger (GET)
- Continuous Trigger (T0)

Because the 8842A gives priority to input processing, it completely processes all characters in the input buffer before it loads the output buffer. When the output buffer is loaded, the Data Available bit in the serial poll register is set true.

Data from the output buffer is not actually loaded onto the IEEE-488 bus until the controller addresses the 8842A as a talker. This is done by sending the interface message MTA (My Talk Address).

3-42. Types of Output Data

The types of data that can be loaded into the output buffer are shown in Figure 3-6. Each type has its own format. Error messages, which are loaded into the output buffer if an error occurs, are formatted as numeric data.

3-43. Numeric Data and Error Messages

Numeric data is loaded into the output buffer in response to the G2 command or an instrument trigger, and has the format shown in Table 3-2. The exponent is always a multiple of 3, as in engineering notation. The position of the decimal point matches the front panel display.

Numeric data is of constant length, It is 11 characters (plus terminators) when the suffix is disabled, and 16 characters (plus terminators) when the suffix is enabled.

The suffix is enabled by the Y1 command, and consists of five ASCII characters as shown in Figure 3-6. The suffix is appended only to numeric data, never to status data. The terminators are determined by the Terminator commands. The default is CR LF EOL.

There are three types of numeric data: measurement data, overrange indication, and error messages.

3-44. MEASUREMENT DATA

Measurement data has the numeric data format shown in Table 3-2, and is always in the units of volts, amps, or ohms.

Table 3-2. Numeric Output Data Format

RANGE	MEASUREMENT DATA			OVERRANGE INDICATION	ERROR MESSAGES
	VDC, VAC	2-, 4-WIRE kΩ	MA DC, mA AC		
R8	±1x.xxxxE-3*	±1x.xxxxE+0**	--	±9.99999E+9	+1.00xxE+21
R1	±1xx.xxxE-3	±1xx.xxxE+0	--	±9.99999E+9	+1.00xxE+21
R2	±1.xxxxxE+0	±1.xxxxxE+3	--	±9.99999E+9	+1.00xxE+21
R3	±1x.xxxxE+0	±1x.xxxxE+3	--	±9.99999E+9	+1.00xxE+21
R4	±1xx.xxxE+0	±1xx.xxxE+3	±1xx.xxxE-3***	±9.99999E+9	+1.00xxE+21
R5	±1xx.xxE+0	±1xx.xxE+3	±1xx.xxE-3	±9.99999E+9	+1.00xxE+21
R6	--	±1x.xxxxE+6	--	±9.99999E+9	+1.00xxE+21
* VDC only ** 4-wire ohms *** mA DC only					

NOTE

In the fast (F) reading rate, the least significant digit is always zero, and should be disregarded when interpreting accuracy specifications.

3-45. OVERRANGE INDICATION

If a reading is overrange ($\geq 200,000$ counts), the measurement data has the following format:

$\pm 9.99999\text{E}+9$ <suffix> <terminators>

Overvoltage readings ($> 1000\text{V}$ dc or 700V ac) do not result in this display.

3-46. ERROR MESSAGES

If the 8842A detects an error, it loads an error message into the output buffer in the following numeric format:

$+1.00\text{xxE}+21$ <terminators>

The digits xx represent a two-digit error code. (Error codes are listed in Table 2-1, Section 2.) The suffix is always suppressed for error messages.

<i>Example</i>	<i>Explanation</i>
----------------	--------------------

$+1.0071\text{E}+21$ CR LF	ERROR 71: Syntax error in device-dependent command string.
----------------------------	--

As with local operation, none of the errors are latching except for ERROR 31. If the mA DC or mA AC function is requested while the FRONT/REAR switch is in the REAR position, ERROR 31 will persist until the switch is set to FRONT or another function is selected.

To check for an error condition, test whether the output buffer data is greater than or equal to $+1\text{E}+21$, or test the Any Error bit (bit 6) in the serial poll register.

3-47. Status Data

Status data is the output in response to G0, G1, G3, G4, G5, G6, G7 and G8, commands. The data is formatted as shown in Figure 3-2, and is interpreted in Table 3-1. Examples of status data can be found in the description of the Get commands.

The user-defined message loaded by the G3 command consists of 16 characters plus terminators. The SRQ mask loaded by the G1 command consists of two integers plus terminators. All other status data is always a four-digit integer plus terminators. The terminators LF (Line Feed) and CR (Carriage Return) each add an extra character when enabled.

The 8842A begins some status data with a leading ASCII one (1) or a one and a zero (10). This prevents the controller from suppressing any leading zeros present in the 8842A's output string. It also gives a uniform four-character length to all instrument configuration data.

Status data from the Get commands reflects the status of the 8842A at the time the command is executed at its place in the input command string.

3-48. Output Priority

Since only one output string is allowed per input command string, the 8842A gives priority to some types of data over others. An input command string may call for more than one output string. (For example, an input string may contain a Get command but also cause an error message.) However, the output buffer is loaded with only one output string. That string is selected according to the following priority:

1. Status data (from G0, G1, G3, G4, G5, G6, G7 and G8)
2. Error messages (if an error exists)
3. Numeric data (from G2 or a trigger)

This means that an error message always overrides numeric data, but status data is sent even in the presence of an error. However, the status data does not clear the error message; the error message is sent the next time numeric data is requested.

3-49. SERVICE REQUESTS

Service requests let bus instruments get the attention of the system controller. The requests are sent over the SRQ line (one of the IEEE-488 bus lines). If more than one instrument on the bus is capable of sending service requests, the controller can learn which one made the request by taking a serial poll. Each device (including the 8842A) responds to the poll by sending the contents of its serial poll register. The serial poll register indicates whether or not the device requested service, and if so, the reason for the request.

The 8842A may be programmed to make a service request on user-specified conditions. The conditions are specified by entering a value for the service request mask (SRQ mask) with the P1 command. The SRQ mask works by monitoring the serial poll register, which in turn monitors various conditions in the 8842A.

3-50. The Serial Poll Register

The serial poll register is a binary-encoded register which contains eight bits, as illustrated in Figure 3-9. The controller can read the 8842A serial poll register at any time by taking a serial poll. Because serial poll register data is loaded directly onto the bus (instead of being loaded into the output buffer first), reading the serial poll register leaves data in the output buffer intact.

Service requests may also be initiated using the front panel SRQ button if it has been enabled by the SRQ mask.

The eight bits of the serial poll register are described in Figure 3-9. Note that the SRQ mask uses bits 1 through 6 to set bit 7 (the RQS bit). When the RQS bit is set true, the 8842A sets the SRQ line true, which generates a service request. A bit is considered true when it is set to 1.

BIT: 8	7	6	5	4	3	2	1
0	RQS	ANY ERROR	DATA AVAILABLE	CAL STEP COMPLETE	FRONT PANEL SRQ	0	OVER-RANGE
DECIMAL VALUE:	64	32	16	8	4	2	1

Bit	Name	Set	Cleared
1	Overrange	An overrange condition occurs	Device command received, or Bus or Rear Panel Trigger, or Output buffer is read
2	Not used	Never	Always
3	Front panel SRQ	Front panel SRQ button pressed	Device command received
4	Cal Step Complete	Completion of store command (C0)	Device command received
5	Data Available	Output buffer loaded with any data (Readings, Error Messages, Get Responses)	Device command received, or Bus or Rear Panel Trigger, or Output buffer is read
6	Any Error	An error condition occurs. At the same time the output buffer is loaded with an error message. This sets bit 5.	Device command received, or Output buffer is read
7	RQS	Any SRQ mask-enabled bit is set.	All SRQ mask-enabled bits are cleared
8	Not used	Never	Always

Figure 3-8. Serial Poll Register

For example, the serial poll register reads 00010000 (binary) when data is available. This value is read in binary by the controller, which might numerically reformat the value to 16 (decimal) or 10 (hexadecimal).

The serial poll register is cleared whenever the 8842A receives a new input command string.

3-51. The SRQ Mask

The SRQ mask is a two-digit integer that specifies which conditions will generate a service request. The SRQ mask is entered using the P1 command and can be read with the G1 command. The conditions corresponding to each SRQ mask value are listed under G1 in Table 3-1.

The SRQ mask can enable any combination of serial poll register bits 1 through 6. Its six-bit binary representation is ANDed bit-for-bit with serial poll register bits 1 through 6 whenever the output buffer is loaded. If any mask-enabled bit in the serial poll register comes true, the RQS bit (bit 7) is set true, generating a service request.

Example *Explanation*

"* N4 P1 ?" An SRQ is generated if the front panel SRQ button is pressed. The string sets the SRQ mask to 04, which is 000100 in binary. This mask is ANDed with the lower six bits of the serial poll register. The mask thus enables bit 3, the Front Panel SRQ bit.

The SRQ mask codes can be added to select combinations of conditions.

Example *Explanation*

"* N5 P1 ?" An SRQ is generated if the SRQ button is pressed or if the trigger results in an overrange reading. The SRQ mask is set to 05, which is 000101 in binary.

At power-up or on any device-clear command, the SRQ mask is set to 00 (decimal). This prevents service requests by holding the RQS bit false under all conditions. For other examples of the SRQ mask, see the description of the P1 command.

3-52. INTERFACE MESSAGES

The interface messages understood by the 8842A can be separated into the three main classes described in the IEEE-488 Standard: address messages (AD), universal commands (UC), and addressed commands (AC). All interface messages described here originate at the controller.

3-53. Address Messages

Address messages are used by the controller to communicate talk and listen control to other devices on the bus. Address messages are sent over the eight data lines of the bus while the controller holds ATN true. Address messages are processed immediately and are not placed in the input buffer. The address messages are:

- MLA My Listen Address -- Addresses a device to listen
- MTA My Talk Address -- Addresses a device to talk
- UNL Unlisten -- Addresses all listeners to unlisten
- UNT Untalk -- Addresses all talkers to untalk

3-54. Universal Commands

Universal commands are accepted and interpreted by all devices on the bus. The commands are of two types, multiline messages and uniline messages. Multiline messages are sent over the eight parallel data lines in the IEEE-488 bus. Uniline messages are sent over one of the individual interface management lines in the IEEE-488 bus. All universal commands except DCL are processed immediately by the 8842A, ahead of any device-dependent commands. Only DCL enters the 8842A input buffer.

The 8842A responds to the following universal messages:

ATN Attention -- A uniline message which causes the 8842A to interpret multiline messages as interface messages (AD, AC, or UC). When false, multiline messages are interpreted as device-dependent messages.

- IFC Interface Clear -- A uniline message which clears only the interface (not the 8842A) by placing it in a known quiescent state.
- REN Remote Enable -- A uniline message which, when received with MLA, switches the 8842A to remote. When REN is set false, the 8842A switches to local and removes local lockout.
- DCL Device Clear -- A multiline message which is loaded into the input buffer as a special device-clear command. DCL performs the same operation as the device-dependent command *, except that it is read before any other characters that are already present in the input buffer, and clears the entire input buffer. Processing then continues normally. The action of DCL is not immediate; if the 8842A is taking a reading when DCL is received, the DCL command is executed after the measurement is finished.
- LLO Local Lockout -- A multiline message which disables the front panel LOCAL button. The result is that the local mode is not accessible by front panel control.
- SPD Serial Poll Disable -- A multiline message which removes the serial poll enable state.
- SPE Serial Poll Enable -- A multiline message which causes the serial poll data (rather than output buffer data) to be transferred on the bus once ATN becomes false.

3-55. Addressed Commands

Addressed commands are multiline messages which are accepted and interpreted by only those devices currently addressed to listen. The 8842A responds to the following addressed commands:

- GET Group Execute Trigger -- (Not to be confused with the device-dependent Get commands.) GET loads a trigger command into the input buffer and also terminates the string at that point. Only a single character is loaded into the input buffer. The trigger command is executed in its proper turn in the input string, rather than immediately. When executed, GET initiates a measurement.
- GTL Go To Local -- Causes the 8842A to switch to local. This command does not enter the input buffer. If the display has been blanked (with a D1 command), issue a D0 command before sending GTL.
- SDC Selected Device Clear -- Identical to the universal command DCL, but is accepted and interpreted by current listeners only. Therefore, it clears the 8842A only if it is addressed to listen.

3-56. TALK-ONLY MODE

The talk-only mode lets you take advantage of the remote capability of the 8842A without having to use an instrument controller. To put the 8842A in the talk-only mode:

1. Turn the 8842A POWER switch OFF.
2. Set the rear panel TALK ONLY bit switch to 1 (the up position).
3. Connect the 8842A via the IEEE-488 bus to your printer, data logger, or other device.
4. Configure the other device as a listener only.
5. Turn the 8842A POWER switch ON.

6. Configure the 8842A with the front panel controls.

The 8842A reads the TALK ONLY bit switch on power-up and when it receives the interface command IFC. You can therefore set the TALK ONLY switch to 1 after power-up as long as you then send the 8842A the IFC command.

3-57. REMOTE CALIBRATION

The 8842A can be calibrated over the IEEE-488 bus using remote commands. Refer to the Maintenance section for details.

3-58. TIMING CONSIDERATIONS

To help you take the best advantage of the speed of the 8842A, external trigger timing for the IEEE-488 Interface is described in the specifications in Section 1.

3-59. IMMEDIATE MODE COMMANDS

Many controllers have some amount of "immediate mode" capability. That is, commands may be given interactively to the 8842A via the run-time-system without the need for actually running a program. The controller accepts and executes these commands one at a time. Some commonly used commands are listed in Table 3-3 for several controllers. These are provided for the convenience of instrument demonstrations, set-up and check-out, and for those with limited experience with IEEE-488 bus operations.

As a general note: The entire 8842A command set should work well provided the "port clear" and "device clear" commands are given first. You should then be able to send any other commands in the 8842A command set without repeating the clearing commands.

Table 3-3. Immediate-Mode Commands for Various Controllers

FUNTION PERFORMED	FLUKE-BASIC on 1720A or 1722A	HP-HPL on HP9825 Calculator	HP-BASIC on HP9816-PC and HP-85 Calculator	TEK-BASIC on 4051 Graphics System
INITIALIZE Port	INIT PORT 0	cli 7	CLEAR 7	INIT
CLEAR Instrument	CLEAR @4	cir 704	CLEAR 704	PRINT @4: ""
REMOTE Commands	REMOTE @4	rem 704	REMOTE 704	WBYTE @36, 17:
LOCAL Control	LOCAL @4	lcl 704	LOCAL 704	WBYTE @36, 1:
EXTERNAL TRIGGER	PRINT @4,"T1"	wrt 704,"T1"	OUTPUT 704;"T1"	PRINT @4:"T1"
TRIGGER Instrument	TRIG @4	trg 704	TRIGGER 704	PRINT @4:"?"
GET Output Data	INPUT @4,A	red 704, A	ENTER 704;A (Note 2)	INPUT @4:A
PRINT Data to Screen	PRINT A	prt A	PRINT A (Note 2)	PRINT A
CONFIGURE for VAC	PRINT @4,"F2"	wrt 704,"F2"	OUTPUT 704;"F2"	PRINT @4:"F2"
CONFIGURE for 200Vac	PRINT @4,"R4"	wrt 704;"R4"	OUTPUT 704;"R4"	PRINT @4:"R4"
TRIGGER Continuously	PRINT @4,"TO"	wrt 704,"TO"	OUTPUT 704; "TO"	PRINT @4:"TO"
SUFFIXES Enable	PRINT @4,"Y1"	wrt 704,"Y1"	OUTPUT 704;"Y1"	PRINT @4:"Y1"
GET Data & Suffix	INPUT @4, A,A\$	Red 704,A,A\$ (Note 1)	ENTER 704;A,A\$ (Note 2)	INPUT %4:A,A\$
PRINT Data & Suffix	PRINT A,A\$	Prt A\$,A	PRINT A,A\$ (Note 2)	PRINT A,A\$

Notes:

- Before using A\$ on the 9825 is necessary to enter "dimA\$[6]" to allocate a string variable. This statement allows six characters.
- In the HP9816 system, variables cannot be created from the keyboard; they must be created by running a program. (See error 910 for that system.) To get around this, type in a very short program as follows:

```

SCRATCH      (Hit "EXEC" key)
10 A = 0     (Hit "ENTER" key)
20 A$ = ""   (Hit "ENTER" key)
30 END      (Hit "ENTER" key)
              (Hit "RUN" Key)

```

This program creates the variables 'A' and 'A\$' so that they may be accessed in immediate mode and changed at will. This program is not necessary for the HP-85 Calculator.

3-60. EXAMPLE PROGRAMS

Several example programs for the 8842A using various controllers are presented in the remaining figures in this section. In all of these examples, the 8842A is set to IEEE-488 address 4 (rear panel switch setting 000100). Of course, any other address (00 to 30) could be substituted.

In each of these examples, the instrument is cleared prior to configuration set-ups. This ensures that the 8842A configuration has been completely defined.

To run these programs, it is not necessary to type in all the comments (which appear to the right of the exclamation marks). Also, spaces are placed between commands for ease of reading; they are not required.

```
1! This program selects VDC (F1), Autorange (R0), Slow rate (S0), continuous trigger (T0) and
2! suffixes enabled (Y1). The program takes 10 readings and stops. The 8842A is addressed on
3! port 0, device #4 under control of a Fluke 1720A or 1722A Instrument Controller.
4!
5! In the INPUT statement, the controller assigns the first part of the 8842A output response
6! (the measurement value) to R, and assigns the second part (the suffix) to R$.
7!
8!                               FLUKE-BASIC on 1720A, 1722A
9!
20 INIT PORT 0                    !Clear Port
25 CLEAR PORT 0                  !Clear instr to default functions
35 PRINT @4, "F1 R0 S0 T0 Y1"    !Write functions to instrument
40 FOR I = 1 TO 10
45   INPUT @4, R, R$            !Get data from 8842A
50   PRINT "    ",I,R,R$       !Print to 1722A display
55 NEXT I
60 END
```

Figure 3-9. Example Program

f3-10.wmf

```

1! This is a sample program which commands the 8842A to the state of VDC, autorange, slow rate,
2! continuous trigger and suffixes enabled. All readings appear simultaneously on the
3! instrument display while being logged on the controller display with suffixes enabled for
4! function readout. Full local control is given to the 8842A so that any range or function
5! may be invoked easily. The controller always echos the 8842A display while this program
6! is running.
7!
8!           FLUKE-BASIC on 1720A, 1722A
9!
30 INIT PORT 0           !Clear Port
40 CLEAR PORT 0         !Clear instrument to default functions
50 WAIT 1000           !Wait 1 second before sending commands
60 PRINT @4, "F1 R0 S0 T0 Y1" !F1=VDC, R0=Autorange, S0=Slow rate
70!                   !T0=Continuous trigger, Y1=Enable suffix
80 X=0
90 LOCAL @4           !Give local control to instrument
95!
110 INPUT @4,A,A$      !Get reading and suffix from 8842A
120  X=X+1             !Increment reading count
130  PRINT "           ",X,A,A$ !Display reading and suffix
140  GOTO 110
200 END

```

Figure 3-10. Example Program: Taking Readings with Local Control

f3-11.wmf

```
1! The following program illustrates one possible use of the serial poll register. In this
2! case it is merely looking for data available. The instrument is addressed on port 0,
3! device #4 under control of a Fluke 1720A or 1722A instrument controller. The function
4! of this program is to display on the controller screen the lowest resistance measured
5! across the input terminals of the 8842A using the 2-wire ohms function in autorange.
6! The command string sets up the 8842A by using the Put Instrument Configuration command P0.
7!
8!                               FLUKE-BASIC on 1720A, 1722A
9!
100 INIT PORT 0 \ CLEAR PORT 0 \ WAIT 500 !Clear port, instrument, delay
110 PRINT @4, "N3001P0 Y1 ?"           !Instrument functions and trigger
120 INPUT @4, A,A$                     !Get first reading
130 PRINT " ",A,A$;"S (2-wire) Lowest Reading"
140 TRIG @4
160 B%=SPL(4)                          !Get serial poll register
170 IF (B%=0%) THEN 160                !Looking for data available
175 INPUT @4,R,A$                      !Get next data
180 IF R>=A THEN 140                   !Throw away data if not lowest
185 A=R                                 !Update lowest reading
190 GOTO 130                            !Print new low
900 END
```

Figure 3-11. Example Program: Using the Serial Poll Register

f3-12.wmf

```

10! This program demonstrates a method of recording any errors produced by the 8842A during self test.
20!
30! It should be noted that:
40!     1. If more than one digital test error occurs, only the last one will be reported.
50!     2. The response to the Get Instrument Configuration (G0) command during selftest is "9xxx".
60!     3. The response to a Get Error Status (G7) command with no errors present is "1000".
70!
80!                               FLUKE-BASIC on 1720A, 1722A
90!
100 DA%=4%                               !Device address #4
110 TIMEOUT 10000                          !10 second timeout
120 PRINT
130 PRINT "MONITORING SELFTEST"
140 INIT PORT 0                             !Initialize port
150 CLEAR @DA%                              !Clear device
160 PRINT @DA%, "Z0"                        !Start selftest
170!
180 PRINT @DA%, "G7" \ INPUT @DA%, E$
190 IF (E$ = "1000") THEN 220
200 PRINT @DA%, "X0"
210 PRINT "ERROR ";RIGHT(E$,3);" OCCURRED"  !Print analog errors
220 PRINT @DA%, "G0" \ INPUT @DA%, ST$
230 IF (ST$ >= "9000") GOTO 180
240 PRINT @DA%, "G7" \ INPUT @DA%, E$
250 IF (E$ = "1000") THEN 270
260 PRINT "ERROR ";RIGHT(E$,3);" OCCURRED"  !Print last digital error
270 PRINT "SELFTEST COMPLETE"
280 END

```

Figure 3-12. Example Program: Record Errors During Selftest

f3-13.wmf

```
10 REM The following application program is written in BASICA for the IBM PC, PC-XT or
20 REM PC-AT. The National Instruments Model GPIB-PCIIA board provides the interface
30 REM between the PC and the Fluke 8842A DMM. The program assumes that the configuration
40 REM program IBCONF has been run to initialize the interface board with the device
50 REM name I8842A assigned to the GPIB0 board.
60 REM
70 REM The first 6 lines of code are required to properly link the NI drivers to BASICA.
80 REM
90 REM
100 REM This program selects VDC (F1), Autorange (R0), Slow rate (S0), Continuous trigger (T0)
110 REM and suffixes enabled (Y1). The program takes 10 readings, displays them on the screen,
120 REM and then stops.
130 REM
140 REM
150 CLEAR ,59736!
160 IBINIT1 = 59736!
170 IBINIT2 = IBINIT1 + 3
180 BLOAD "bib.m",IBINIT1
190 CALL IBINIT1(IBFIND,IBTRG,IBCLR,IBPCT,IBSIC,IBLOC,IBPPC,IBBNA,IBONL,IBRSC,IBSRE,
IBRSV,IBPAD,IBSAD,IBIST,IBDMA,IBEOS,IBTMO,IBEOT,IBRDF,IBWRTF)
200 CALL IBINIT2(IBGTS,IBCAC,IBWAIT,IBPOKE,IBWRT,IBWRTA,IBCMD,IBCMDA,IBRD,IBRDA,IBSTOP,
IBRPP,IBRSP,IBDIAG,IBXTRC,IBRDI,IBWRTI,IBRDIA,IBWRTIA,IBSTA%,IBERR%,IBCNT%)
210 REM
220 REM          IBM BASICA on IBM PC, PC-XT or PC-AT
230 REM
240 DEVNAME$="I8842A"           'Device name is I8842A
250 CALL IBFIND(DEVNAME$,DVM%) 'Initialize the DMM
260 CALL IBCLR(DVM%)           'Clear the device
270 FOR W=1 TO 500 : NEXT W    'Wait 1 second before sending command
280 WRT$="F1R0S0T0Y1"
290 CALL IBWRT(DVM%,WRT$)      'Write functions to instrument
300 FOR I = 1 TO 10
310  RD$=SPACE$(18)           '11 characters for the reading, 5 for the
320                               'suffix and 2 for the terminators
330  CALL IBRD(DVM%,RD$)       'Get data from 8842A
340  PRINT I, LEFT$(RD$,16)    'Print to display
350 NEXT I
360 END
```

IBM®, IBM PC, PC-XT and PC-AT are registered trademarks of International Business Machine Corporation

National Instruments® is a registered trademark of National Instruments Corporation

Figure 3-13. Example Programs: Using the IBM PC

f3-14_01.wmf

```

10 REM The following application program is written in BASICA for the IBM PC, PC-XT or
20 REM PC-AT. The National Instruments Model GPIB-PCIIA board provides the interface
30 REM between the PC and the Fluke 8842A DMM. The program assumes that the configuration
40 REM program IBCONF has been run to initialize the interface board with the device
50 REM name I8842A assigned to the GPIB0 board.
60 REM
70 REM The first 6 lines of code are required to properly link the NI drivers to BASICA.
80 REM
90 REM This program illustrates one possible use of the serial poll register. In this
100 REM case it is merely looking for data available. The function of the program is to
110 REM display on the screen the lowest resistance value measured on the input terminals
120 REM of the 8842A using the 2-wire ohms function in autorange. The range and function
130 REM commands are programmed using the Put Instrument Configuration (P0) command.
140 REM
150 CLEAR ,59736!
160 IBINIT1 = 59736!
170 IBINIT2 = IBINIT1 + 3
180 BLOAD "bib.m",IBINIT1
190 CALL IBINIT1(IBFIND,IBTRG,IBCLR,IBPCT,IBSIC,IBLOC,IBPPC,IBBNA,IBONL,IBRSC,IBSRE,
IBRSV,IBPAD,IBSAD,IBIST,IBDMA,IBEOS,IBTMO,IBEOT,IBRDF,IBWRTF)
200 CALL IBINIT2(IBGTS,IBCAC,IBWAIT,IBPOKE,IBWRT,IBWRTA,IBCMD,IBCMDA,IBRD,IBRDA,IBSTOP,
IBRPP,IBRSP,IBDIAG,IBXTRC,IBRDI,IBWRTI,IBRDIA,IBWRTIA,IBSTA%,IBERR%,IBCNT%)
210 REM
220 REM          IBM BASICA on IBM PC, PC-XT or PC-AT
230 REM
240 DEVNAME="I8842A"           'Device name is I8842A
250 CALL IBFIND (DEVNAME$,DVM%) 'Initialize the DMM
260 CALL IBCLR (DVM%)         'Clear device
270 FOR W = 1 TO 500: NEXT W  'Wait 1 second before sending commands
280 WRT$ = "N3001P0 Y1 ?"
290 CALL IBWRT (DVM%,WRT$)    'Write functions to instrument
300 RD$ = SPACE$(18)         '11 characters for the reading, 5 for the
310                          'suffix and 2 for the terminators
320 CALL IBRD (DVM%,RD$)     'Get first reading from 8842A
330 R = VAL(RD$)
340 PRINT LEFT$(RD$,16);"S (2-WIRE) LOWEST READING"  'Display readings
350 WRT$ = "?"
360 CALL IBWRT (DVM%,WRT$)   'Trigger the 8842A
370 CALL IBRSP (DVM%,SPR%)   'Get serial poll byte
380 IF SPR% AND &H40 <> &H40 THEN 370 'Check for data available
390 RD$ = SPACE$(18)
400 CALL IBRD (DVM%,RD$)    'Get next data
410 S = VAL (RD$)
420 IF S >= R THEN 350      'Throw away data if not lowest
430 R = S                   'Update lowest reading
440 GOTO 340                'Print new low
450 END

```

f3-14_01.wmf

Figure 3-14. Example Programs: Using the IBM PC (cont)

```
10 REM The following application program is written in BASICA for the IBM PC, PC-XT or
20 REM PC-AT. The National Instruments Model GPIB-PCIIA board provides the interface
30 REM between the PC and the Fluke 8842A DMM. The program assumes that the configuration
40 REM program IBCONF has been run to initialize the interface board with the device
50 REM name I8842A assigned to the GPIB0 board.
60 REM
70 REM The first 6 lines of code are required to properly link the NI drivers to BASICA.
80 REM
90 REM This program illustrates one possible use of the serial poll register. In this
100 REM case it is merely looking for data available. The function of the program is to
110 REM display on the screen the lowest resistance value measured on the input terminals
120 REM of the 8842A using the 2-wire ohms function in autorange. The range and function
130 REM commands are programmed using the Put Instrument Configuration (P0) command.
140 REM
150 CLEAR ,59736!
160 IBINIT1 = 59736!
170 IBINIT2 = IBINIT1 + 3
180 BLOAD "bib.m",IBINIT1
190 CALL IBINIT1 (IBFIND,IBTRG,IBCLR,IBPCT,IBSIC,IBLOC,IBPPC,IBBNA,IBONL,IBRSC,IBSRE,
IBRSV,IBPAD,IBSAD,IBIST,IBDMA,IBEOS,IBTMO,IBEOT,IBRDF,IBWRTF)
200 CALL IBINIT2 (IBGTS,IBCAC,IBWAIT,IBPOKE,IBWRT,IBWRTA,IBCMD,IBCMDA,IBRD,IBRDA,IBSTOP,
IBRPP,IBRSP,IBDIAG,IBXTRC,IBRDI,IBWRTI,IBRDIA,IBWRTIA,IBSTA%,IBERR%,IBCNT%)
210 REM
220 REM          IBM BASICA on IBM PC, PC-XT or PC-AT
230 REM
240 DEVNAME="I8842A"           'Device name is I8842A
250 CALL IBFIND (DEVNAME$,DVM%) 'Initialize the DMM
260 CALL IBCLR (DVM%)         'Clear device
270 FOR W = 1 TO 500: NEXT W   'Wait 1 second before sending commands
280 WRT$ = "N3001P0 Y1 ?"
290 CALL IBWRT (DVM%,WRT$)     'Write functions to instrument
300 RD$ = SPACE$(18)          '11 characters for the reading, 5 for the
310                            'suffix and 2 for the terminators
320 CALL IBRD (DVM%,RD$)      'Get first reading from 8842A
330 R = VAL(RD$)
340 PRINT LEFT$(RD$,16);"S (2-WIRE) LOWEST READING" 'Display readings
350 WRT$ = "?"
360 CALL IBWRT (DVM%,WRT$)     'Trigger the 8842A
370 CALL IBRSP (DVM%,SPR%)     'Get serial poll byte
380 IF SPR% AND &H40 <> &H40 THEN 370 'Check for data available
390 RD$ = SPACE$(18)
400 CALL IBRD (DVM%,RD$)      'Get next data
410 S = VAL (RD$)
420 IF S >= R THEN 350         'Throw away data if not lowest
430 R = S                       'Update lowest reading
440 GOTO 340                   'Print new low
450 END
```

f3-14_02.wmf

Figure 3-14. Example Programs: Using the IBM PC (cont)

```

10 REM The following application program is written in BASICA for the IBM PC, PC-XT or
20 REM PC-AT. The National Instruments Model GPIB-PCIIA board provides the interface
30 REM between the PC and the Fluke 8842A DMM. The program assumes that the configuration
40 REM program IBCONF has been run to initialize the interface board with the device
50 REM name I8842A assigned to the GPIB0 board.
60 REM
70 REM The first 6 lines of code are required to properly link the NI drivers to BASICA.
80 REM
90 REM This program illustrates a method of recording any errors produced by the 8842A
100 REM selftest function. It should be noted that:
110 REM 1. If more than one digital error occurs, only the last one will be reported.
120 REM 2. The response to a Get Instrument Config. (G0) command during selftest is "9xxx".
130 REM 3. The response to a Get Error Status (G7) command with no errors present is "1000".
140 REM
150 CLEAR ,59736!
160 IBINIT1 = 59736!
170 IBINIT2 = IBINIT1 + 3
180 BLOAD "bib.m",IBINIT1
190 CALL IBINIT1 (IBFIND,IBTRG,IBCLR,IBPCT,IBSIC,IBLOC,IBPPC,IBBNA,IBONL,IBRSC,IBSRE,
IBRSV,IBPAD,IBSAD,IBIST,IBDMA,IBEOS,IBTMO,IBEOT,IBRDF,IBWRTF)
200 CALL IBINIT2 (IBGTS,IBCAC,IBWAIT,IBPOKE,IBWRT,IBWRTA,IBCMD,IBCMDA,IBRD,IBRDA,IBSTOP,
IBRPP,IBRSP,IBDIAG,IBXTRC,IBRDI,IBWRTI,IBRDIA,IBWRTIA,IBSTA%,IBERR%,IBCNT%)
210 REM
220 REM          IBM BASICA on IBM PC, PC-XT or PC-AT
230 REM
240 DEVNAME="I8842A"           'Device name is I8842A
250 CALL IBFIND (DEVNAME$,DVM%) 'Initialize the DMM
260 CALL IBCLR (DVM%)         'Clear device
270 FOR W = 1 TO 500: NEXT W   'Wait 1 second before sending commands
280 PRINT "MONITORING SELFTEST"
290 WRT$ = "Z0" : CALL IBWRT (DVM%,WRT$) 'Start selftest
300 WRT$ = "G7" : CALL IBWRT (DVM%,WRT$)
310 E$ = SPACES(6)
320 CALL IBRD (DVM%,E$)       'Read error status
330 IF (LEFT$(E$,4) = "1000") THEN GOTO 360 'Check for errors
340 WRT$ = "X0" : CALL IBWRT (DVM%,WRT$) 'Clear error register
350 PRINT "ERROR ";RIGHT$(E$,3);" OCCURRED" 'Print analog error
360 WRT$ = "G0" : CALL IBWRT (DVM%,WRT$) 'Get instrument configuration
370 ST$=SPACES(6)
380 CALL IBRD (DVM%,ST$)
390 IF LEFT$(ST$,4) >= "9000" THEN GOTO 300 'Check for selftest still active
400 WRT$ = "G7" : CALL IBWRT (DVM%,WRT$)
410 E$ = SPACES(6)
420 CALL IBRD (DVM%,E$)       'Read error status
430 IF (LEFT$(E$,4) = "1000") THEN GOTO 450 'Check for errors
440 PRINT "ERROR ";RIGHT$(E$,3);" OCCURRED" 'Print digital error
450 PRINT
460 PRINT "SELFTEST COMPLETE"
470 END

```

f3-14_03.wmf

Figure 3-14. Example Programs: Using the IBM PC (cont)

```

'
' The following application program is written in QBASIC for the IBM PC, PC-XT or
' PC-AT. The National Instruments Model GPIB-PCIIA board provides the interface
' between the PC and the Fluke 8842A DMM. The program assumes that the configuration
' program IBCONF has been run to initialize the interface board with the device
' name I8842A assigned to the GPIB0 board.
'
' This program selects VDC (F1), Autorange (R0), Slow rate (S0), Continuous trigger (T0)
' and suffixes enabled (Y1). The program takes 10 readings, displays them on the screen,
' and then stops.
'
' Microsoft QuickBasic V 4.5 on IBM PC, PC-XT or PC-AT

'$INCLUDE: 'qbib45.dcl'

devname$ = "I8842A"           'Device name is I8842A
CALL IBFIND(devname$, dvm%)  'Initialize the DMM
CALL IBCLR(dvm%)             'Clear device
WRT$ = "F1ROS0T0Y1"         'Set up command string
CALL IBWRT(dvm%, WRT$)      'Write functions to instrument
FOR i = 1 TO 10
    RD$ = SPACE$(18)         '11 characters for the reading, 5 for
                              'the suffix, and 2 for terminators
    CALL IBRD(dvm%, RD$)    'Get data
    PRINT i, LEFT$(RD$, 16) 'Print to display
NEXT i

END

```

Microsoft® is a registered trademark of Microsoft Corporation

QuickBASIC™ is a trademark of Microsoft Corporation

f3-14_04.wmf

Figure 3-14. Example Programs: Using the IBM PC (cont)

```

'
' The following application program is written in QBASIC for the IBM PC, PC-XT or
' PC-AT. The National Instruments Model GPIB-PCIIA board provides the interface
' between the PC and the Fluke 8842A DMM. The program assumes that the configuration
' program IBCONF has been run to initialize the interface board with the device
' name I8842A assigned to the GPIB0 board.
'
' This program selects VDC (F1), Autorange (R0), Slow rate (S0), Continuous trigger (T0)
' and suffixes enabled (Y1). All readings appear simultaneously on the instrument
' display and the PC screen with suffixes enabled for function readout. Full local
' control is given to the 8842A. Note the local control must be given to the board
' and not the device. Press <CTRL> BREAK to terminate this program.
'
' Microsoft QuickBasic V 4.5 on IBM PC, PC-XT or PC-AT

'$INCLUDE: 'qbib45.dcl'

BDNAME$ = "GPIB0"           'Board name is GPIB0
CALL IBFIND(BDNAME$, BD%)   'Initialize IEEE Interface Board
devname$ = "I8842A"        'Device name is I8842A
CALL IBFIND(devname$, dvm%) 'Initialize the device
CALL IBCLR(dvm%)           'Clear the device
WRT$ = "F1R0S0T0Y1"       'F1 = Volts DC, R0 = Autorange,
                           'S0 = Slow reading rate, T0 = Internal
                           'Trigger, Y1 = Enable suffix

CALL IBWRT(dvm%, WRT$)     'Write functions to the instrument
CALL IBLOC(dvm%)           'Give local control to the instrument
V% = 0: x% = 0
CALL IBSRE(BD%, V%)       'De-assert the remote enable (REN) signal so
                           'the 8842A stays in local when an IBRD call
                           'is made

again:

RD$ = SPACE$(18)          '11 characters for the reading, 5 for the
                           'suffix and 2 for the terminators

CALL IBRD(dvm%, RD$)      'Get data
x% = x% + 1               'Increment reading count
PRINT x%, LEFT$(RD$, 16)  'Display reading
GOTO again

END

```

f3-14_05.wmf

Figure 3-14. Example Programs: Using the IBM PC (cont)

```

'
' The following application program is written in QBASIC for the IBM PC, PC-XT or
' PC-AT. The National Instruments Model GPIB-PCIIA board provides the interface
' between the PC and the Fluke 8842A DMM. The program assumes that the configuration
' program IBCONF has been run to initialize the interface board with the device
' name I8842A assigned to the GPIB0 board.

'
' This program illustrates one possible use of the serial poll register. In this
' case it is merely looking for data available. The function of the program is to
' display on the screen the lowest resistance value measured on the input terminals
' of the 8842A using the 2-wire ohms function in autorange. The range and function
' commands are programmed using the Put Instrument Configuration (PO) command.

'
' Microsoft QuickBasic V 4.5 on IBM PC, PC-XT or PC-AT

'$INCLUDE: 'qbib45.dcl'

bdname$ = "GPIB0"           'Board name is GPIB0
CALL IBFIND(bdname$, BD%)  'Initialize the Interface Board
devname$ = "I8842A"        'Device name is I8842A
CALL IBFIND(devname$, dvm%) 'Initialize the device
CALL IBCLR(dvm%)           'Clear the device
WRT$ = "N3001P0 Y1 ?"      'Write functions to the instrument
CALL IBWRT(dvm%, WRT$)
RD$ = SPACE$(18)
CALL IBRD(dvm%, RD$)      'Get first reading
r = VAL(RD$)

label1:

PRINT LEFT$(RD$, 16); "S (2-WIRE) LOWEST READING"

DO                          'Execute the statements up to the loop
                             'statement until new low is found
    WRT$ = "?"
    CALL IBWRT(dvm%, WRT$)  'Trigger the device
    SPR% = 0
    DO UNTIL SPR% AND &H40 = &H40
        CALL IBRSP(dvm%, SPR%) 'Serial poll the device until data available
    LOOP
    RD$ = SPACE$(18)
    CALL IBRD(dvm%, RD$)    'Get next data
    s = VAL(RD$)

    LOOP WHILE s >= r      'Throw away data if not lowest

    r = s                  'Update lowest reading
    GOTO label1           'Print new low

END

```

f3-14_06.wmf

Figure 3-14. Example Programs: Using the IBM PC (cont)

```

'
' The following application program is written in QBASIC for the IBM PC, PC-XT or
' PC-AT. The National Instruments Model GPIB-PCIIA board provides the interface
' between the PC and the Fluke 8842A DMM. The program assumes that the configuration
' program IBCONF has been run to initialize the interface board with the device
' name I8842A assigned to the GPIBO board.
'
' This program illustrates a method of recording any errors produced by the 8842A
' selftest function. It should be noted that:
' 1. If more than one digital error occurs, only the last one will be reported.
' 2. The response to a Get Instrument Config. (G0) command during selftest is "9xxx".
' 3. The response to a Get Error Status (G7) command with no errors present is "1000".
'
' Microsoft QuickBasic V 4.5 on IBM PC, PC-XT or PC-AT

'$INCLUDE: 'qbib45.dcl'
BDNAME$ = "GPIBO" 'Board name is GPIBO
CALL IBFIND(BDNAME$, BD%) 'Initialize the interface board
devname$ = "I8842A" 'Device name is I8842A
CALL IBFIND(devname$, dvm%) 'Initialize the device
PRINT "MONITORING SELFTEST"
WRT$ = "Z0"
CALL IBWRT(dvm%, WRT$) 'Start selftest
DO
    WRT$ = "G7"
    CALL IBWRT(dvm%, WRT$)
    RD$ = SPACE$(18)
    CALL IBRD(dvm%, RD$) 'Get error status
    errcode$ = LEFT$(RD$, 4)
    IF (errcode$ <> "1000") THEN 'Check for errors
        WRT$ = "X0" 'Clear error register
        CALL IBWRT(dvm%, WRT$)
        PRINT "Error "; RIGHT$(errcode$, 3); " occurred"
    END IF
    CALL IBWRT(dvm%, "G0")
    st$ = SPACE$(16)
    CALL IBRD(dvm%, st$) 'Get instrument configuration
    stat$ = LEFT$(st$, 1)
LOOP WHILE stat$ = "9" 'Loop while selftest still active
WRT$ = "G7"
CALL IBWRT(dvm%, WRT$)
RD$ = SPACE$(18)
CALL IBRD(dvm%, RD$) 'Get error status
errcode$ = LEFT$(RD$, 4)
IF (errcode$ <> "1000") THEN 'Check for errors
    PRINT "Error"; RIGHT$(errcode$, 3); " occurred"
END IF
PRINT
PRINT "Selftest Complete"

END

```

f3-14_07.wmf

Figure 3-14. Example Programs: Using the IBM PC (cont)

```
/* The following application program is written in C for the IBM PC-AT. The National Instruments
Model AT-GPIB board provides the interface between the PC and the Fluke 8842A DMM. The
program assumes that the configuration program IBCONF has been run to initialize the interface
board with the device name I8842A assigned to the GPIB0 board.

This program selects VDC (F1), Autorange (R0), Slow rate (S0), Continuous trigger (T0) and suffixes
enabled (Y1). The program takes 10 readings, displays them on the screen, and then stops.

Microsoft C Version 6.0 on IBM PC-AT */

/* Link this program with appropriate mcib*.obj. */

#include <stdio.h>
#include "decl.h"

char rd[512]; /* read data buffer */
int dmm; /* device number */
int i;

main( )
{
dmm = ibfind("I8842A"); /* device name is I8842A */
ibclr(dmm); /* clear device */
ibwrt(dmm,"F1R0S0T0Y1",10); /* write functions to instrument */
for(i=0;i<10;i++)
{ibrd(dmm,rd); /* get data */
printf("%d %s",i,rd); /* print to display */
}
}
```

f3-14_08.wmf

Figure 3-14. Example Programs: Using the IBM PC (cont)

```

/* The following application program is written in C for the IBM PC-AT. The National Instruments
Model AT-GPIB board provides the interface between the PC and the Fluke 8842A DMM. The
program assumes that the configuration program IBCONF has been run to initialize the interface
board with the device name I8842A assigned to the GPIB0 board.

This program selects VDC (F1), Autorange (R0), Slow rate (S0), Continuous trigger (T0)
and suffixes enabled (Y1). All readings appear simultaneously on the instrument
display and the PC screen with suffixes enabled for function readout. Full local
control is given to the 8842A. Note the local control must be given to the board
and not the device. Press <CTRL> C to terminate this program.

Microsoft C Version 6.0 on IBM PC-AT */

/* Link this program with appropriate mcib*.obj. */

#include <stdio.h>
#include "decl.h"

char rd[512]; /* read data buffer */
int brd0; /* interface board number */
int dmm; /* device number */
int x;

main( )
{
brd0 = ibfind("GPIB0"); /* initialize board */
dmm = ibfind("I8842A"); /* initialize device */
ibclr(dmm); /* clear device */
ibwrt(dmm,"F1ROS0T0Y1",10); /* write functions to instrument */
ibloc(dmm); /* local the device */
ibsre(brd0,0); /* de-assert the remote enable (REN) signal so the */
/* 8842A stays in local when an ibrd call is made */

x = 0;

in:

ibrd(dmm,rd); /* get data */
x = x+1; /* increment reading count */
printf("%d %s",x,rd); /* display readings */
goto in;
}

```

f3-14_09.wmf

Figure 3-14. Example Programs: Using the IBM PC (cont)

```

/* The following application program is written in C for the IBM PC-AT. The National Instruments
Model AT-GPIB board provides the interface between the PC and the Fluke 8842A DMM. The
program assumes that the configuration program IBCONF has been run to initialize the interface
board with the device name I8842A assigned to the GPIBO board.

```

This program illustrates one possible use of the serial poll register. In this case it is merely looking for data available. The function of the program is to display on the screen the lowest resistance value measured on the input terminals of the 8842A using the 2-wire ohms function in autorange. The range and function commands are programmed using the Put Instrument Configuration (P0) command.

```

Microsoft C Version 6.0 on IBM PC-AT

```

```

*/

```

```

/* Link this program with appropriate mcib*.obj.

```

```

*/

```

```

#include <stdio.h>
#include "decl.h"
#include <string.h>
#include <math.h>

```

```

char rd[512];          /* read data buffer          */
int brd0;             /* interface board number   */
int dmm;              /* device number            */
char spr;             /* serial poll response byte */
float r,s;
char rd_string[11],ss[11];

```

```

main( )

```

```

{
    brd0 = ibfind( "GPIBO" );          /* initialize interface board */
    dmm = ibfind( "I8842A" );         /* initialize 8842A           */
    ibclr( dmm );                      /* clear device                */
    ibwrt( dmm, "N3001POY1?", 10);    /* write functions to instrument */
    ibrd(dmm,rd,16);                  /* get data                    */
    strncpy(rd_string,rd,11);
    r=atof(rd_string);                /* convert from string to floating point */

```

```

label1: printf("%sS (2-wire) LOWEST READING\r\n",rd);

```

```

    do {
        ibwrt(dmm,"?",1);             /* trigger the device         */
        do
            ibrsp(dmm,spr);           /* serial poll the device     */
        while (spr & 0x40 != 0x40);   /* until data available      */
        ibrd(dmm,rd,16);              /* get next data             */
        s=atof(rd);                   /* convert to floating point  */
        printf("\r");
    }
    while (s>=r);                      /* throw away data if not lowest */
    r=s;
    goto label1;                       /* print new low             */
}

```

f3-14_10.wmf

Figure 3-14. Example Programs: Using the IBM PC (cont)

```

/* The following application program is written in C for the IBM PC-AT. The National Instruments
Model AT-GPIB board provides the interface between the PC and the Fluke 8842A DMM. The
program assumes that the configuration program IBCONF has been run to initialize the interface
board with the device name I8842A assigned to the GPIB0 board.

This program illustrates a method of recording any errors produced by the 8842A selftest function.
It should be noted that:
1. If more than one digital error occurs, only the last one will be reported.
2. The response to a Get Instrument Config. (G0) command during selftest is "9xxx".
3. The response to a Get Error Status (G7) command with no errors present is "1000".

Microsoft C Version 6.0 on IBM PC-AT */

/* Link this program with appropriate mcib*.obj. */

#include <stdio.h>
#include "decl.h"
#include <string.h>

char rd[512]; /* read data buffer */
int brd0; /* interface board number */
int dmm; /* device number */
char selftest_active[1]; /* selftest active flag */
char errcode[4]; /* error code buffer */

main( )
{
brd0 = ibfind("GPIB0"); /* initialize interface board */
dmm = ibfind("I8842A"); /* initialize 8842A */
ibclr(dmm); /* clear device */
ibwrt(dmm,"Z0",2); /* start 8842A self test */
do{ /* do while self test active */
    ibwrt(dmm,"G7",2); /* get error status */
    ibrd(dmm,rd,16);
    strncpy(errcode,rd,4);
    if (strcmp(errcode,"1000")!=0) /* test for error */
        {ibwrt(dmm,"X0",2);
        printf("Error %s occurred\r\n",errcode);
        }
    ibwrt(dmm,"G0",2); /* get instrument configuration */
    ibrd(dmm,rd,16);
    strncpy(selftest_active,rd,1);
}
while (strcmp(selftest_active,"9")==0); /* check for self test active */
ibwrt(dmm,"G7",2); /* get error status */
ibrd(dmm,rd,16);
strncpy(errcode,rd,4);
if (strcmp(errcode,"1000")!=0) /* test for last digital error */
    printf("Error %s occurred\r\n",errcode);
printf("\r\nSelftest complete\r\n");
}

```

f3-14_11.wmf

Figure 3-14. Example Programs: Using the IBM PC (cont)

Table 3-4. ASCII/IEEE Std 488-1978 Bus Codes

ASCII CHAR.	DECIMAL	OCTAL	HEX	BINARY 7654 3210	DEV. NO.	MESSAGE ATN=TRUE	
NUL	0	000	00	0000 0000			ADDRESSED COMMANDS
SOH	1	001	01	0000 0001		GTL	
STX	2	002	02	0000 0010			
ETX	3	003	03	0000 0011			
EOT	4	004	04	0000 0100		SDC	
ENQ	5	005	05	0000 0101		PPC	
ACK	6	006	06	0000 0110			
BELL	7	007	07	0000 0111			
BS	8	010	08	0000 1000		GET	
HT	9	011	09	0000 1001		TCT	
LF	10	012	0A	0000 1010			
VT	11	013	0B	0000 1011			
FF	12	014	0C	0000 1100			
CR	13	015	0D	0000 1101			
SO	14	016	0E	0000 1110			
SI	15	017	0F	0000 1111			
DLE	16	020	10	0001 0000		LLO	
DC1	17	021	11	0001 0001			
DC2	18	022	12	0001 0010			
DC3	19	023	13	0001 0011			
DC4	20	024	14	0001 0100		DCL	
NAK	21	025	15	0001 0101			
SYN	22	026	16	0001 0110			
ETB	23	027	17	0001 0111			
CAN	24	030	18	0001 1000		SPE	
EM	25	031	19	0001 1001			
SUB	26	032	1A	0001 1010			
ESC	27	033	1B	0001 1011			
FS	28	034	1C	0001 1100			
GS	29	035	1D	0001 1101			
RS	30	036	1E	0001 1110			
US	31	037	1F	0001 1111			
SPACE	32	040	20	0010 0000	0	MLA	LISTEN ADDRESSES
!	33	041	21	0010 0001	1	MLA	
"	34	042	22	0010 0010	2	MLA	
#	35	043	23	0010 0011	3	MLA	
\$	36	044	24	0010 0100	4	MLA	
%	37	045	25	0010 0101	5	MLA	
&	38	046	26	0010 0110	6	MLA	
'	39	047	27	0010 0111	7	MLA	
(40	050	28	0010 1000	8	MLA	
)	41	051	29	0010 1001	9	MLA	
*	42	052	2A	0010 1010	10	MLA	
+	43	053	2B	0010 1011	11	MLA	
,	44	054	2C	0010 1100	12	MLA	
-	45	055	2D	0010 1101	13	MLA	
.	46	056	2E	0010 1110	14	MLA	
/	47	057	2F	0010 1111	15	MLA	
0	48	060	30	0011 0000	16	MLA	
1	49	061	31	0011 0001	17	MLA	
2	50	062	32	0011 0010	18	MLA	
3	51	063	33	0011 0011	19	MLA	
4	52	064	34	0011 0100	20	MLA	
5	53	065	35	0011 0101	21	MLA	
6	54	066	36	0011 0110	22	MLA	
7	55	067	37	0011 0111	23	MLA	
8	56	070	38	0011 1000	24	MLA	
9	57	071	39	0011 1001	25	MLA	
:	58	072	3A	0011 1010	26	MLA	
;	59	073	3B	0011 1011	27	MLA	
<	60	074	3C	0011 1100	28	MLA	
=	61	075	3D	0011 1101	29	MLA	
>	62	076	3E	0011 1110	30	MLA	
?	63	077	3F	0011 1111		UNL	
{	64	100	40	0100 0000	0	MTA	TALK ADDRESSES
A	65	101	41	0100 0001	1	MTA	
B	66	102	42	0100 0010	2	MTA	
C	67	103	43	0100 0011	3	MTA	
D	68	104	44	0100 0100	4	MTA	
E	69	105	45	0100 0101	5	MTA	
F	70	106	46	0100 0110	6	MTA	
G	71	107	47	0100 0111	7	MTA	
H	72	110	48	0100 1000	8	MTA	
I	73	111	49	0100 1001	9	MTA	
J	74	112	4A	0100 1010	10	MTA	
K	75	113	4B	0100 1011	11	MTA	
L	76	114	4C	0100 1100	12	MTA	
M	77	115	4D	0100 1101	13	MTA	
N	78	116	4E	0100 1110	14	MTA	
O	79	117	4F	0100 1111	15	MTA	
P	80	120	50	0101 0000	16	MTA	
Q	81	121	51	0101 0001	17	MTA	
R	82	122	52	0101 0010	18	MTA	
S	83	123	53	0101 0011	19	MTA	
T	84	124	54	0101 0100	20	MTA	
U	85	125	55	0101 0101	21	MTA	
V	86	126	56	0101 0110	22	MTA	
W	87	127	57	0101 0111	23	MTA	
X	88	130	58	0101 1000	24	MTA	
Y	89	131	59	0101 1001	25	MTA	
Z	90	132	5A	0101 1010	26	MTA	
[91	133	5B	0101 1011	27	MTA	
\	92	134	5C	0101 1100	28	MTA	
]	93	135	5D	0101 1101	29	MTA	
^	94	136	5E	0101 1110	30	MTA	
_	95	137	5F	0101 1111		UNT	
a	96	140	60	0110 0000	0	MSA	SECONDARY ADDRESSES
b	97	141	61	0110 0001	1	MSA	
c	98	142	62	0110 0010	2	MSA	
d	99	143	63	0110 0011	3	MSA	
e	100	144	64	0110 0100	4	MSA	
f	101	145	65	0110 0101	5	MSA	
g	102	146	66	0110 0110	6	MSA	
h	103	147	67	0110 0111	7	MSA	
i	104	150	68	0110 1000	8	MSA	
j	105	151	69	0110 1001	9	MSA	
k	106	152	6A	0110 1010	10	MSA	
l	107	153	6B	0110 1011	11	MSA	
m	108	154	6C	0110 1100	12	MSA	
n	109	155	6D	0110 1101	13	MSA	
o	110	156	6E	0110 1110	14	MSA	
p	111	157	6F	0110 1111	15	MSA	
q	112	160	70	0111 0000	16	MSA	
r	113	161	71	0111 0001	17	MSA	
s	114	162	72	0111 0010	18	MSA	
t	115	163	73	0111 0011	19	MSA	
u	116	164	74	0111 0100	20	MSA	
v	117	165	75	0111 0101	21	MSA	
w	118	166	76	0111 0110	22	MSA	
x	119	167	77	0111 0111	23	MSA	
y	120	170	78	0111 1000	24	MSA	
z	121	171	79	0111 1001	25	MSA	
{	122	172	7A	0111 1010	26	MSA	
	123	173	7B	0111 1011	27	MSA	
]	124	174	7C	0111 1100	28	MSA	
^	125	175	7D	0111 1101	29	MSA	
_	126	176	7E	0111 1110	30	MSA	
?	127	177	7F	0111 1111		MSA	

NOTE

For the examples using the Fluke 1720A or 1722A, the 8842A is plugged into port 0. The port is initialized by the INIT statement, which sends IFC (interface clear).

Chapter 4

Measurement Tutorial

	Title	Page
4-1.	INTRODUCTION	4-2
4-2.	DC VOLTAGE MEASUREMENT	4-2
4-3.	Circuit Loading Error	4-2
4-4.	Input Bias Current Error	4-3
4-5.	RESISTANCE MEASUREMENT	4-4
4-6.	2-Wire Ohms	4-4
4-7.	Correcting for Test Lead Resistance in 2-Wire Ohms	4-5
4-8.	4-Wire Ohms	4-5
4-9.	Applications of the Ohms Functions	4-7
4-10.	TESTING DIODES	4-7
4-11.	TESTING ELECTROLYTIC CAPACITORS	4-7
4-12.	A PRECISION CURRENT SOURCE	4-8
4-13.	DC CURRENT MEASUREMENT	4-8
4-14.	REDUCING THERMAL VOLTAGES	4-9
4-15.	AC VOLTAGE AND CURRENT MEASUREMENT	4-10
4-16.	True RMS Measurement	4-10
4-17.	Waveform Comparison	4-10
4-18.	Crest Factor	4-12
4-19.	AC-Coupled AC Measurements	4-12
4-20.	Combined AC and DC Measurements	4-13
4-21.	Bandwidth	4-13
4-22.	Zero-Input VAC Error	4-13
4-23.	MAKING ACCURATE MEASUREMENTS ON THE 20 mV AND 20 Ω RANGES	4-14
4-24.	MAKING ACCURATE HIGH-RESISTANCE MEASUREMENTS	4-15

4-1. INTRODUCTION

This section discusses considerations and techniques to help you use the 8842A effectively. Among other things, this section discusses sources of error which are an inherent part of the measurement process and which occur for all multimeters. By understanding why and when these errors occur, and by knowing how and when to correct for them, you can make accurate measurements with confidence.

This section also discusses the relative benefits of 2-wire and 4-wire ohms, describes special considerations for making ac measurements, and presents some unusual applications--for example, using the test current in the 2-wire ohms function as a troubleshooting tool in itself.

4-2. DC VOLTAGE MEASUREMENT

When measuring dc voltages in high-impedance circuits, there are two possible sources of error to consider: circuit loading and input bias current.

4-3. Circuit Loading Error

Whenever a voltmeter is connected to a circuit, the voltmeter's internal resistance changes the voltage of the circuit under test. The resulting error is called circuit loading error. The error is negligible as long as the resistance of the circuit under test (the source impedance) is small compared to the input impedance of the meter. As the source impedance approaches the input impedance of the voltmeter, the error can be considerable. The percentage of error can be calculated using the formula in Figure 4-1.

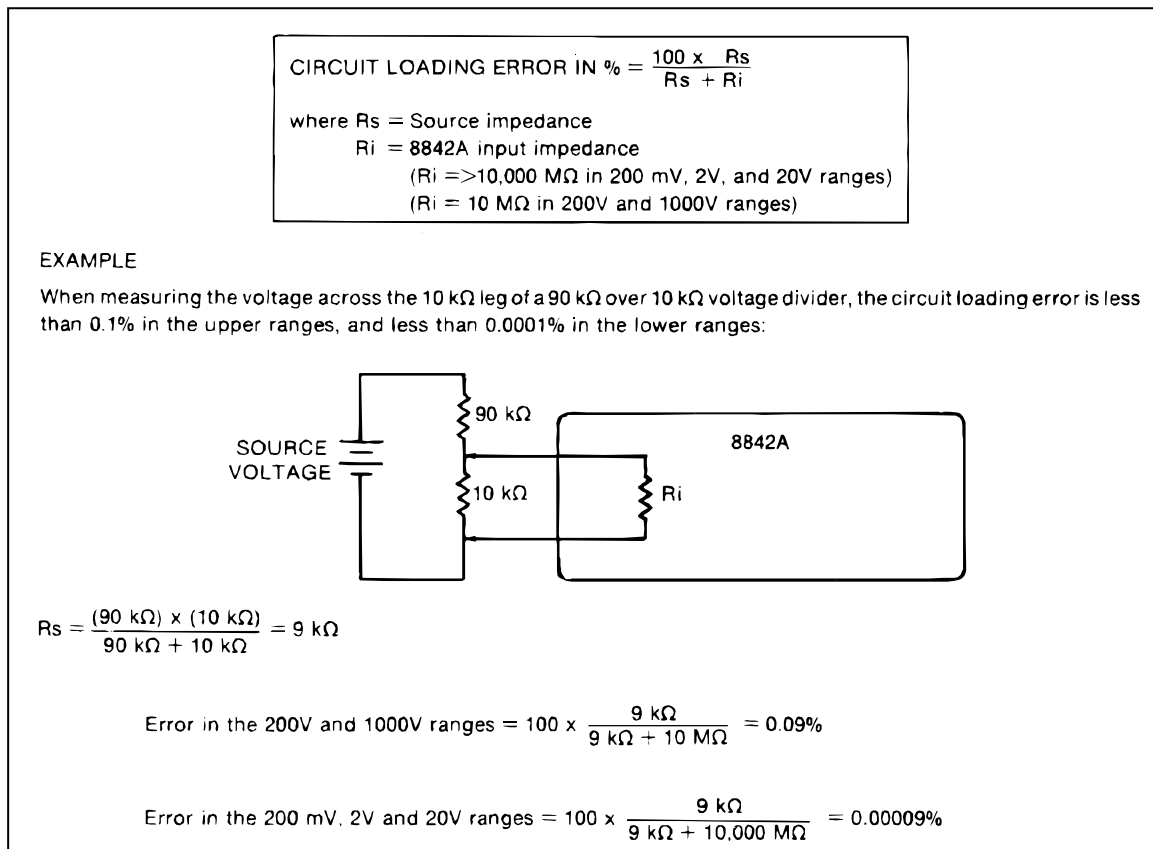

Figure 4-1. Circuit Loading Error Calculation

f4-01.wmf

The input impedance of the 8842A is 10 MΩ in the 200V and 1000V dc ranges, and is greater than 10,000 MΩ in the 20 mV, 200 mV, 2V, and 20V ranges. Therefore, for the 8842A, circuit loading error is less than 0.01% as long as the source impedance is less than 1 MΩ in the 20 mV, 200 mV, 2V, and 20V ranges, and less than 1 kΩ in the 200V and 1000V ranges. The exceptionally high input impedance on the 20V dc range allows high-accuracy readings in CMOS and high-impedance analog circuitry.

NOTE

Input protection circuitry can reduce the input impedance to as low as 100 kΩ when the input is overrange. This may also occur momentarily when the instrument autoranges to a higher range.

4-4. Input Bias Current Error

Input bias current error occurs because a voltmeter's input bias current always changes the voltage of the circuit under test. However, the error is significant only when measuring voltages in circuits with very high source impedance. The error can be measured as shown in Figure 4-2.

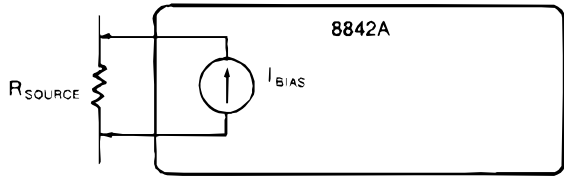

TO MEASURE INPUT BIAS CURRENT ERROR:

1. Select the VDC function and the desired range.
2. Eliminate any offset voltages by shorting the HI INPUT and LO INPUT terminals and then pressing OFFSET.
3. Select a resistor which matches the source impedance (R_{SOURCE}) of the circuit to be tested, and connect it to the HI INPUT and LO INPUT terminals.
4. Allow the circuit to settle.
5. Record the displayed voltage. This is the input bias current error (V_{ERROR}).

The input bias current error may be calculated as a percentage as follows:

$$ERROR \text{ (IN \%)} = \frac{V_{ERROR}}{VOLTAGE \text{ MEASUREMENT}} \times 100\%$$

The input bias current itself (I_{BIAS}) may be calculated as follows:

$$I_{BIAS} = \frac{V_{ERROR}}{R_{SOURCE}}$$

Figure 4-2. Measuring Input Bias Current Error

f4-02.wmf

With the 8842A, it is easy to correct for this error using the OFFSET button:

1. Select the VDC function and the desired range.
2. Connect the 8842A INPUT terminals to a resistor which matches the source impedance of the circuit to be tested.

3. Allow the displayed reading to settle.
4. Press the OFFSET button.
5. Remove the resistor.
6. Proceed with the desired measurement.

Example:

Measure a 1.5V source with 1 M Ω source impedance, correcting for input bias current.

1. Connect a 1 M Ω resistor between the INPUT HI and INPUT LO terminals.
2. Select the VDC function and the 2V range.
3. Allow the display to settle.
4. Press OFFSET. (This zeroes the input bias current error.)
5. Remove the 1 M Ω resistor.
6. Measure the voltage of the circuit under test.

Note that this procedure does not correct for circuit loading error. Also note that if input bias current error is not corrected for, it may be added to the circuit loading error.

4-5. RESISTANCE MEASUREMENT

The 8842A allows you to measure resistance in both 2-wire and 4-wire configurations. Each has its benefits.

4-6. 2-Wire Ohms

Two-Wire ohms measurements are simple to set up and yield good results for most measurement conditions. Measurements are made as shown in Figure 4-3. An internal current source (the "ohms current source") passes a known test current (I_{test}) through the resistance being tested ($R_{unknown}$). The 8842A measures the voltage drop across $R_{unknown}$, calculates $R_{unknown}$ using Ohm's law ($R_{unknown} = V_{test}/I_{test}$), and displays the result.

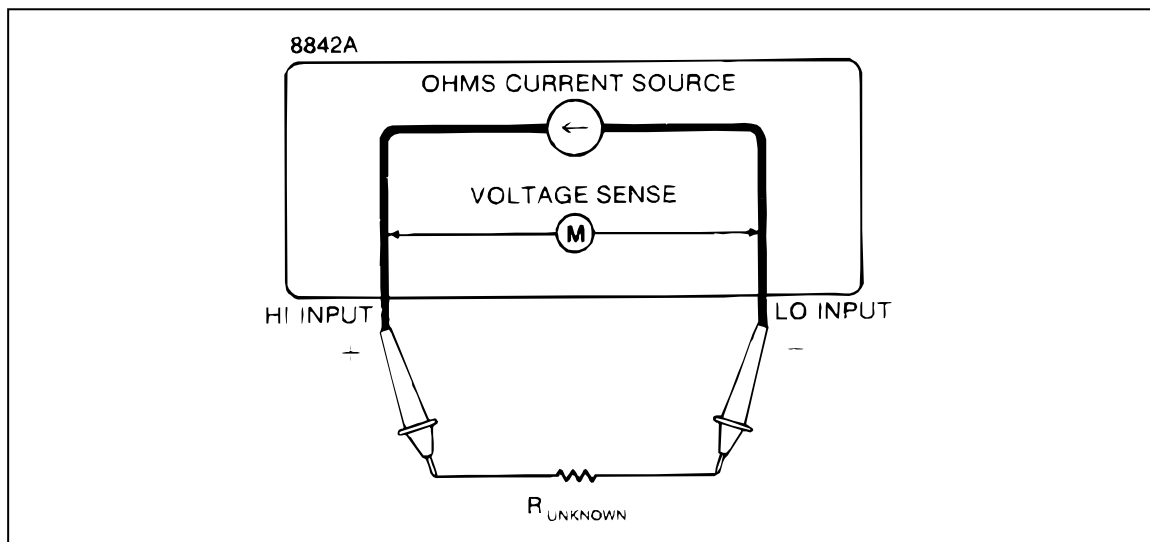

Figure 4-3. Wire Ohms Measurement

f4-03.wmf

The test current and full-scale voltage for each resistance range are shown in Table 4-1. Since the HI INPUT test lead is positive with respect to the LO INPUT lead, these test leads are not interchangeable when a semiconductor device is being measured.

4-7. Correcting for Test Lead Resistance in 2-Wire Ohms

In 2-wire ohms, the resistance of the test leads can introduce error when measuring low resistances. Typical test leads may add as much as 0.5Ω to 2-wire ohms readings.

With the 8842A, it is easy to correct for this error using the OFFSET button:

1. Select the 2-wire ohms function.
2. Touch the test leads together. The 8842A should indicate the resistance of the test leads.
3. With the test leads still touching, press the OFFSET button. The 8842A should read 0Ω .

4-8. 4-Wire Ohms

Four-Wire ohms measurements provide the highest accuracy for low resistance measurements. The 4-wire configuration automatically corrects for both test lead resistance and contact resistance. Contact resistance (the resistance between the test probe tips and the circuit being tested) is unpredictable, and therefore cannot be reliably corrected with a fixed offset.

Four-Wire ohms measurements are especially important when using long test leads. In a typical automated test system, for example, the test leads could be connected through four or five switching relays, each with 2Ω of resistance!

NOTE

Instability of the test lead's resistance can cause significant error on low ohms ranges, particularly on the 20Ω and 200Ω ranges. Therefore, only 4-wire ohms measurement is permitted in the 20Ω range.

The 8842A makes 4-wire ohms measurements as shown in Figure 4-4. The HI and LO INPUT leads apply a known, internal current source to the unknown resistance, just as in 2-wire ohms. (See Table 4-1.) However, the voltage drop across the unknown resistance is measured with the SENSE leads rather than the INPUT leads. Since the current flow in the SENSE leads is negligible, the error caused by the voltage drop across the leads is also negligible.

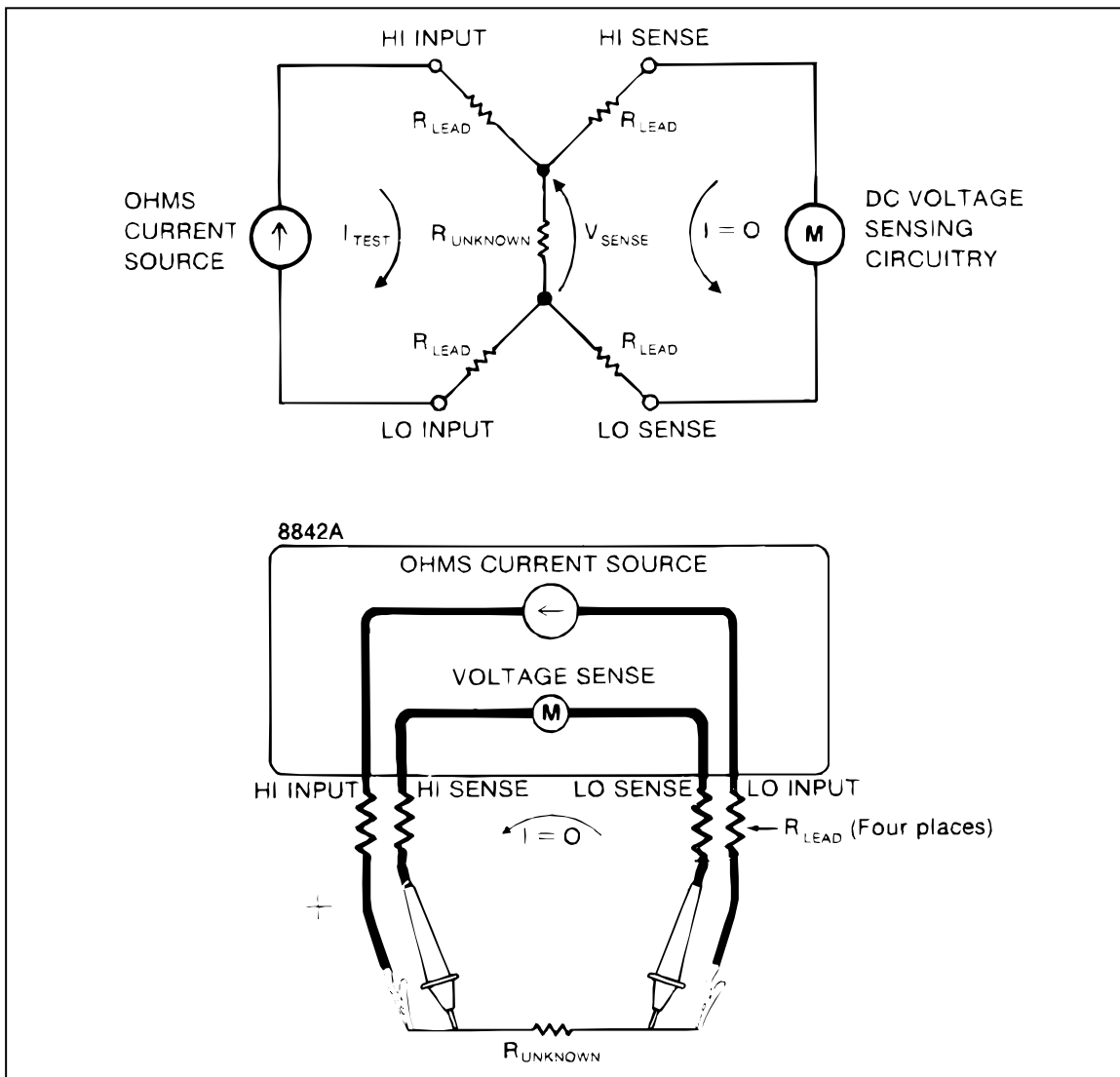

f4-04.wmf

Figure 4-4. Wire Ohms Measurement

Table 4-1. Ohms Test Current

RANGE	TEST CURRENT	FULL SCALE VOLTAGE
20Ω	1 mA	0.02V
200Ω	1 mA	0.2V
2 kΩ	1 mA	2.0V
20 kΩ	100 μA	2.0V
200 kΩ	10 μA	2.0V
2000 kΩ	5 μA	10.0V
20 MΩ	500 nA	10.0V

NOTE

In the 2 M Ω and 20 M Ω ranges of 4-wire ohms, the voltage across the unknown resistance is sensed between the HI SENSE and LO INPUT terminals. Accuracy is not affected as long as the resistance of the LO INPUT lead is less than 10 Ω in the 2 M Ω range, and less than 100 Ω in the 20 M Ω range.

4-9. Applications of the Ohms Functions

The 2-wire and 4-wire ohms functions can be used for a variety of purposes in addition to measuring resistance, as the following applications show.

4-10. TESTING DIODES

The 2-wire ohms function can also be used to test diodes.

1. Select the 2-wire ohms function and the 2 k Ω range.
2. Measure the resistance of the diode. If the diode is good, when forward-biased it will measure about 0.6 k Ω to 0.7 k Ω for silicon (0.25 k Ω to 0.3 k Ω for germanium), and when reverse-biased it will cause the 8842A to indicate overrange. (The forward-biased reading depends upon the range used.)

The 2 k Ω range is used because its 1 mA test current provides a typical operating point, and its 2V full-scale voltage is sufficient to turn on most diodes (even two diodes in series).

4-11. TESTING ELECTROLYTIC CAPACITORS

The 2-wire ohms function can also give a rough test of an electrolytic capacitor's leakage and dielectric absorption. This test works well for capacitors 0.5 μ F and larger.

1. Select the 2-wire ohms function, the 2 k Ω range, and the medium reading rate.
2. Connect the test leads to the capacitor (with the INPUT HI lead to the + lead and the INPUT LO lead to the - lead). The 8842A attempts to charge it to the open-circuit voltage of the 2 k Ω range (about 6V).
3. Disconnect the + test lead.
4. To test for leakage, select the VDC function and the 20V range (leave the 8842A in the medium reading rate), and measure the voltage that was stored on the capacitor during step 2.
 - a. If the capacitor is good, the voltage across the capacitor will be about 6V, and will be relatively stable.
 - b. If the capacitor is leaky, the voltage across the capacitor will be much less than 6V, and the voltage will be decreasing. The rate of change depends on how leaky the capacitor is.
 - c. With some electrolytic capacitors, the reading will increase. This usually indicates the capacitor is defective.
5. To test the capacitor's dielectric absorption, briefly short the capacitor's leads together and then measure the voltage across the capacitor.
 - a. If the dielectric is good (i.e., has low dielectric absorption), the voltage across the capacitor will be nearly zero volts.
 - b. If the dielectric is poor (i.e., has high dielectric absorption), the voltage across the capacitor will be significantly above zero.

4-12. A PRECISION CURRENT SOURCE

The ohms current source (the internal current source used in the ohms functions) makes a useful troubleshooting tool in itself. It has excellent linearity and temperature stability. Its compliance voltage is typically 5V in the lower five ohms ranges, and 12V in the upper two ohms ranges. The inputs are protected against accidental applications of voltage up to 300V rms.

To use the ohms current source, connect the test leads to the HI and LO INPUTS, and select either the 2-wire or 4-wire ohms function. Press the range buttons to select any of the current levels shown in Table 4-1.

The ohms current source can be used to troubleshoot circuits by injecting current into selected nodes, forcing the circuits to be in a specific test state. For example, the ohms current source can be used to set or modify the bias of amplifier circuits. The current level can be changed simply by changing range.

The ohms current source can also be used to test mA or μ A panel meters. The accuracy of the current source is more than enough to verify panel meters, whose accuracy is typically 1% to 5%. To test an analog panel meter, simply connect the current source across the meter movement (as though measuring its resistance). A 1 mA meter should show full scale when the ohms function is set on the 2 k Ω range. The same technique also works with digital panel meters.

4-13. DC CURRENT MEASUREMENT

To get the best accuracy using the mA DC function, it is important to understand the concept of burden voltage error.

When a meter is placed in series with a circuit to measure current, error can be caused by the small voltage drop across the meter (in this case, across the protective fuses and current shunt). This voltage drop is called the burden voltage, and it is highest for full-scale measurements. The full-scale burden voltage for the 8842A is typically less than 1V.

The burden voltage can present a significant error if the current source being measured is unregulated (i.e., not a true current source) and if the resistance of the fuse and shunt is a significant part of the source resistance. If burden voltage does present a significant error, the percentage of error can be calculated and corrected for using the formulas in Figure 4-5.

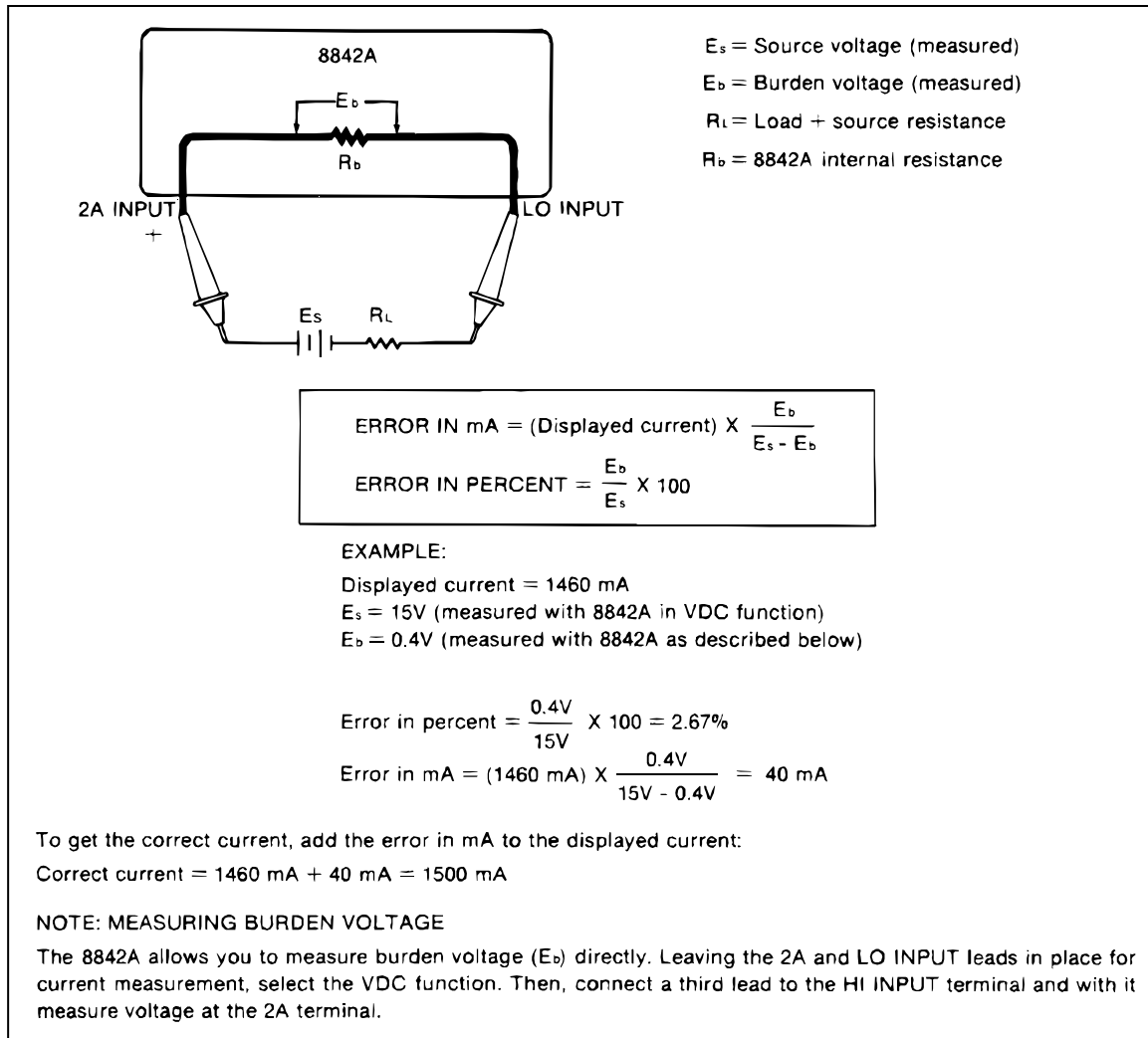

Figure 4-5. Burden Voltage Error Calculation

f4-05.wmf

4-14. REDUCING THERMAL VOLTAGES

When making very low-level dc measurements, thermal voltages can present an additional source of error. Thermal voltages are the thermovoltic potentials generated at the junction between dissimilar metals. Thermal voltages typically occur at binding posts and can be greater than 10 μ V.

Thermal voltages can also cause problems in the low dc and ohms ranges, particularly in the 20 mV and 20 Ω ranges. Some low-value resistors are constructed with dissimilar metals. Just handling such resistors can cause thermal voltages large enough to introduce measurement errors.

The effect of thermal voltages can be reduced by using the following techniques:

1. Use tight connections.
2. Use clean connections (especially free of grease and dirt).
3. Use similar metals for connections wherever possible (e.g., copper-to-copper, gold-to-gold, etc.).

4. Use caution when handling the circuit under test.
5. Wait for the circuit to reach thermal equilibrium. (Thermal voltages are generated only where there is a temperature gradient.)

4-15. AC VOLTAGE AND CURRENT MEASUREMENT

When making precise measurements of ac voltage and current, there are several considerations in addition to those discussed under dc voltage and current measurement. These include the concepts of rms conversion, crest factor, bandwidth, and zero-input error.

4-16. True RMS Measurement







The True RMS AC Option measures the true rms value of ac voltages and currents. In physical terms, the rms (root-mean-square) value of a waveform is the equivalent dc value that causes the same amount of heat to be dissipated in a resistor. True rms measurement greatly simplifies the analysis of complex ac signals. Since the rms value is the dc equivalent of the original waveform, it provides a reliable basis for comparing dissimilar waveforms.

By contrast, many meters in use today use average-responding ac converters rather than true rms converters. The scale factor in these meters is adjusted so that they display the rms value for harmonic-free sinusoids. However, if a signal is not sinusoidal, average-responding meters do not display correct rms readings.

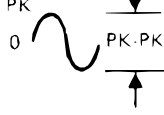
The 8842A actually derives the rms value using analog computation. This means that the 8842A readings represent true rms values not only for harmonic-free sinusoids, but also for mixed frequencies, modulated signals, square waves, sawtooths, random noise, rectangular pulses with 10% duty cycle, etc.

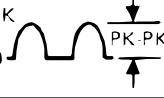
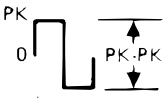
4-17. Waveform Comparison

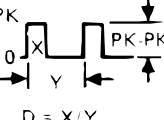
Figure 4-6 illustrates the relationship between ac and dc components for common waveforms, and compares readings for true rms meters and average-responding meters. For example, consider the first waveform, a 1.41421V (zero-to-peak) sine wave. Both the 8842A and rms-calibrated average-responding meters display the correct rms reading of 1.00000V (the dc component equals 0). However, consider the 2V (peak-to-peak) square wave. Both types of meter correctly measure the dc component (0V), but only the 8842A correctly measures the ac component (1.00000V). The average-responding meter measures 1.110V, which amounts to an 11% error.

AC-COUPLED INPUT WAVEFORM	PEAK VOLTAGES		METERED VOLTAGES			DC AND AC TOTAL RMS
	PK-PK	0-PK	AC COMPONENT ONLY		DC COMPONENT ONLY	
			RMS CAL*	8842A		TRUE RMS = $\sqrt{v_{ac}^2 + dc^2}$
SINE 	2.828	1.414	1.000	1.000	0.000	1.000
RECTIFIED SINE (FULL WAVE) 	1.414	1.414	0.421	0.435	0.900	1.000
RECTIFIED SINE (HALF WAVE) 	2.000	2.000	0.764	0.771	0.636	1.000
SQUARE 	2.000	1.000	1.110	1.000	0.000	1.000
RECTIFIED SQUARE 	1.414	1.414	0.785	0.707	0.707	1.000
RECTANGULAR PULSE  $D = X \cdot Y$ $K = \sqrt{D - D^2}$	2.000	2.000	2.22K	2K	2D	$2\sqrt{D}$
TRIANGLE SAWTOOTH 	3.464	1.732	0.960	1.000	0.000	1.000
* RMS CAL IS THE DISPLAYED VALUE FOR AVERAGE RESPONDING METERS THAT ARE CALIBRATED TO DISPLAY RMS FOR SINE WAVES						









f4-06.wmf

Figure 4-6. Waveform Comparison Chart

Since average-responding meters have been in use for so long, you may have accumulated test or reference data based on them. The conversion factors in Figure 4-6 should help you convert between the two measurement methods.

4-18. Crest Factor

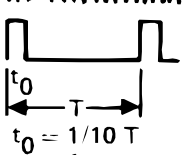
Crest factors are useful for expressing the ability of an instrument to measure a variety of waveforms accurately. The crest factor of a waveform is the ratio of its peak voltage to its rms voltage. (For waveforms where the positive and negative half-cycles have different peak voltages, the more extreme peak is used in computing the crest factor.) Crest factors start at 1.0 for square waves (for which the peak voltage equals the rms voltage) and increase for more "pointed" waveforms as shown in Figure 4-7.

WAVEFORM	CREST FACTOR
SQUARE WAVE 	1.0
SINE WAVE 	1.414
TRIANGLE SAWTOOTH 	1.732
MIXED FREQUENCIES 	1.414 to 2.0
SCR OUTPUT OF 100% - 10% 	1.414 to 3.0
WHITE NOISE 	3.0 to 4.0
AC COUPLED PULSE TRAIN 	3.0
SPIKE 	> 9.0

f4-07.wmf

Figure 4-7. Typical Crest Factors for Various Waveforms

The 8842A has a full-scale crest factor limit of 3.0 for the 20V and 700V ranges, and 6.0 for the other ranges. For full-scale input signals with a crest factor above these limits, dynamic range limitations can begin to cause large errors. However, as Figure 4-7 shows, signals with a crest factor above 3.0 are unusual.

If you don't know the crest factor of a particular waveform but wish to know if it falls within the crest factor limit of the 8842A, measure the signal with both the 8842A and an ac-coupled oscilloscope. If the rms reading on the 8842A is 1/3 or more of the waveform's zero-to-peak voltage, the crest factor is 3.0 or less.

4-19. AC-Coupled AC Measurements

Input signals are ac-coupled in the ac functions. One of the advantages of ac coupling is that ac measurements can be made on power supply outputs, phone lines, etc. Ripple

measurements, for instance, cannot be made with dc coupling. Remember, however, that when the 8842A measures signals with the ac functions, the reading on the display does not include the dc component (if one exists). For example, consider Figure 4-8, which shows a simple ac signal riding on a dc level. The VAC function would measure the ac component only.

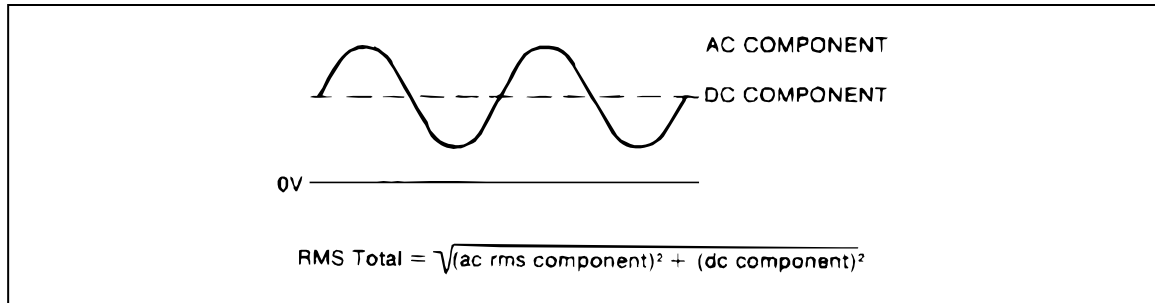

f4-08.wmf

Figure 4-8. Combined AC and DC Measurement

4-20. Combined AC and DC Measurements

The 8842A can be used to evaluate the true rms value of waveforms such as the one shown in Figure 4-8, which includes both ac and dc components. First, measure the rms value of the ac component using the VAC function. Next, measure the dc component using the VDC function. Finally, calculate the total rms value as follows:

$$V_{\text{RMS}} = \sqrt{V_{\text{AC}}^2 + V_{\text{DC}}^2}$$

4-21. Bandwidth

Bandwidth defines the range of frequencies to which an instrument can respond accurately. The accuracy of the 8842A is specified for sinusoidal waveforms up to 100 kHz, or for nonsinusoidal waveforms with frequency components up to 100 kHz. The small-signal bandwidth (the frequency at which the response is 3 dB down) is typically around 300 kHz.

For signals with components greater than 100 kHz, the measurement accuracy is reduced because of frequency bandwidth and slew-rate limitations. Because of this, accuracy may be reduced when measuring signals with fast rise times, such as high-frequency square waves or switching supply waveforms. As a rule of thumb, an ac voltage input signal is within the bandwidth limitations if the rise time is longer than 2 μs , and within the slew-rate limitations if the input slew rate is slower than $(1\text{V}/\mu\text{s}) \times (\text{full scale of range})$.

4-22. Zero-Input VAC Error

If the 8842A input terminals are shorted while the VAC function is selected, the 8842A displays a non-zero reading (typically less than 80 digits in the highest four ranges, and less than 300 digits in the 200 mV range). Such readings are due to random noise combined with the inherent nonlinear response of computing-type rms converters to very small input signals.

The zero-input error is quickly reduced when the input is increased. The rms converter error (a dc error) and the internally generated noise (a random ac error) are both uncorrelated with the input signal. Therefore, when a signal is applied, the resulting reading is not the simple addition of the signal and the zero-input error, but the square root of the sum of their squares. This reduces the effect of the error, as shown in the example in Figure 4-9.

EXAMPLE

Given a zero-input reading of 300 counts (0.300 mV in the 200 mV range) and an input signal of 10 mV, the 8842A might read:

$$\sqrt{10^2 + 0.300^2} = \sqrt{100 + 0.090} = 10.004 \text{ mV}$$

The effect of the zero-input error is reduced from 0.300 mV to 0.004 mV.

f4-09.wmf

Figure 4-9. Reduction of Zero-Input Error

As long as the 8842A reading is 1,000 counts or more, readings will still be within specified accuracy.

4-23. MAKING ACCURATE MEASUREMENTS ON THE 20 mV AND 20Ω RANGES

NOTE

When making low-level (uV) measurements after a large step signal has been applied to the inputs, allow sufficient time for thermal emfs and other system-related sources of error to settle before taking readings.

The 20 mV dc and 20Ω ranges are the 8842A's most sensitive ranges. For that reason, they are also the most susceptible to error from electrical noise, thermal voltages, and (for resistance measurements) test lead resistance. You can minimize these sources of error by using good measurement practices.

The most common source of error is electrical noise. Typical sources of noise include electrostatic noise, inductive pickup noise, radio frequency noise, power line noise and noise generated by ground loop currents. Noise pickup can be minimized by properly shielding the test leads between the 8842A and the signal source.

For voltage measurements in most system applications, where common-mode voltages are typically present, connect the test lead shielding to the 8842A INPUT LO terminal as shown in Figure 4-10. This configuration minimizes the error caused by current that would flow in the leads due to common-mode voltages between the measurement and stimulus points and instrument ground. The 8842A's INPUT LO terminal is internally connected to the instrument's internal guard, which provides a shield between the instrument's ground and its sensitive analog circuits. The 8842A's analog circuits are isolated from its digital circuits by an electrostatically shielded transformer, whose shield is also connected to the guard.

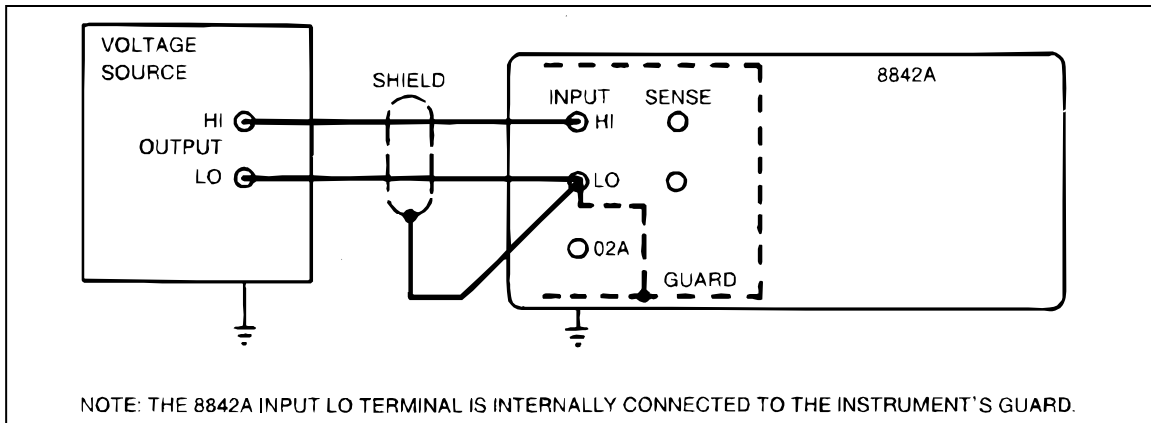

Figure 4-10. Shielding for Low Voltage Measurements

f4-10.wmf

For low-level resistance measurements, connect the test lead shielding as shown in Figure 4-11. Use the 4-wire ohms function to minimize the error caused by the resistance of the test leads.

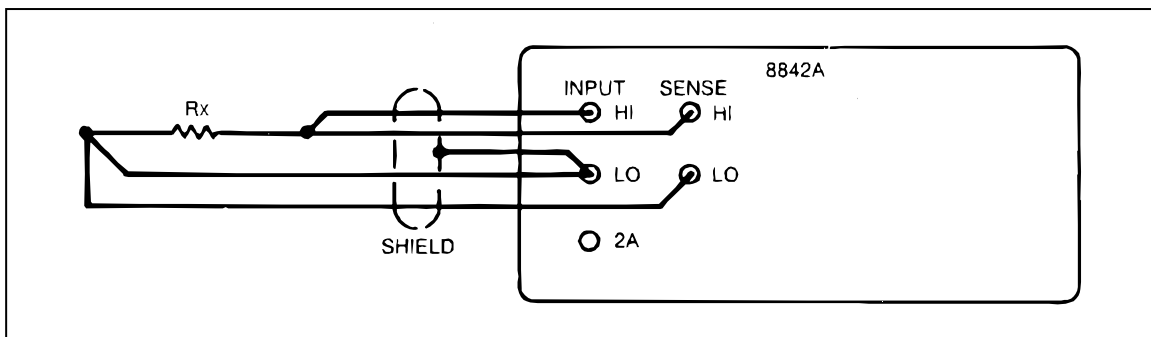

Figure 4-11. Shielding for Low Resistance Measurements

f4-11.wmf

Errors due to thermal voltages should also be considered when making low-level voltage or resistance measurements. Techniques for reducing thermal voltages are presented earlier in this section.

4-24. MAKING ACCURATE HIGH-RESISTANCE MEASUREMENTS

When high resistances are measured (typically 1 MΩ or greater), leakage resistance at the test circuit can provide enough shunt resistance to degrade the accuracy of the measurement (see Figure 4-12). To minimize leakage resistance, watch out for contamination, high humidity, poor-quality interconnections, and poor-quality insulation of the stand-offs on which test resistors are mounted.

High-resistance measurements are also susceptible to error from electrical noise pickup. For accurate measurements, use short test leads and enclose the test leads and test circuit in a proper shield that is connected to the 8842A's INPUT LO terminal. Pickup of slowly fluctuating noise can also be reduced by using the OFFSET feature as described in paragraph 4-7.

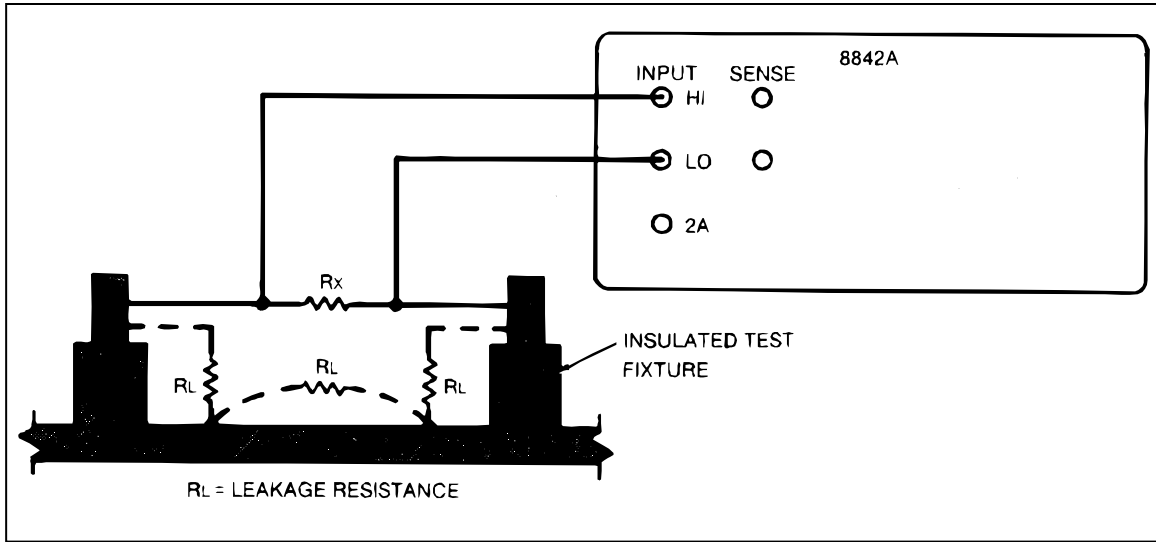

Figure 4-12. Leakage Resistance in High Resistance Measurement

f4-12.wmf

Chapter 5

Theory of Operation

	Title	Page
5-1.	INTRODUCTION	5-3
5-2.	OVERALL FUNCTIONAL DESCRIPTION	5-3
5-3.	DETAILED CIRCUIT DESCRIPTION	5-4
5-4.	DC SCALING	5-4
5-5.	VDC Scaling	5-6
5-6.	VDC Protection	5-7
5-7.	mA DC Scaling	5-7
5-8.	Analog Filter	5-7
5-9.	TRACK/HOLD CIRCUIT	5-8
5-10.	Track Configuration	5-10
5-11.	Settling Configuration	5-11
5-12.	Hold Configuration	5-11
5-13.	Pre-Charge Configuration	5-11
5-14.	PRECISION VOLTAGE REFERENCE	5-11
5-15.	OHMS CURRENT SOURCE	5-12
5-16.	OHMS PROTECTION	5-13
5-17.	OHMS FUNCTIONS	5-13
5-18.	2-Wire Ohms	5-13
5-19.	4-Wire Ohms	5-15
5-20.	A/D CONVERTER	5-15
5-21.	Timing/Data Control	5-17
5-22.	Precision DAC	5-17
5-23.	A/D Amplifier	5-18
5-24.	Bootstrap Supplies	5-18
5-25.	DISPLAY	5-18
5-26.	KEYBOARD	5-19
5-27.	DIGITAL CONTROLLER	5-19
5-28.	In-Guard Microcomputer	5-21
5-29.	Function and Range Control	5-23
5-30.	A/D Control and Computation	5-23
5-31.	Calibration Correction	5-23
5-32.	Keyboard/Display Control	5-24
5-33.	Troubleshooting Modes	5-24
5-34.	Guard-Crossing Communication	5-24
5-35.	GUARD CROSSING	5-24

5-36.	POWER SUPPLY	5-25
5-37.	IEEE-488 INTERFACE (OPTION -05).....	5-26
5-38.	Out-Guard Microcomputer.....	5-26
5-39.	Guard Crossing.....	5-26
5-40.	Bus Interface Circuitry	5-26
5-41.	Signal Conditioning	5-27
5-42.	IEEE-488 Interface Power Supply	5-27
5-43.	TRUE RMS AC (OPTION -09)	5-27
5-44.	VAC Scaling	5-27
5-45.	mA AC Scaling	5-28
5-46.	Frequency Response Trimming	5-28
5-47.	True RMS AC-to-DC Conversion	5-28

5-1. INTRODUCTION

This section presents an overall functional description of the 8842A, followed by a detailed circuit description. The descriptions are supported by simplified schematics in text and by the complete schematics in Section 10.

5-2. OVERALL FUNCTIONAL DESCRIPTION

A functional block diagram of the 8842A is shown in Figure 5-1. The basic signal path flows from left to right across the center of the page. The input is sensed at the input terminals, scaled, directed through the Track/Hold circuit, converted into digital representation by the Analog-to-Digital (A/D) Converter, processed by the Digital Controller, and sent to the display.

The DC Scaling circuit, which constitutes the "front end" of the instrument, has two major functions. First, it senses the input and produces an equivalent dc voltage for all functions except VAC and mA AC. (AC inputs are converted to a dc voltage by the True RMS AC Option.) Resistances are sensed as a dc voltage using a known test current from the Ohms Current Source. A dc current input is converted to a dc voltage by a precision current shunt.

Second, the DC Scaling circuit scales the equivalent dc voltages (for in-range inputs) to within the input range of the A/D Converter ($\pm 2V$). In addition, the DC Scaling circuit provides input protection and provides analog filtering for certain ranges and reading rates. (AC inputs are scaled by the True RMS AC Option.)

The Track/Hold (T/H) circuit samples the scaled dc voltage and presents the A/D Converter with a voltage that is constant for the input portion of each A/D conversion cycle. The T/H circuit also provides additional scaling for certain ranges.

The Digital Controller controls the operation of virtually every part of the 8842A. It reads the front panel keyboard, configures the instrument for each function and range, triggers the A/D Converter, calculates the result of each A/D conversion cycle, averages A/D samples, controls the display, and communicates with the IEEE-488 Interface Option via the Guard Crossing circuit. The heart of the Digital Controller is the In-Guard Microcomputer (μC).

The Guard Crossing circuit permits serial asynchronous communication between the Digital Controller and the IEEE-488 Interface Option, while isolating the two circuits electrically. Whereas the in-guard power supply floats with the voltage at the INPUT LO terminal, the IEEE-488 Interface Option operates with reference to earth ground. The "guard" is the isolation between the in-guard and out-guard circuits.

The Power Supply provides supply voltages to all parts of the instrument. The Precision Voltage Reference provides precise reference voltages for the A/D Converter and the Ohms Current Source.

5-3. DETAILED CIRCUIT DESCRIPTION

The following paragraphs give a detailed circuit description of each of the functional blocks in Figure 5-1. For clarity, measurement ranges are referred to as r1, r2, r3, etc., where r1 is the lowest possible range, r2 the next higher range, and so on. Pins are designated by the respective integrated circuit (e.g., U101-7 for U101 pin 7).

5-4. DC SCALING

The DC Scaling circuit scales all in-range dc inputs so that the output of the Track/Hold (T/H) amplifier (U307) is within $\pm 2V$. In addition, the DC Scaling circuit provides input protection and analog filtering. Additional scaling is provided by the the T/H Amplifier.

The following paragraphs describe the configuration of the DC Scaling circuit in the DCV and mA DC functions and also describe the analog filter. The ohms functions are described under a later heading because the T/H Amplifier provides additional input switching for these functions.

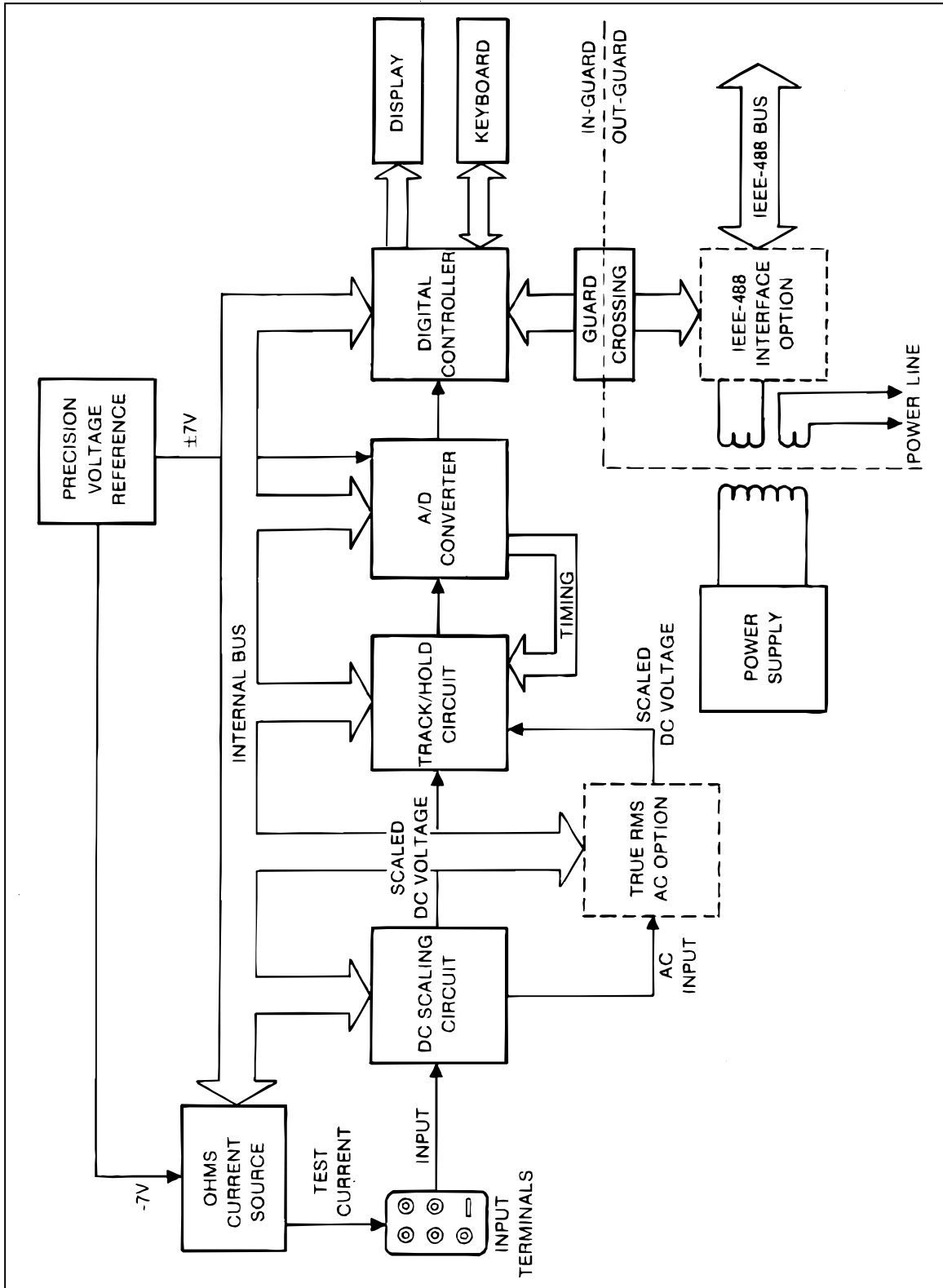

Figure 5-1. Overall Functional Block Diagram

f5-01.wmf

5-5. VDC Scaling

Scaling is performed in the VDC function by two precision resistors networks (Z301 and Z302). These components are configured by relay K301, switching transistor Q311, and quad analog switches U302A and U301B to provide the correct scaling for each range. Voltage follower U306 provides high input impedance for the 20V dc range. A simplified schematic and a switch state table for the VDC function are shown in Figure 5-2.

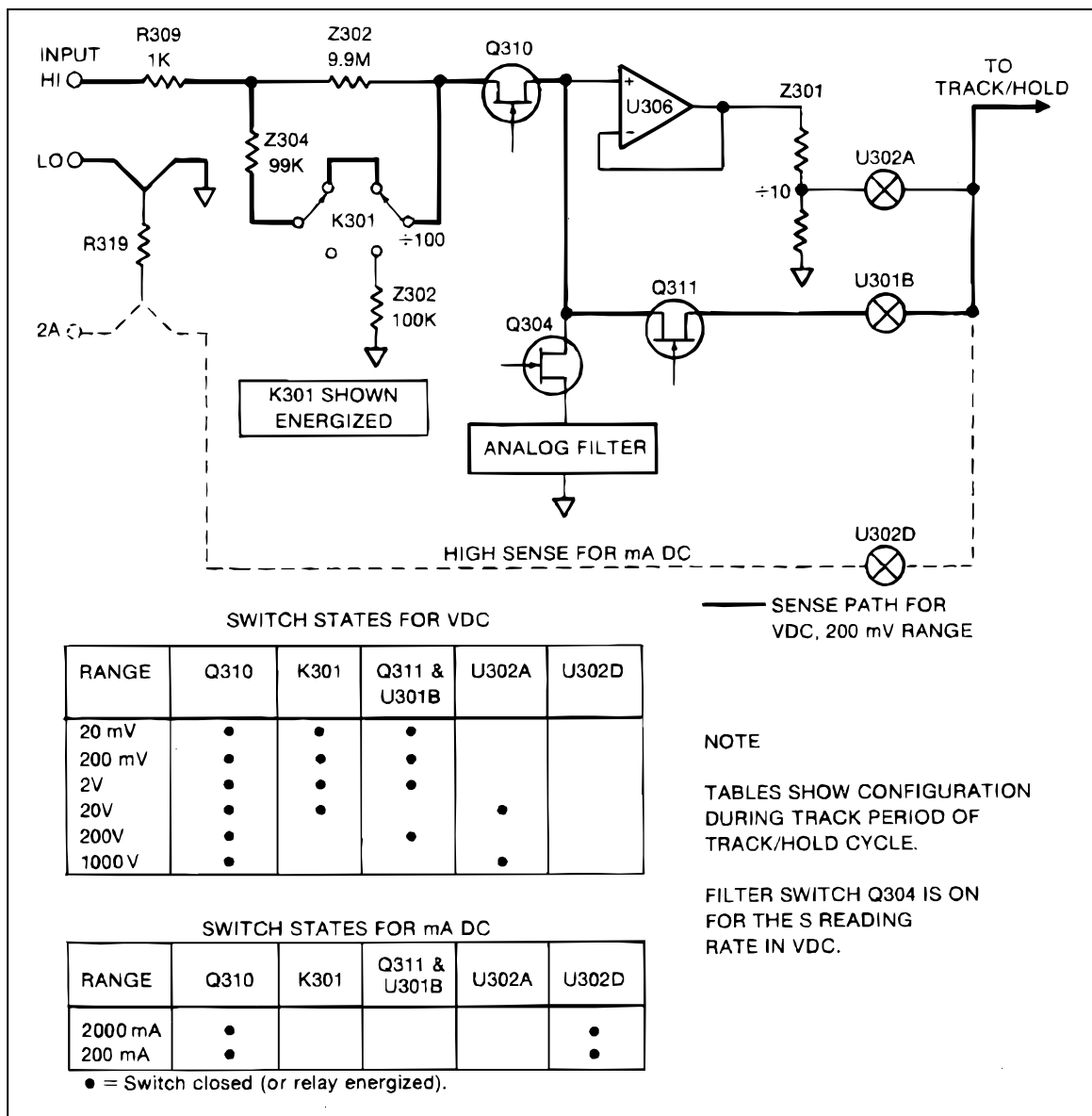

Figure 5-2. DC Scaling (VDC and mA DC)

f5-02.wmf

In the 20 mV, 200 mV and 2V ranges, the input voltage is applied directly to the T/H Amplifier via Q310, Q311, and U301B. In the 20 mV range, the T/H Amplifier has a gain of 100; in the 200 mV range, the T/H Amplifier has a gain of 10; in all other dc voltage ranges, the T/H Amplifier has a gain of 1.

In the 20V range, the input voltage is buffered by unity-gain amplifier U306, and divided by 10 by Z301. To allow U306 to handle +/-20V inputs, its power supplies are "bootstrapped" by Q305 and Q306, so that the output voltage of U306 determines the midpoint of its supply voltages. The positive supply is approximately 6.2V above the input and the negative supply is approximately 6.2V below.

In the 200V and 1000V ranges, K301 is de-energized and the input voltage is divided by 100 by Z302. In the 200V range, the reduced input voltage is then applied directly to the T/H Amplifier as in the 2V range. In the 1000V range, the reduced input voltage is buffered by U306 and divided by 10 as in the 20V range.

5-6. VDC Protection

Input protection for the VDC function is provided by a 1K, fusible resistor (R309), four metal-oxide varistors (MOVs) (RV301, RV402, RV403, and RV404), and additional protection resistors and clamp circuits.

WARNING

TO AVOID INJURY OR EQUIPMENT DAMAGE, USE EXACT REPLACEMENT PARTS FOR ALL PROTECTION COMPONENTS.

In all dc voltage ranges, voltage transients greater than 1560V are clamped by the MOVs. Extreme overvoltage conditions cause R309 to fail open-circuit.

R309 is followed either by a 99 k Ω , 10W resistor network (Z304) in the 20 mV, 200 mV, 2V, and 20V ranges, or by 10 M Ω (Z302) to ground in the 200V and 1000V ranges. Z304 provides current limiting in extreme overvoltage conditions in the 20 mV, 200 mV, 2V, and 20V ranges. The non-inverting input of U306 is clamped to +/-25V by Q307 and Q308.

5-7. mA DC Scaling

In the mA DC function, the unknown current causes a voltage drop across current shunt R319. This voltage drop is then measured as in the VDC function. The DC Scaling circuit is configured as shown by the simplified switch table in Figure 5-2.

5-8. Analog Filter

The three-pole, low-pass analog filter (U304) has a Bessel response with corner frequency at 7 Hz, giving approximately 50 dB of rejection at 50 Hz. The filter is used for the slow reading rate and is used in the VDC ranges and lowest three ohms ranges. The filter is also used in the 20mV DC, 20 Ω , and 200 mA DC ranges when in the medium reading rate. The filter is switched into the input signal path by Q304 (Figure 5-2). In some ranges and functions, additional filtering is provided by Q317 and C314.

5-9. TRACK/HOLD CIRCUIT

The Track/Hold (T/H) circuit presents a stable voltage to the A/D Converter during the input period of the A/D conversion cycle. The circuit also provides a gain of 100 in the 20 mV, 20 Ω and 200 mA ranges, and a gain of 10 in the 200 mV dc, 200 Ω , and 2000 mA dc ranges.

The T/H circuit consists of the T/H Amplifier (Figure 5-3), T/H capacitor C308, quad analog switches U301, U302, and U303, and associated components. As shown in Figure 5-3, the T/H Amplifier functions as an op amp, with Q314 supplying additional gain. In subsequent figures, the T/H Amplifier is represented as a single op amp.

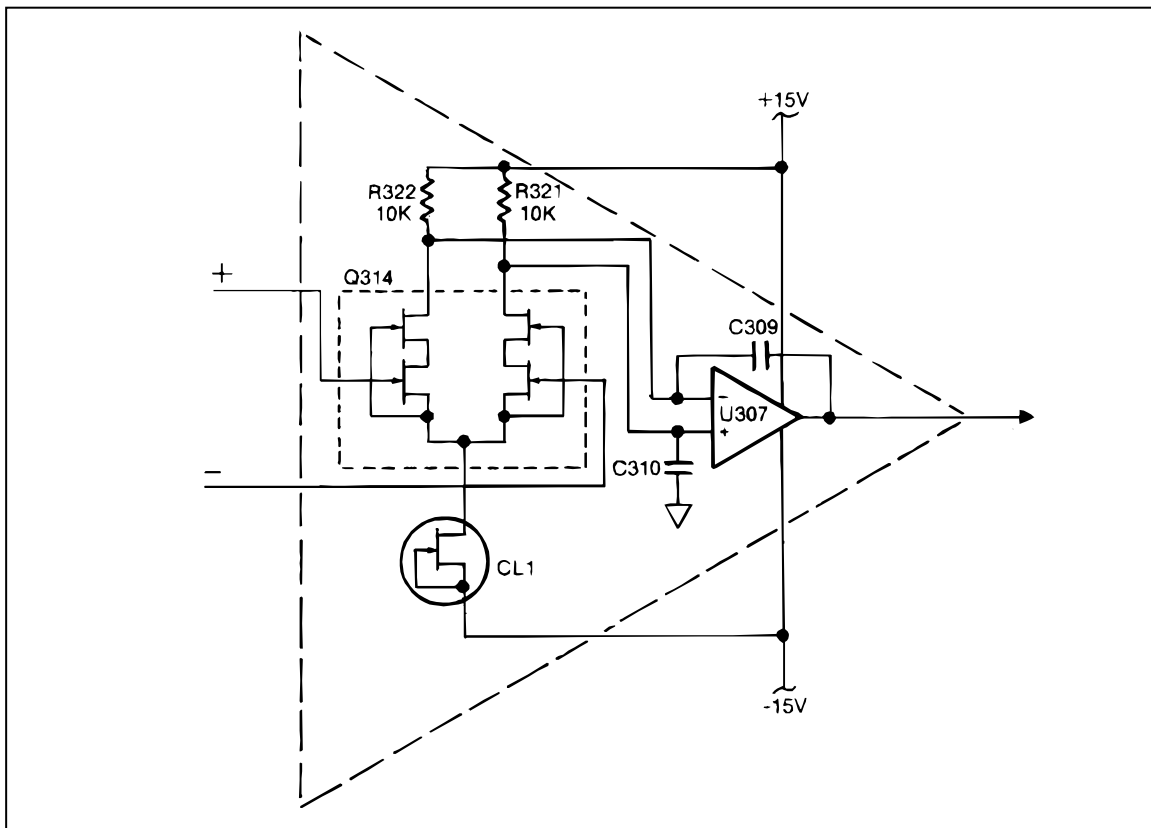
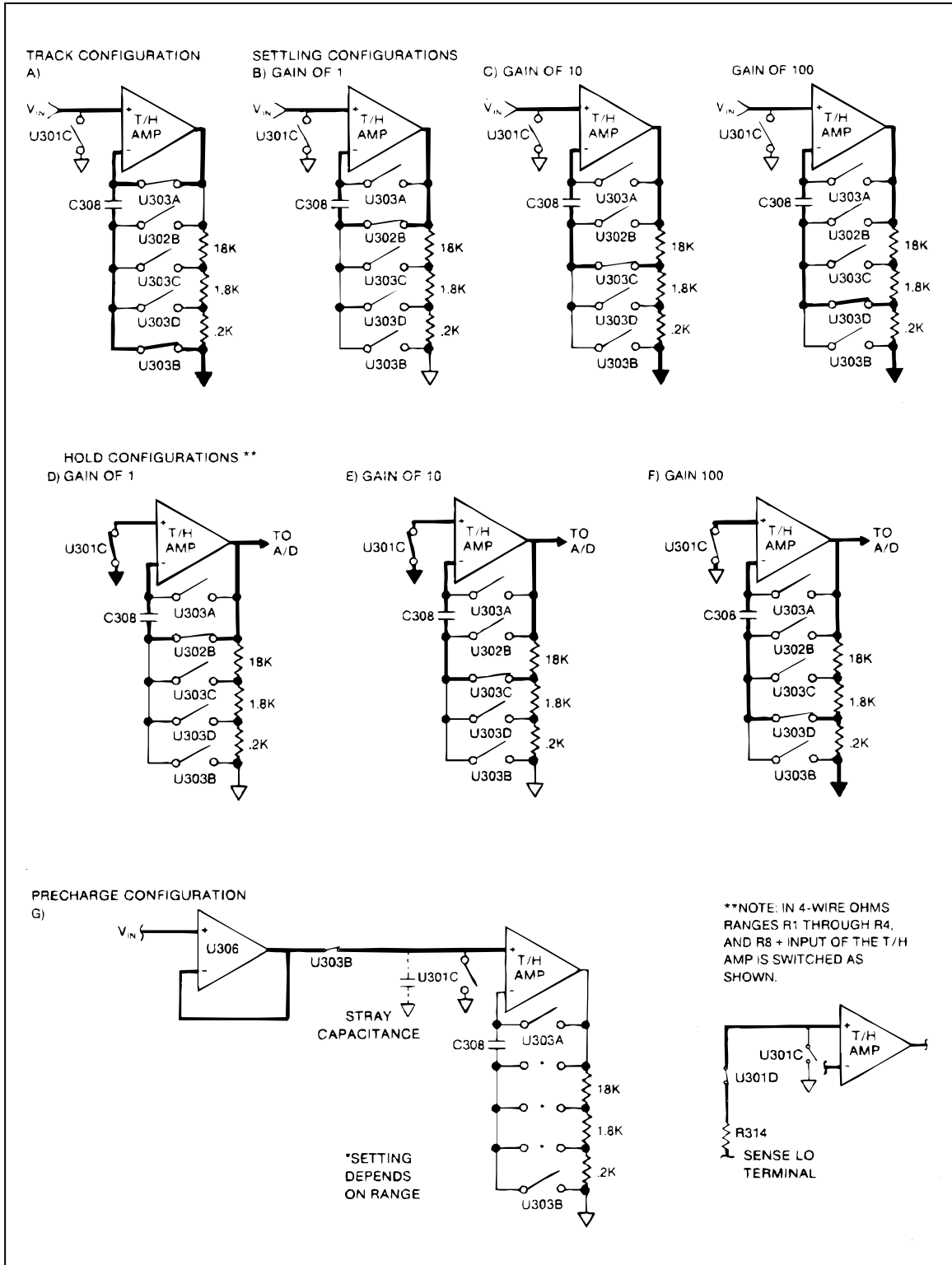

Figure 5-3. Track/Hold Amplifier

f5-03.wmf

The circuit operates by cycling between the track, settling, hold, and precharge configurations shown in Figure 5-4. The In-Guard μ C selects a particular settling and hold configuration for each function and range, and suppresses the precharge configuration for certain ranges. This control is achieved by latching function and range information in U301, U302, and U303.

Basic timing for the T/H circuit is provided by the A/D Converter over clock lines PC, HD1, TR1, and TR2. (See the timing diagram in Figure 5-5, top.) The T/H cycle is initiated when the In-Guard μ C pulls line TR low.



f5-04.wmf

Figure 5-4. Track/Hold Circuit Configurations

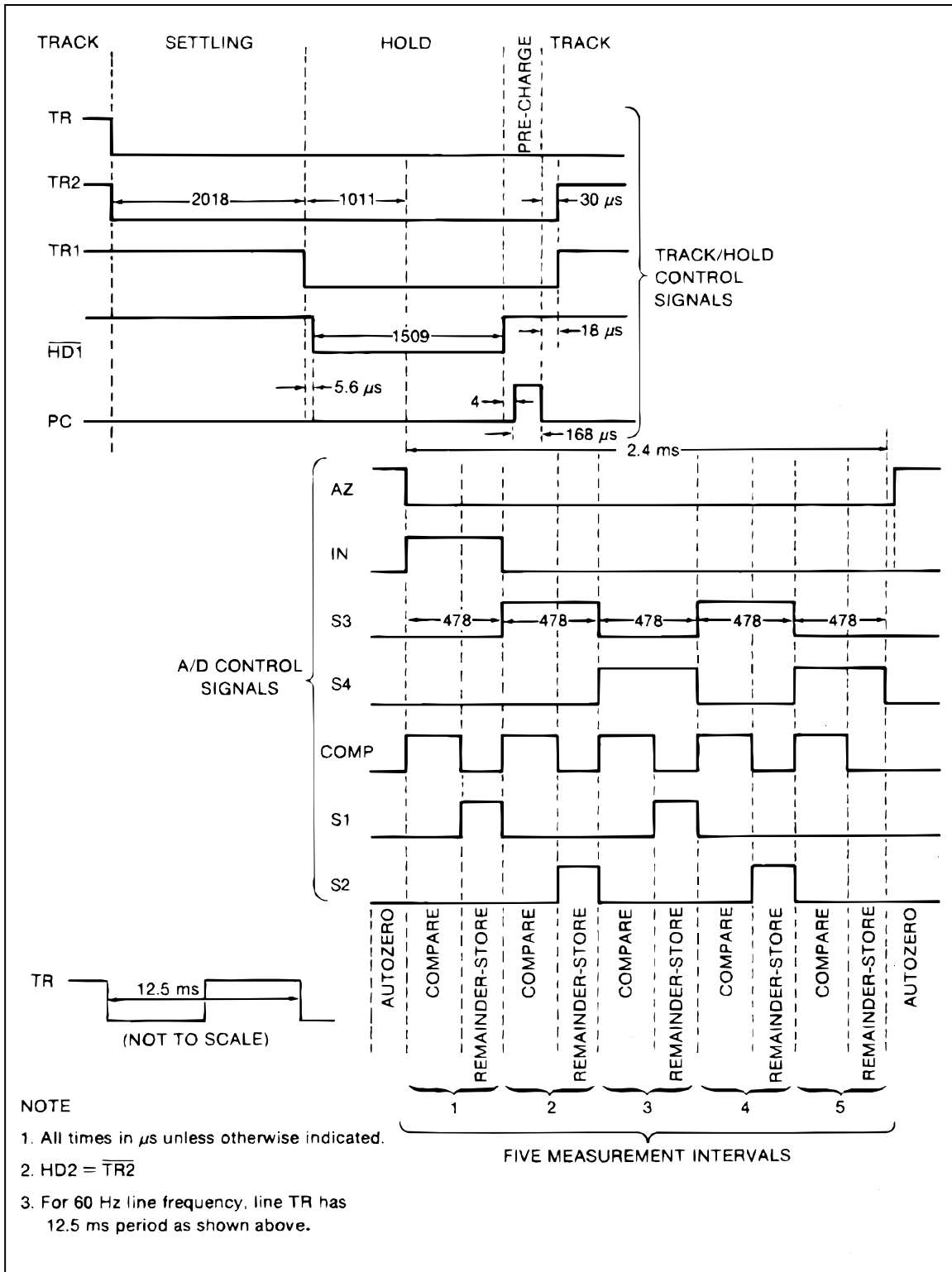

Figure 5-5. Timing Diagram for One A/D Cycle

f5-05.wmf

5-10. Track Configuration

In the track configuration (Figure 5-4A), the T/H circuit functions as a non-inverting buffer. The voltage on C308 tracks the scaled dc input voltage.

5-11. Settling Configuration

The circuit assumes a settling configuration between the track and hold configurations. The circuit assumes the configuration in Figure 5-4B for unity gain and the configuration in Figure 5-4C for gain of 10.

During this time the DC Scaling circuit is still connected to the T/H amp. However, changes in the input do not affect the value to be measured, which is stored on C308.

5-12. Hold Configuration

The X1 hold configuration (Figure 5-4D) is used for all VDC ranges except r1 and for all ohms ranges except r1. The output of U307 is the negative of the input voltage.

The X10 hold configuration (Figure 5-4E) is used for the mA DC function, the 200 mV dc range, and the 200Ω range, and provides a gain of 10.

5-13. Pre-Charge Configuration

The pre-charge configuration (Figure 5-4F) occurs after the hold configuration in VDC ranges r1, r2, and r4, and ohms ranges r1, r2, r3, and r4. U306 is connected as a buffer to charge stray capacitance at the non-inverting input of the T/H Amplifier. The pre-charge configuration is not used in any other ranges.

5-14. PRECISION VOLTAGE REFERENCE

The Precision Voltage Reference (Figure 5-6) provides precise reference voltages of -7.00000 and +7.00000. The reference element is a reference amplifier (ref amp). The nominal ref amp voltage is 6.5V.

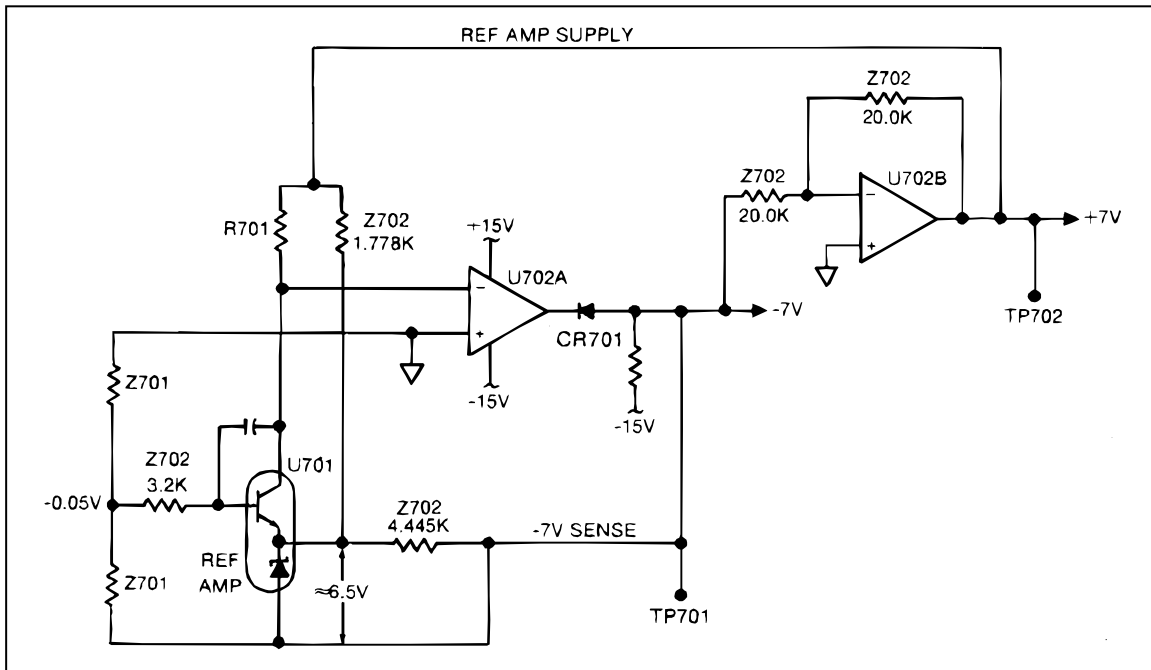

Figure 5-6. Precision Voltage Reference

f5-06.wmf

Resistor R701, precision resistor network Z701, and transistor/zener diode combination U701 are produced as a matched set so that the output of U702A is precisely -7.00000V. This output is remotely sensed at the pins of the custom A/D IC (U101). Diode CR701 prevents the output from going positive at power-up.

U702B functions as an inverter to provide the +7.00000V output and to supply the reference amplifier. The gain of U702B is set by the two 20 kΩ resistors in the resistor network Z702.

5-15. OHMS CURRENT SOURCE

The Ohms Current Source (Figure 5-7) provides a precise test current for the ohms functions. The first stage (U401, R401, and Q401) produces a precise reference current, using precision resistor R401 and a -7.0000V reference voltage from the Precision Voltage Reference.

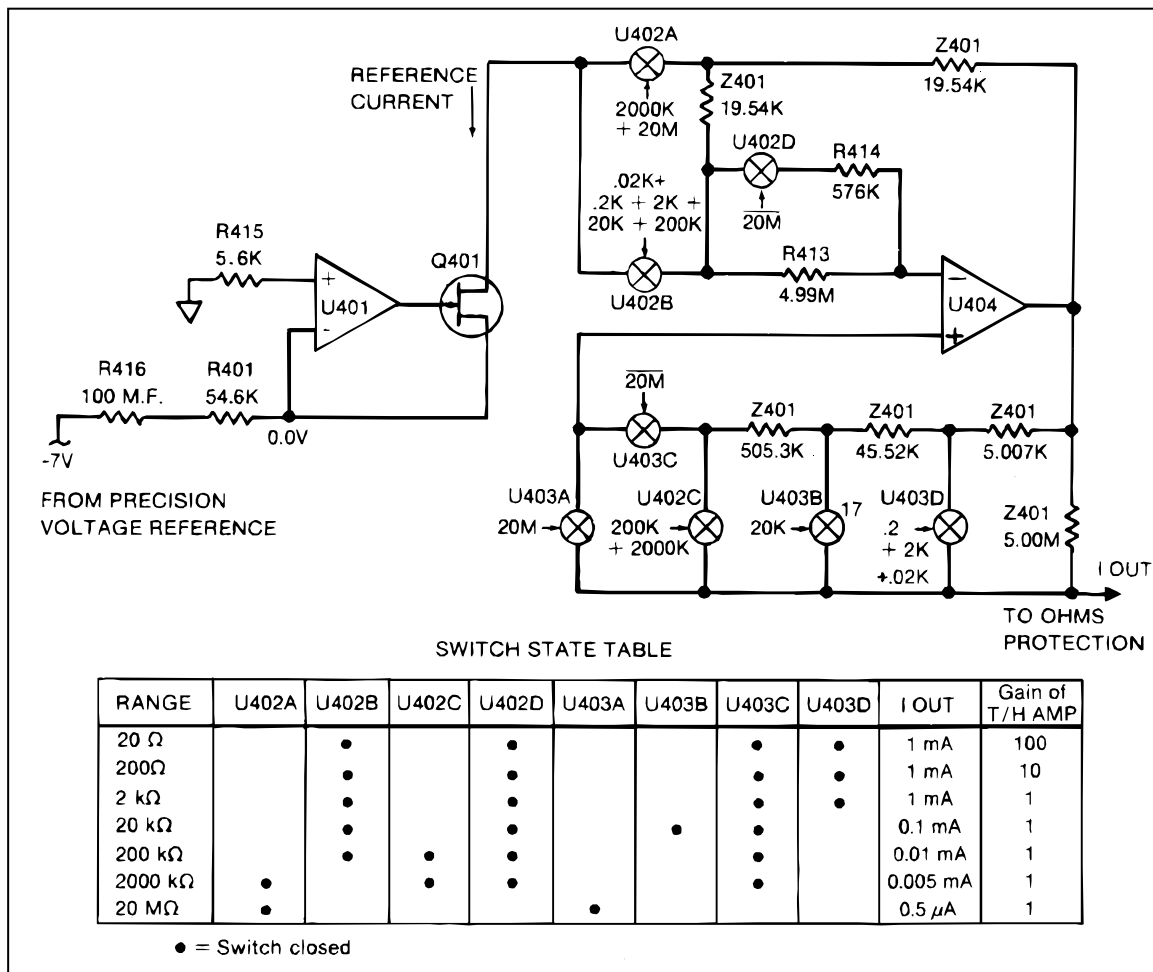

Figure 5-7. Ohms Current Source

f5-07.wmf

The second stage (U404, precision resistor network Z401, and analog switches U402 and U403) is a current amplifier whose gain is controlled by the In-Guard μC . The In-Guard μC sets the output current for each range by controlling U402 and U403. (See switch state table in Figure 5-7.)

5-16. OHMS PROTECTION

The Ohms Protection circuit (Q402, Q403, Q404, Q405, Q406, and Q407) clamps the open circuit voltage of the Ohms Current Source and provides protection for the Ohms Current Source.

The circuit protects the Ohms Current Source from up to $\pm 300\text{V}$ across the INPUT terminals. The circuit also clamps voltage transients larger than 1560V with four MOVs (RV401, RV402, RV403, and RV404). In addition, a $1\text{ k}\Omega$, 2W fusible wire-wound resistor (R410) in series with the output current path fails open-circuit under extreme overvoltage conditions.

Large positive input voltages are blocked by CR402. Large negative input voltages are dropped equally across three high-voltage transistors (Q402, Q403, and Q404). If -300V is present at the collector of Q404, the voltage drops equally across Z402 so that large negative voltages never reach the current source.

The circuitry associated with Q408 (R406, R407, R408, R409, Q406, Q408, and CR403) clamps the open-circuit voltage of the Ohms Current Source below $+6.5\text{V}$ in the lower four ranges and below $+13\text{V}$ dc in the higher two ranges. The in-guard μC turns Q408 on or off depending on range. In the lower four ohms ranges, Q408 is on, effectively shorting R409; R406 and R409 then form a voltage divider which clamps the output of the ohms current source below $+6.5\text{V}$. In the higher two ohms ranges, Q408 is off, including R409 in the voltage divider and clamping the output below $+13\text{V}$.

5-17. OHMS FUNCTIONS

5-18. 2-Wire Ohms

In the 2-wire ohms function, the Ohms Current Source is connected to the INPUT HI terminal by ohms relay K401 (Figure 5-8). The Ohms Current Source applies a known current to the resistance under test, and the resulting voltage drop across the resistor is measured ("sensed") as in the VDC function.

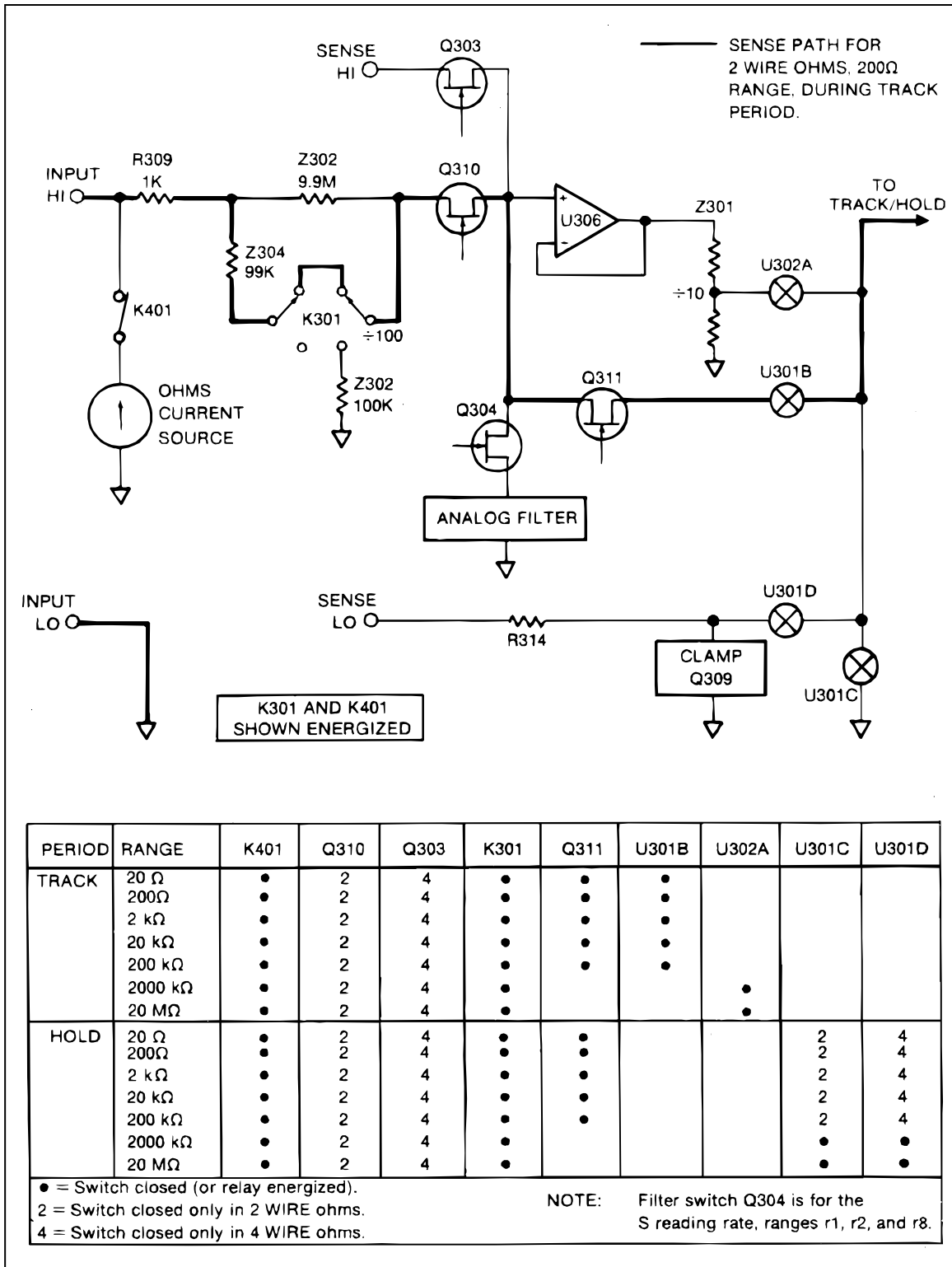

Figure 5-8. Ohms Scaling

f5-08.wmf

The voltage sensed at the INPUT terminals is scaled as shown by the simplified switch table in Figure 5-8. (Refer to the track period of the track/hold cycle, during which the scaled input voltage is sampled.)

In the lower five ranges, the full scale input voltage to the A/D Converter is 2V. However, in the 2000 k Ω and 20 M Ω ranges, the full-scale input voltage to the A/D Converter is +1V; the in-guard uC completes the scaling by multiplying the A/D result by 2.

5-19. 4-Wire Ohms

In the 4-wire ohms function, the Ohms Current Source is connected to the INPUT HI terminal by ohms relay K401 as in 2-wire ohms (Figure 5-8). The Ohms Current Source applies a known current to the resistance under test through the INPUT HI and INPUT LO leads. The resulting voltage drop across the resistor is measured by the SENSE HI and SENSE LO leads.

The voltage at the SENSE HI terminal is connected to the DC Scaling circuit by Q303 (Figure 5-8). The voltage is then scaled exactly as in the 2-wire ohms function. (Refer to the track period in the switch table in Figure 5-8.) Q310 is turned off to isolate the SENSE HI terminal from the INPUT HI terminal.

Additional input switching occurs during the hold period of the track/hold cycle. (Refer to the hold period in the switch table in Figure 5-8.) In ranges r1 through r4, and r8, the SENSE LO terminal is switched into the dc input path by U301D, and the INPUT LO terminal is switched out of the dc input path by U301C. This has the effect of measuring the SENSE HI terminal with respect to the SENSE LO terminal.

In ranges r5 and r6, the SENSE LO and INPUT LO terminals are both switched into the dc input path by U301C and U301D during the hold period. This has the effect of measuring the SENSE HI terminal with respect to INPUT LO terminal rather than SENSE LO. Although the resistance of the INPUT LO lead is in series with the unknown resistance, accuracy is not affected as long as the resistance of the lead is less than 10 Ω in the 2000 k Ω range and less than 100 Ω in the 20 M Ω range.

5-20. A/D CONVERTER

The Analog-to-Digital (A/D) Converter (Figure 5-9) uses Fluke's patented recirculating remainder technique. An input voltage (V_{in}) is compared to the output of the precision Digital-to-Analog Converter (DAC). The output of the A/D Amplifier, connected as a comparator, is monitored to indicate when the DAC output is larger than the input voltage.

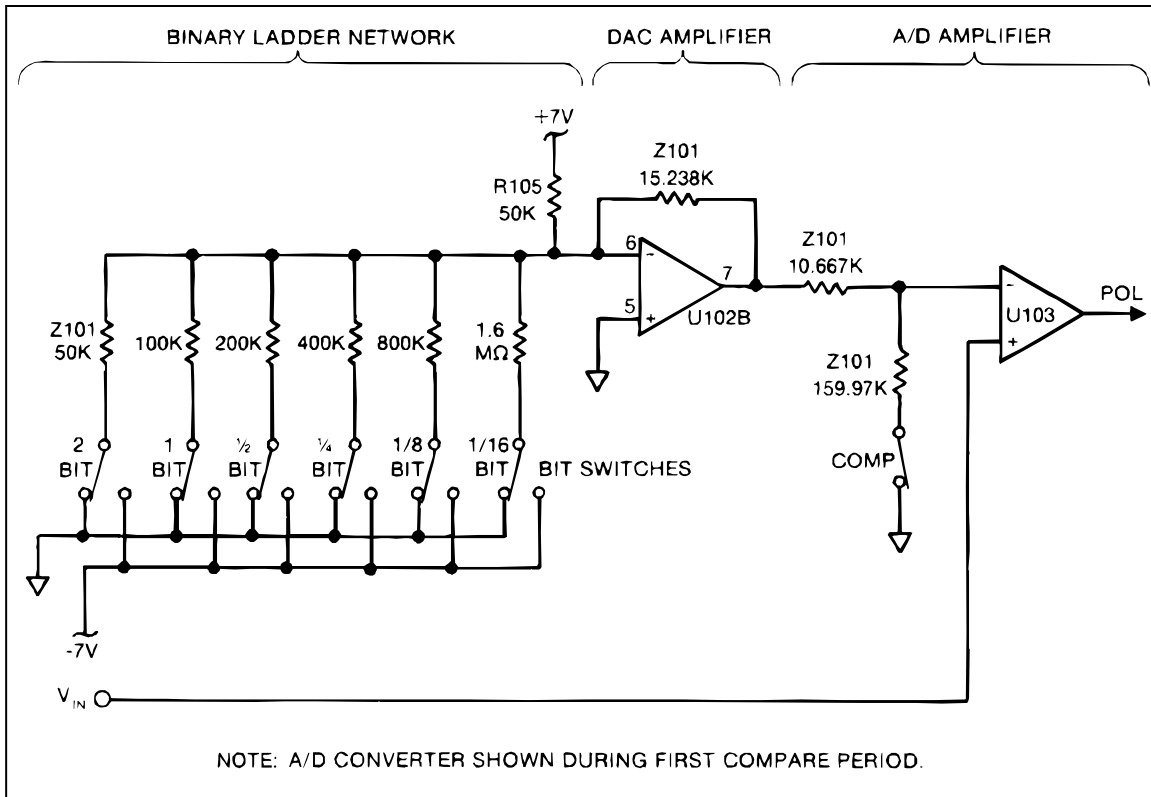

f5-09.wmf

Figure 5-9. Analog-to-Digital Converter

The conversion process is broken up into an autozero period followed by five measurement intervals. (A timing diagram is shown in Figure 5-5.) Six bits of the final A/D sample are obtained during each interval.

During the first compare period (shown in Figure 5-9), the A/D Converter determines the value of the scaled input voltage (V_{in}) by comparing V_{in} to the output of the DAC. Each of the DAC bit-switches is tried in sequence and kept or rejected (left closed or reopened) depending on the output polarity of the A/D Amplifier, which is configured as a comparator. This process produces a string of six bits which is stored in the Timing/Data Control circuit (the digital portion of U101).

During the following remainder-store period (Figure 5-10), the difference between the V_{in} and the DAC output is multiplied by 16 by the A/D Amplifier and stored on capacitor C102. During subsequent compare and remainder-store periods, the remainder voltage is connected to the input of U103 and is resolved to six bits; the remainder voltage (multiplied by 16) is stored alternately on capacitor C102 and C103. Each of the five compare periods thus produces a six-bit nibble which is stored in the Timing/Data Control circuit.

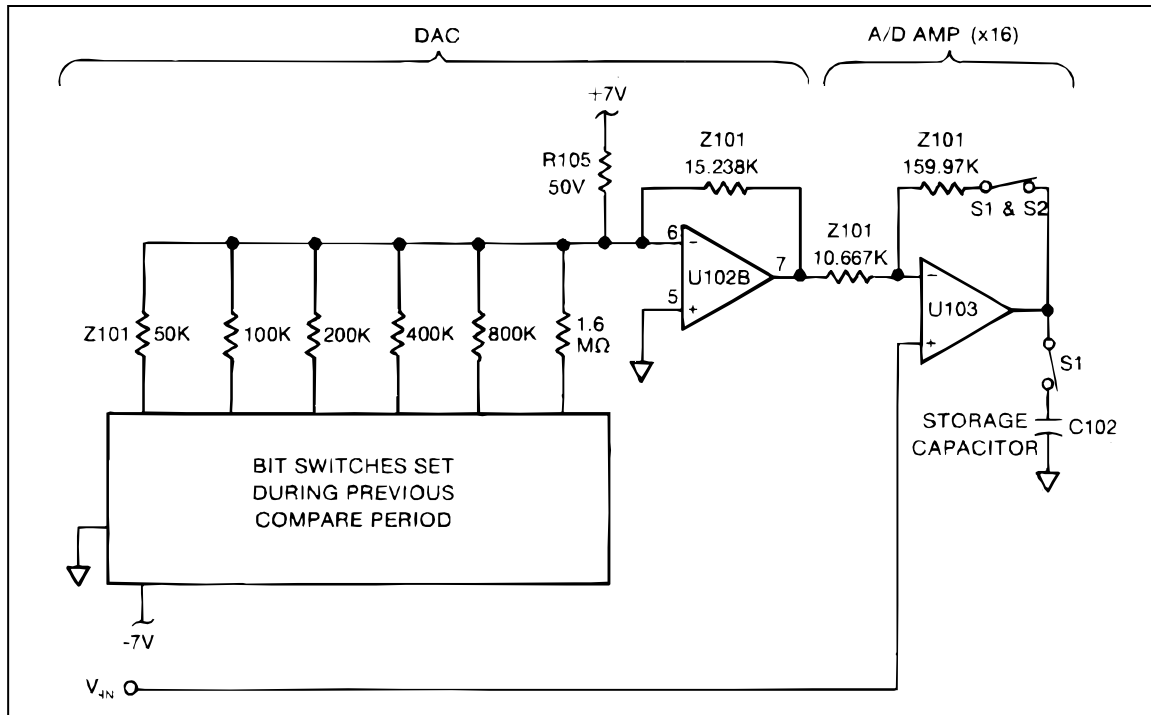

Figure 5-10. First Remainder-Store Period

f5-10.wmf

This five-interval process thus generates five nibbles which are processed by the In-Guard μC to produce one A/D sample. After the fifth nibble is generated, U101 interrupts the In-Guard μC over line INT. The In-Guard μC then pulls line CS7 low five times, causing U101 to send the μC the five (six-bit) nibbles one-at-a-time over lines AD0-AD5. The In-Guard μC then weights each nibble 1/16 of the value of the previous number and calculates the input voltage.

The hardware for the A/D Converter has four major sections: Timing/Data Control, Precision DAC, A/D Amplifier, and bootstrap supplies.

5-21. Timing/Data Control

The Timing/Data Control circuit (the digital portion of U101) times and controls the A/D Converter by manipulating the switches in the A/D Amplifier and the bit-switches in the Precision DAC. An A/D conversion cycle is triggered by the falling edge of line TR from the In-Guard μC . Once triggered, the A/D Converter (under control by U101) generates the five 6-bit nibbles without further interaction with the In-Guard μC .

The Timing/Data Control circuit also provides a watch-dog timer (line RES not) which resets the In-Guard μC in case normal program execution is interrupted. If the timer senses inactivity on line CS7 for longer than 1.5 seconds, it resets the In-Guard μC by pulling RES not low.

The Timing/Data Control circuit is supplied with a fixed-rate 8 MHz clock and provides a 1 MHz output clock for the Keyboard/Display Interface (U212). In addition, four output lines (PC, HD1 not) TR1, and TR2) provide control signals for the Track/Hold circuit.

5-22. Precision DAC

The Precision Digital-to-Analog Converter (DAC) is composed of DAC Amplifier U102B and a binary ladder network, which consists of resistors in Z101 and digitally controlled analog bit-switches contained in U101.

The bit-switches determine the output voltage of U102B by controlling the binary ladder network. The gain of U102B is set by the ratio of a precision feedback resistor (Z101-7, -8) and the equivalent output resistance of the ladder network.

5-23. A/D Amplifier

The A/D Amplifier is composed of a comparator/amplifier (U103), two remainder-storage capacitors (C103 and C102), an autozero storage capacitor (C101), and several digitally controlled analog switches contained in U101.

The A/D Amplifier has three modes of operation: autozero mode, where any offsets in the A/D input are stored on C101 so as to be cancelled later; compare mode, where the A/D input is compared to the DAC output; and remainder-store mode, where U103 amplifies and stores the difference between the A/D input and the DAC output on one of the two remainder-storage capacitors (C102 or C103). The autozero mode is shown in Figure 5-11. The other modes are shown in Figures 5-9 and 5-10.

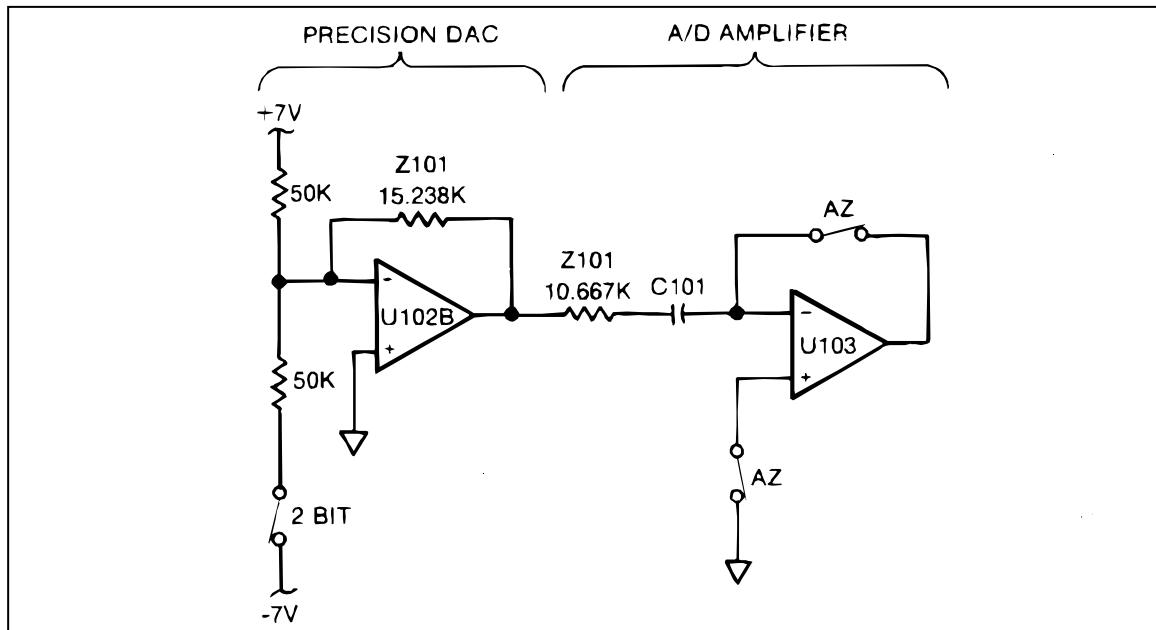

Figure 5-11. Autozero Period

f5-11.wmf

5-24. Bootstrap Supplies

The bootstrap supplies are composed of U102A, Q101, Q102, CR103, CR104, and associated components. The bootstrap supplies enhance the gain accuracy of U103. During compare periods, the bootstrap supplies limit the output of U103 to minimize the time it takes to recover from being driven to a supply rail. Both functions are achieved by manipulating the supplies of U103 (BS1 and BS2).

5-25. DISPLAY

The vacuum fluorescent display is similar to a vacuum tube, containing eight control grids and 69 phosphor-coated plates which form the display segments and annunciators. (See Figure 5-12.) The filament voltage is 4.5V ac, with a +5V dc bias. Each plate is controlled by a G line and a P line. The G lines go to the control grids, and the P lines go to the plates.

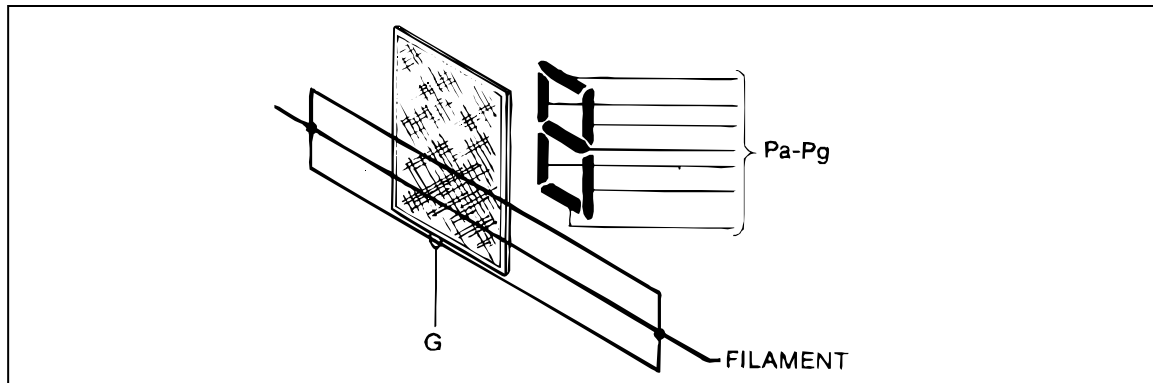

Figure 5-12. Vacuum Fluorescent Display

f5-12.wmf

The Digital Controller sequentially enables the G lines by applying +30V dc (nominal). When a G line is enabled, electrons flow from the filament to the enabled grid. If a P line is enabled (i.e., raised to a nominal +30V dc by the Digital Controller), the electrons continue past the grid and strike the respective plate, causing it to glow.

5-26. KEYBOARD

The keyboard consists of a silicone-rubber switch matrix located over metalized epoxy contacts on the printed wire board. Each button contains a conductive pad that shorts two contacts when pressed.

5-27. DIGITAL CONTROLLER

The Digital Controller (Figure 5-13) consists of the In-Guard μ C (U202), External Program Memory (U222), Calibration Memory (U220), Keyboard/Display Interface, and associated components.

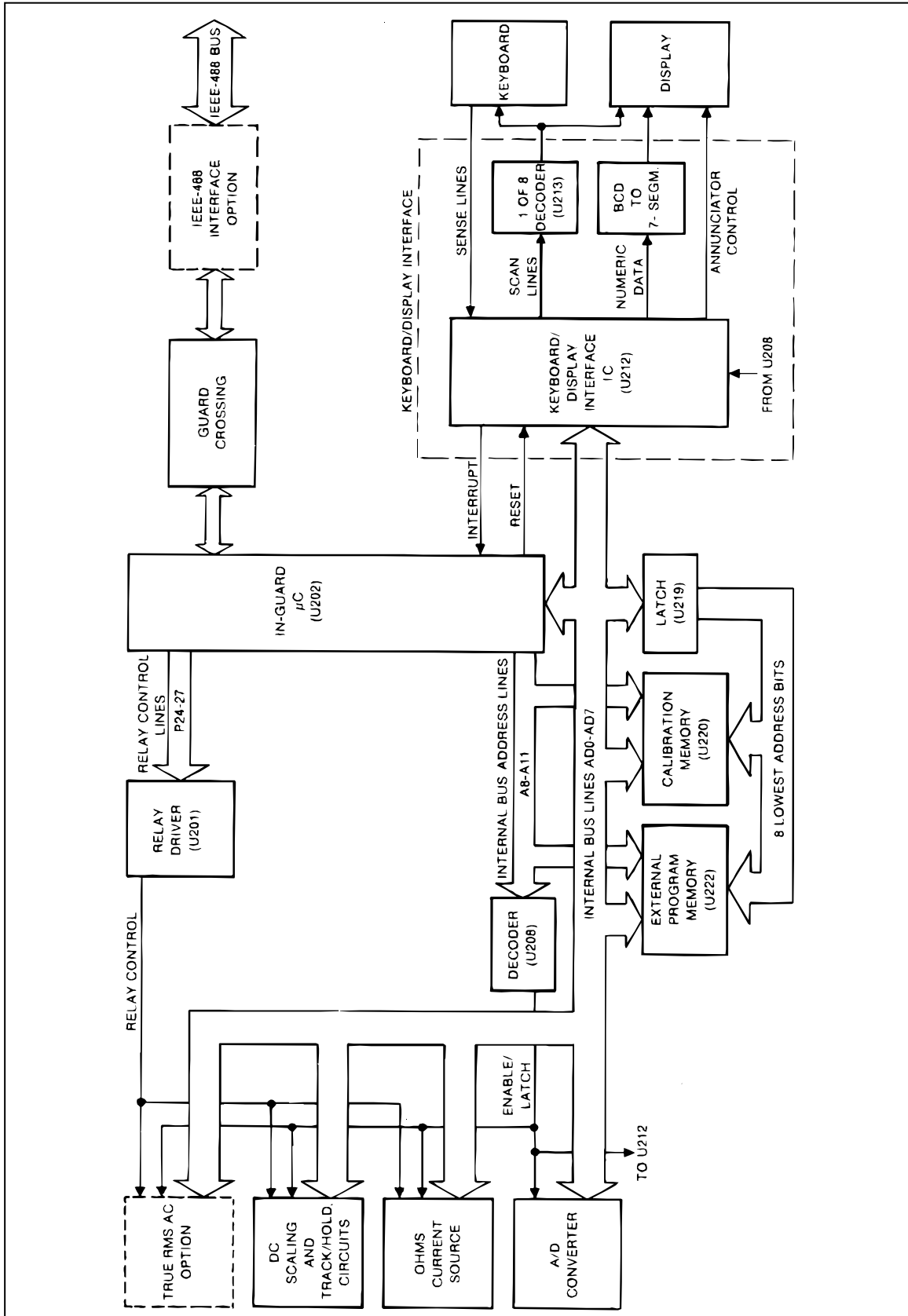

Figure 5-13. Digital Controller Block Diagram

f5-13.wmf

5-28. In-Guard Microcomputer

The In-Guard Microcomputer (μC) is a single-chip Z8 microcomputer containing 4K bytes of ROM, 144 bytes of RAM, a UART, and four 8-bit I/O ports. It communicates with the rest of the instrument via the internal bus and dedicated I/O lines. The In-Guard μC is reset when pin 6 is pulled low either by C204 at power-up or by the watch-dog timer in the custom A/D IC (U101). Pin 6 is tied to +5V through a 100 k Ω resistor inside the μC .

All internal bus communication is memory-mapped. Each component that sends or receives data on the bus has a unique address or range of addresses. The internal bus consists of lines AD0-AD7 and A8-A11. Lines AD0-AD7 are time-multiplexed to carry both the least-significant address byte and the data. Lines A8-A11 carry the most-significant bits of the address. The μC writes to and reads from the internal bus according to the read and write cycles shown in Figure 5-14. During either cycle, the address strobe (AS) changes from low to high when an address is valid, and the data strobe (DS) changes from low to high when the data is valid.

The address strobe latches the address on AD0-AD7 into U219 which then provides static address inputs for those devices that need it while data is on the bus. The data memory line (DM) divides the address space between program memory (U222) and data memory (all other devices on the bus). The data memory address space is further divided between the calibration memory (U220) and the remaining devices by A11. The addresses of the remaining devices are decoded from A8-A10 by U208, which combines the address with the data strobe (DS) to provide a chip select (CS0, CS2, CS3, CS4, or CS7) for each device.

The In-Guard μC performs the following functions: range and function control; A/D control and computation; calibration corrections; keyboard/display control; serial communication with the IEEE-488 Interface; and diagnostic self-testing and troubleshooting.

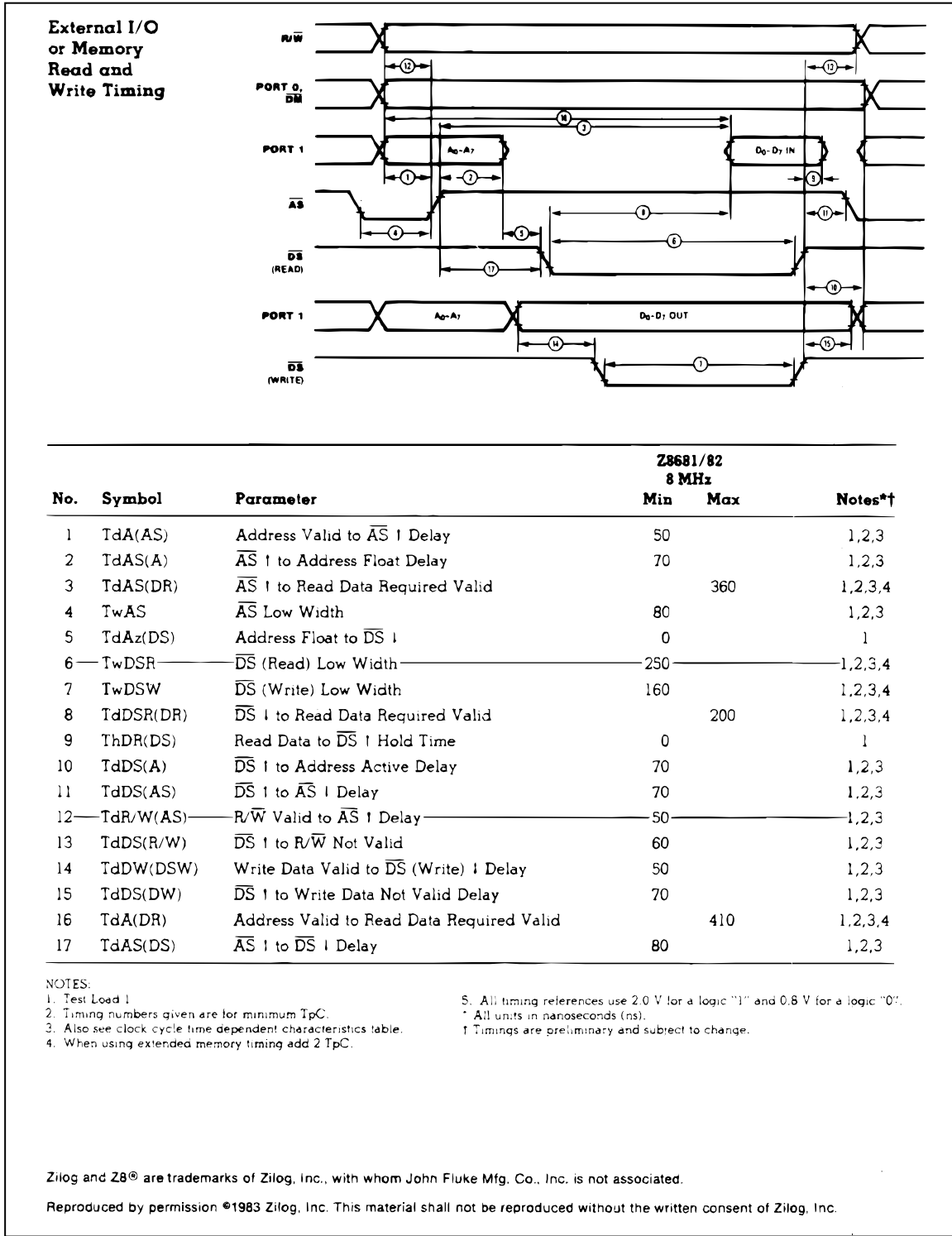

f5-14.wmf

Figure 5-14. Read/Write Timing Diagrams for Internal Bus

5-29. Function and Range Control

The In-Guard μC configures the DC Scaling circuit, the Track/Hold circuit, and the Ohms Current Source to provide the proper input switching, scaling, and filtering for each function, range, and reading rate. It does this by controlling dedicated output lines which control relays and FET switches, and by sending configuration codes out on the bus. The quad analog switches (U301, U302, U303, U402, and U403) latch the configuration codes and perform any level-shifting needed to control their internal MOSFET switches. Some of the switches require dynamic timing signals from the custom A/D IC (U101); these signals are combined appropriately in the quad analog switches with the configuration codes.

5-30. A/D Control and Computation

The In-Guard μC initiates each A/D sample by pulling line TR low. When the μC is reset, it senses the power line frequency on line FREQ REF . The μC then sets its internal timer so that the A/D sample rate is as shown in Table 5-1.

The number of readings per second for the slow and medium rates are chosen to provide rejection of input signals that are at the line frequencies.

Table 5-1. Sample Rates and Reading Rates

POWER LINE FREQUENCY	SLOW		MEDIUM		FAST	
	Samples per Sec	Samples per Reading	Samples per Sec	Samples per Reading	Samples per Sec	Samples per Reading
50 Hz	66.67	32	66.67	4	100	1
60 Hz	80	32	80	4	100	1
400 Hz	76.19	32	76.19	4	100	1

The custom A/D IC (U101) generates five 6-bit numbers after each trigger from the μC and then pulls INT low, telling the μC that data is ready. The μC reads the five 6-bit numbers over the bus (CS7 pulses low five times for five read cycles) and computes the value of the A/D sample using calibration constants. The μC averages the appropriate number of samples for one reading, which is then sent to the keyboard/display interface for display.

For example, with a 60-Hz power-line frequency, an externally triggered reading in the slow reading rate would cause the μC to send 32 pulses on TR at an 80 Hz rate. The 32 A/D samples would be calibrated and averaged by the μC and sent for display. With internal triggering, the A/D runs continuously at 80 samples per second with a reading being sent to the display every 32 samples.

5-31. Calibration Correction

The calibration constants used by the In-Guard μC in computing each reading are stored in the EEROM (electronically erasable read-only memory) Calibration Memory (U220). The front panel CAL ENABLE switch protects the EEROM from accidental writes.

5-32. Keyboard/Display Control

Keyboard/Display Controller U212 communicates with the In-Guard μ C over the internal bus. During a μ C write cycle, address line A0 tells U212 whether to consider data being sent by the μ C as configuration commands or as display data. Display data is stored in the Keyboard/Display Controller, which automatically scans the display. The Keyboard/Display Controller selects one of eight grids using decoder U213 and buffer U215. The numeric display data is decoded from BCD to 7-segment by decoder U216 and buffered by U217. Additional annunciator data is buffered by U218.

The Keyboard/Display Controller is reset by the μ C whenever the μ C is reset. It receives a 1-MHz clock signal from the custom A/D IC (U101), which uses the μ C 8-MHz crystal for its clock input.

The Keyboard/Display Controller scans the keyboard, sensing pressed buttons on lines RL0-RL7. It sends an interrupt to the μ C via line KEYINT whenever a front panel button is pressed. The μ C then reads the keycode from the Keyboard/Display Controller. (The status of the FRONT/REAR switch is sensed separately by line F/R SENSE.)

5-33. Troubleshooting Modes

In addition to running the diagnostic self-tests, the In-Guard μ C has a troubleshooting mode which aids in finding digital hardware problems. After the μ C is reset, it senses the relay control lines (U202-35 through U202-38) as inputs. If line U202-38 (TP205) is shorted to ground, the μ C goes into the troubleshooting mode. (U201 provides internal pull-up.) The troubleshooting mode is described in detail in the Maintenance section.

5-34. Guard-Crossing Communication

The In-Guard μ C contains a UART (universal asynchronous receiver transmitter) which it uses to communicate across the guard to the IEEE-488 Interface. The transmission speed is 62,500 bits per second.

5-35. GUARD CROSSING

The Guard Crossing consists of two identical circuits, each of which transmits data in one direction across the guard isolation between the Main Printed Circuit Assembly and the IEEE-488 Interface. One circuit is shown in Figure 5-15; the other circuit works identically. A portion of each circuit is contained in the IEEE-488 Interface.

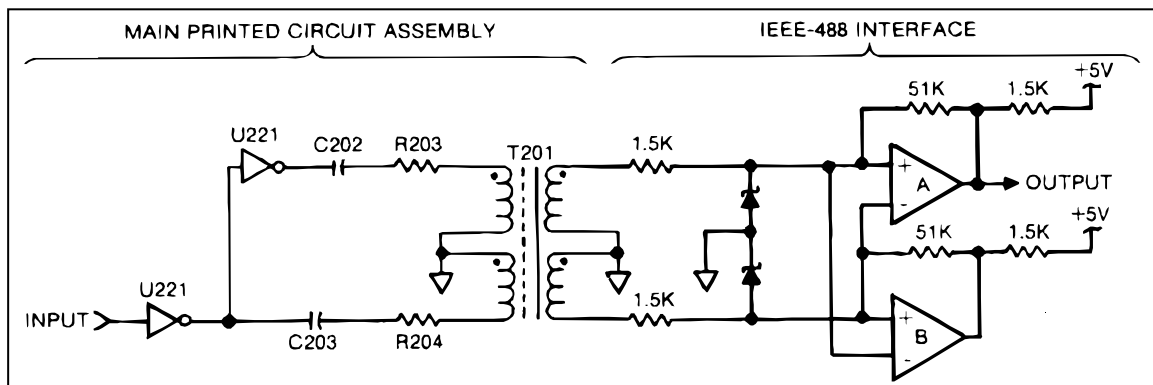

Figure 5-15. Guard Crossing Circuit

f5-15.wmf

The circuit in Figure 5-15 has two stable states, corresponding to output high (+5V) and output low (0V). If the output is high, the voltage present at the non-inverting input of op amp A is approximately +140 mV.

Since the inputs to op amps A and B are inverted, their outputs are always in opposite states. If the output of A is high, the output of B is low, forcing the inverting input of A (and the non-inverting input of B) to ground, hence reinforcing the existing state. The situation is analogous if the output of A is low.

A positive-going transition at the input causes a positive pulse at the non-inverting input of A, and a corresponding negative pulse at the inverting input of A. If the output is high to start with (with the non-inverting input of A raised 140 mV above its inverting input), these pulses reinforce the existing state (raising the non-inverting input and lowering the inverting input). If, however, the output is low to start with, the positive pulse (which is greater than 140 mV) raises the non-inverting input of A above its inverting input, switching the output to the high state. The situation is analogous for a negative-going input transition.

5-36. POWER SUPPLY

The Power Supply provides the following in-guard outputs: +/-30V, +/-15V, -6.2V, +7.5V, +5V, -5V, and -8.2V dc; and 4.5V ac. The Power Supply also provides a 16V ac center-tapped out-guard output.

Input line voltage is directed to the primary transformer winding through fuse F601, the front panel POWER switch, and the rear panel LINE SET switches. Metal oxide varistor RV601 clamps line transients at about 390V. The LINE SET switches configure the Power Supply to accept line power of 100, 120, 220, or 240V ac (+/-10% with a maximum of 250V) at 50, 60, or 400 Hz.

AC voltage for the +5V supply is rectified by CR601 and CR602 and regulated by VR601. The +5V output supplies mostly logic circuits. The ac input to the +5V supply is sensed by the In-Guard μ C (via R604, CR615, and U221-12, 13) to measure the line frequency.

AC voltage for the +30V and -30V supplies is rectified by bridge network CR603, CR604, CR605, and CR606 and regulated by VR602 and VR605. The +30V and -30V outputs supply front-end buffer amp U306. In addition, the +30V output supplies the anodes of the vacuum fluorescent display. Zener diode CR612 supplies -6.2V to the A/D Converter clamps.

AC voltage for the +15V and -15V supplies is rectified by bridge network CR608, CR609, CR610, and CR611 and regulated by VR603 and VR604. The +15V and -15V supply analog circuitry throughout the 8842A. Zener diodes CR613 and CR614 supply +7.5V and -8.2V to the A/D Converter, analog filter, and DC Scaling circuit.

Secondary T601-14, 15, 16 supplies the vacuum fluorescent display filament with 4.5V ac. The center tap is connected to the in-guard +5V supply in order to correctly bias the display. An isolated secondary supplies 16V ac to the power supply on the IEEE-488 Interface.

Zener diode CR615 and SCR Q601 comprise a protective crow-bar circuit. If the line voltage exceeds the nominal value by approximately 30 percent or more, CR615 conducts, turning on Q601, shorting out the power transformer secondary and blowing the line fuse. In normal operation, these components have no effect.

5-37. IEEE-488 INTERFACE (OPTION -05)

The IEEE-488 Interface has five major parts, as shown in the block diagram in Figure 5-16. All components are contained in a single printed circuit assembly (PCA). Reference designations are numbered in the 900 series.

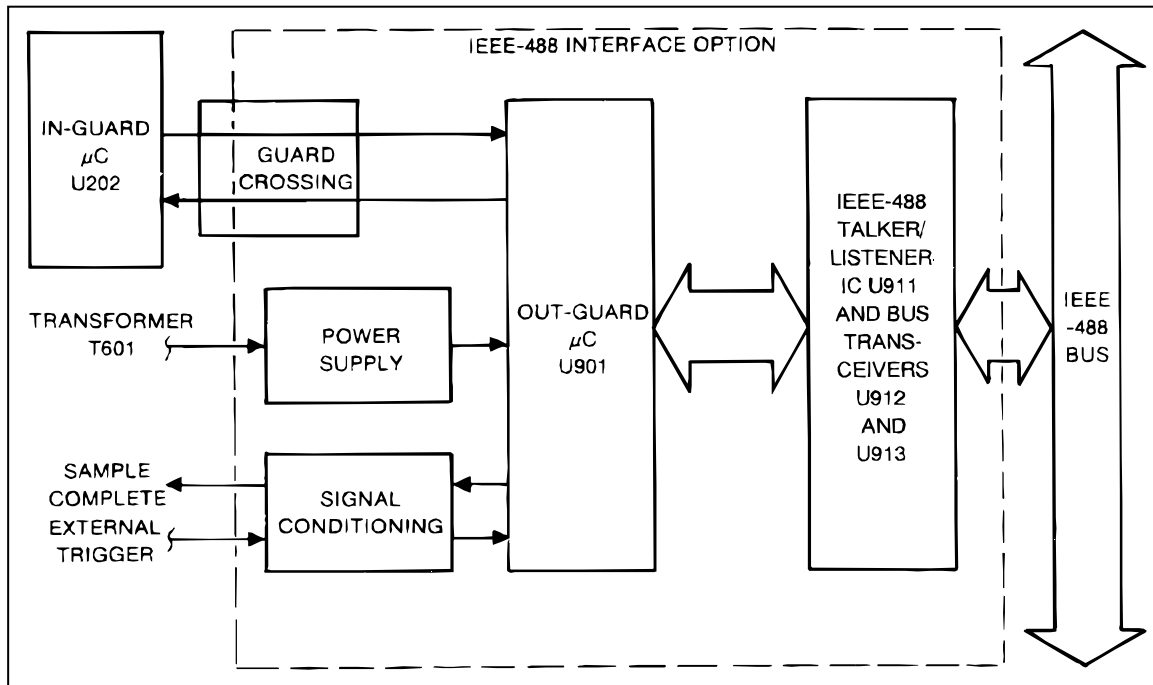

Figure 5-16. IEEE-488 Interface Block Diagram

f5-16.wmf

5-38. Out-Guard Microcomputer

The Out-Guard Microcomputer (μ C) (U901) communicates with the IEEE-488 talker/listener IC (U911) and the In-Guard μ C (U202).

The Out-Guard μ C is similar to the In-Guard Z8 μ C except that it contains 8K bytes of ROM and 236 bytes of RAM. For further description of the Z8 μ C, refer to the heading "In-Guard Microcomputer," above.

5-39. Guard Crossing

The guard crossing circuit permits serial asynchronous communication between U901 and U202 while isolating the two electrically. One-half of the guard crossing circuit is contained on the Main PCA; the other half is on the IEEE-488 Interface PCA. Operation of the guard crossing circuit is described in an earlier heading.

5-40. Bus Interface Circuitry

The IEEE-488 bus protocol is handled by the uPD7210 IEEE-488 talker/listener IC (U911). It is controlled by U901 as a memory mapped peripheral through an 8-bit data bus.

Bus transceivers U912 and U913 buffer U911 from the IEEE-488 bus. They provide the bus with the required output drive capability and receiver impedance.

5-41. Signal Conditioning

The SAMPLE COMPLETE and EXT TRIG signals (J903 and J904) are conditioned by U909. Diodes CR903, CR904, CR905, and CR906 and resistors R917 and R918 provide protection from excessive voltages. Jumpers E902 and E903 allow selection of the polarity of the EXT TRIG signal. (A polarity selection procedure is given in the Maintenance section.) The 8842A is configured in the factory so that it is triggered on the falling edge of the EXT TRIG signal.

5-42. IEEE-488 Interface Power Supply

The IEEE-488 Interface power supply circuit provides the IEEE-488 Interface PCA with +5V. The circuit consists of rectifying diodes CR908 and CR909, filter capacitor C910, and voltage regulator VR901. Power comes from transformer T605 on the Main PCA. U908 and associated circuitry resets the Out-Guard μ C at power-up and following power-line voltage dropouts.

5-43. TRUE RMS AC (OPTION -09)

The True RMS AC circuit (Figure 5-17) performs two primary functions. First, it scales ac input voltages and ac current sense voltages to a range of 0V to 2V ac rms. Second, it converts the scaled ac voltages to an equivalent dc voltage which is then directed to the A/D Converter via the Track/Hold Amplifier. The True RMS AC circuit is trimmed for flat high-frequency response using a variable filter which is set by the High-Frequency AC Calibration procedure.

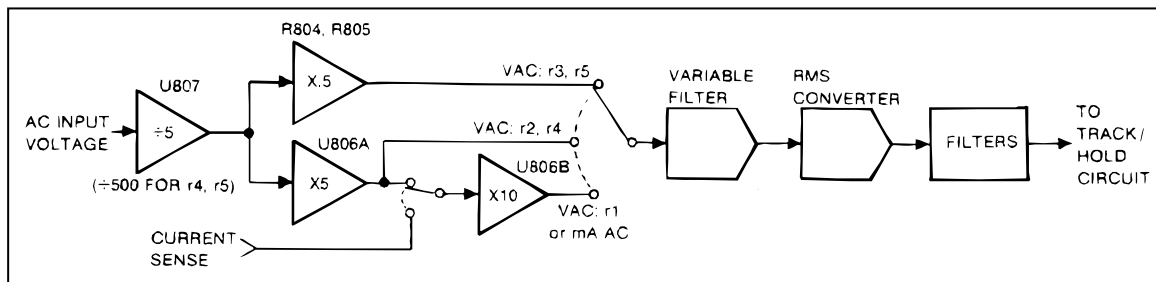

Figure 5-17. True RMS AC Option Block Diagram

fs-17.wmf

The following paragraphs describe how these functions are performed. Components are laid out on a single printed circuit assembly (PCA). Component reference designators are numbered in the 800 series.

5-44. VAC Scaling

AC voltage inputs are directed from the HI INPUT terminal to the True RMS AC PCA through protection resistor R309 on the Main PCA. In this way, voltage transients greater than 1560V are clamped by MOVs (RV301, RV402, RV403, and RV404) as in the VDC function. With the VAC function selected, K801 is closed. The input voltage is thus applied to C801, which blocks dc inputs.

U807 and resistor network Z801 provide selectable attenuation and 1 M Ω input impedance. In the upper two ranges, K802 is closed and Q806 is off, providing a gain of -1/500. In the lower three ranges, K802 is open and Q806 is on, shorting Z801-4 to ground; this configuration provides a gain of -1/5. CR801 and CR802 provide protection by clamping the inverting input of U807 to approximately ± 0.6 V. Q805 shifts logic levels to control Q806.

U806A, U806B, and a voltage divider (R804 and R805) provide gain which is selected for each range by the analog switches in U804. The configuration for each range is shown in Figure 5-17. (In this figure, the CMOS analog switches are represented by mechanical switches.) When U806A is not used, its non-inverting input is grounded by Q804. When U806B is not used, its non-inverting input is connected to the CURRENT SENSE line.

5-45. mA AC Scaling

The mA AC function uses the same current shunt and protection network which is used for dc current. In the mA AC function, Q802 switches the CURRENT SENSE line to the non-inverting input of U806B, which provides a gain of 10.

5-46. Frequency Response Trimming

The frequency response is trimmed by software calibration using a digitally controlled one-pole low-pass filter (R832 and a combination of C826, C827, C828, and C829). The analog switches in U808 configure the four capacitors to select one of 16 possible RC constants. The input of the digitally controlled filter is buffered by voltage follower U801A. The individual gain stages are also provided with fixed frequency compensation.

5-47. True RMS AC-to-DC Conversion

U801B buffers the input to rms converter U802. U802 computes the rms value of the scaled input voltage as shown in Figure 5-18. Rather than explicitly squaring and averaging the input, U802 uses an implicit method in which feedback is used to perform an equivalent analog computation.

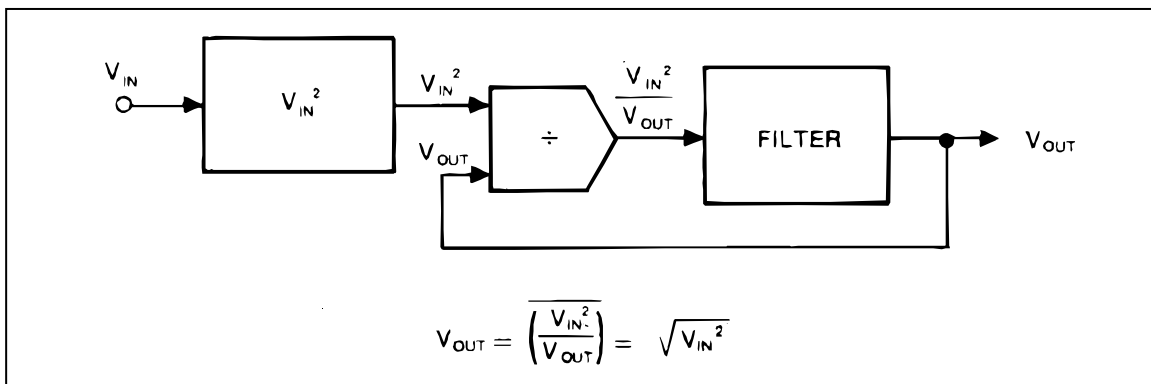

Figure 5-18. True RMS AC-to-DC Converter

f5-18.wmf

The filter averages the divider output signal. This filter consists of U809A, C813, R815, and the internal 25 kΩ resistor and op amp between pins 8 and 9 of U802. The output is further filtered by a three-pole post-filter comprised of U809B and associated resistors and capacitors. This output is then switched into the Track/Hold Amplifier of the dc front end via U302 pins 15 and 14. The Track/Hold Amplifier is set up for unity gain on all ac ranges.



static awareness



A Message From
Fluke Corporation

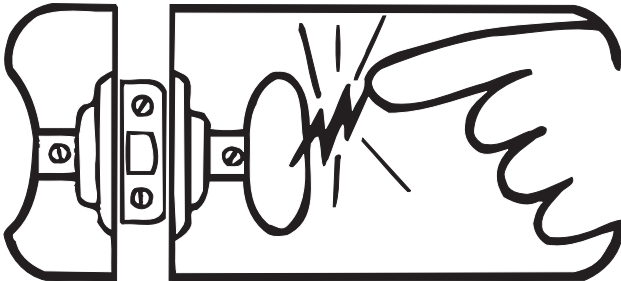

Some semiconductors and custom IC's can be damaged by electrostatic discharge during handling. This notice explains how you can minimize the chances of destroying such devices by:

1. Knowing that there is a problem.
2. Learning the guidelines for handling them.
3. Using the procedures, packaging, and bench techniques that are recommended.

The following practices should be followed to minimize damage to S.S. (static sensitive) devices.

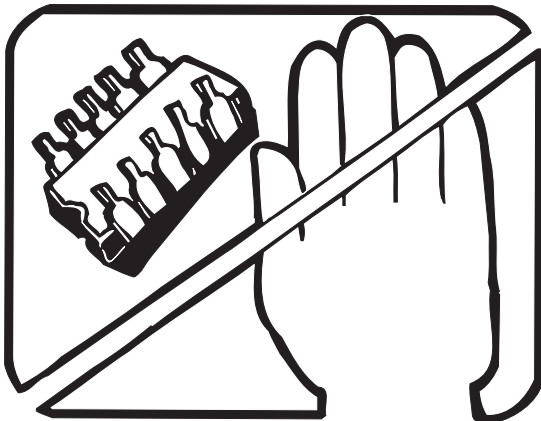

1. MINIMIZE HANDLING

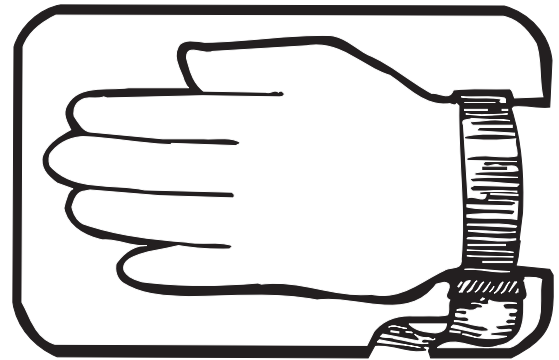

3. DISCHARGE PERSONAL STATIC BEFORE HANDLING DEVICES. USE A HIGH RESISTANCE GROUNDING WRIST STRAP.

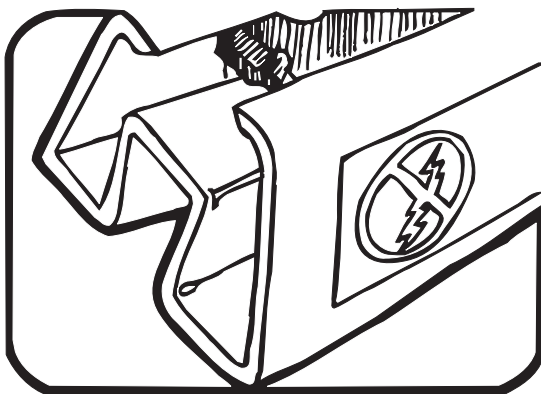

2. KEEP PARTS IN ORIGINAL CONTAINERS UNTIL READY FOR USE.

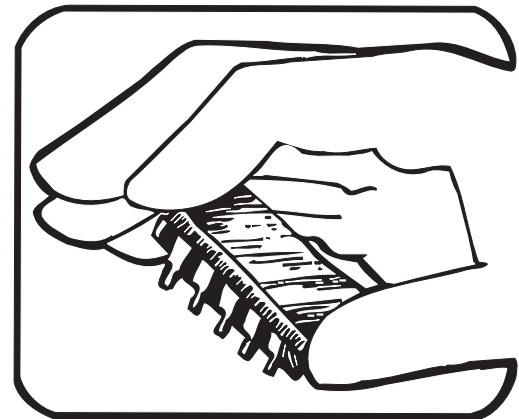

4. HANDLE S.S. DEVICES BY THE BODY.

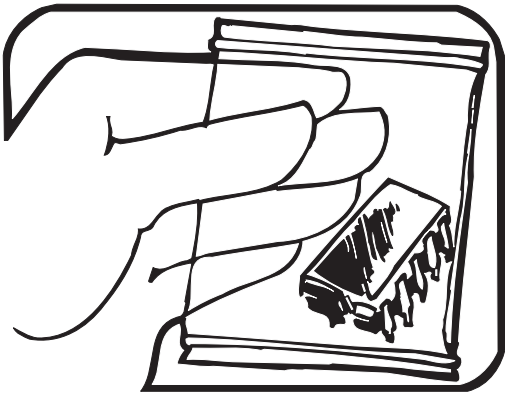

5. USE STATIC SHIELDING CONTAINERS FOR HANDLING AND TRANSPORT.

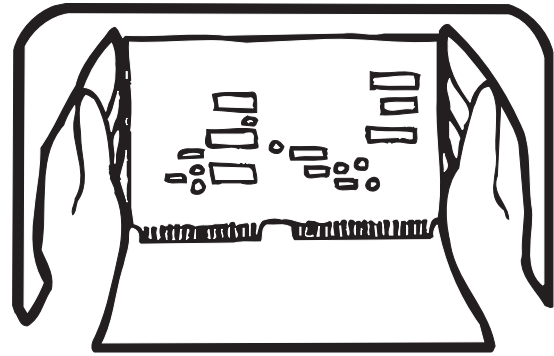

8. WHEN REMOVING PLUG-IN ASSEMBLIES HANDLE ONLY BY NON-CONDUCTIVE EDGES AND NEVER TOUCH OPEN EDGE CONNECTOR EXCEPT AT STATIC-FREE WORK STATION. PLACING SHORTING STRIPS ON EDGE CONNECTOR HELPS PROTECT INSTALLED S.S. DEVICES.

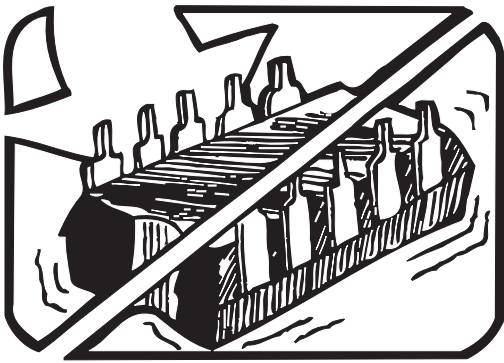

6. DO NOT SLIDE S.S. DEVICES OVER ANY SURFACE.

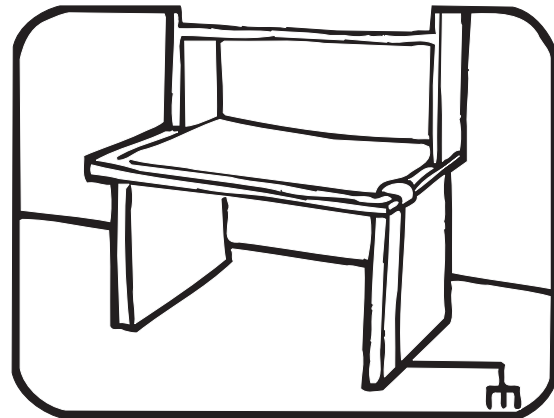

9. HANDLE S.S. DEVICES ONLY AT A STATIC-FREE WORK STATION.

10. ONLY ANTI-STATIC TYPE SOLDER-SUCKERS SHOULD BE USED.

11. ONLY GROUNDED-TIP SOLDERING IRONS SHOULD BE USED.

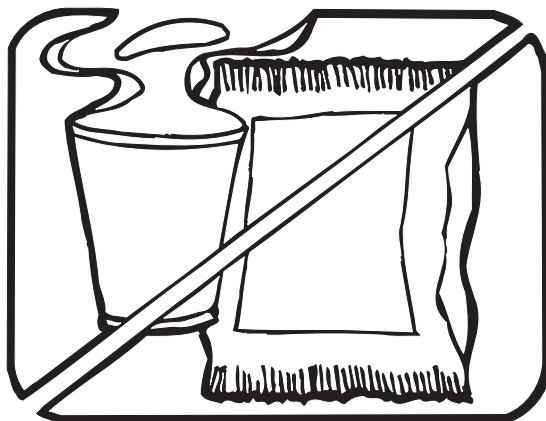

7. AVOID PLASTIC, VINYL AND STYROFOAM® IN WORK AREA.

PORTIONS REPRINTED
WITH PERMISSION FROM TEKTRONIX INC.
AND GERNER DYNAMICS, POMONA DIV.

Chapter 6

Maintenance

	Title	Page
6-1.	INTRODUCTION	6-3
6-2.	PERFORMANCE TEST	6-4
6-3.	Diagnostic Self-Tests	6-4
6-4.	DC Voltage Test.....	6-5
6-5.	AC Voltage Test (Option -09 Only).....	6-7
6-6.	Resistance Test.....	6-8
6-7.	DC Current Test	6-9
6-8.	AC Current Test (Option -09 Only)	6-10
6-9.	CALIBRATION	6-10
6-10.	Basic Calibration Procedure.....	6-11
6-11.	INITIAL PROCEDURE	6-11
6-12.	A/D CALIBRATION	6-12
6-13.	OFFSET AND GAIN CALIBRATION	6-14
6-14.	HIGH-FREQUENCY AC CALIBRATION.....	6-15
6-15.	Advanced Features and Special Considerations.....	6-16
6-16.	STORING VARIABLE INPUTS	6-16
6-17.	CALIBRATING INDIVIDUAL RANGES.....	6-17
6-18.	VERIFYING CALIBRATION.....	6-17
6-19.	ERASING CALIBRATION MEMORY	6-18
6-20.	TOLERANCE CHECK	6-18
6-21.	AC CALIBRATION AT OTHER FREQUENCIES	6-19
6-22.	OPTIMIZING USE OF THE 5450A.....	6-19
6-23.	Remote Calibration	6-20
6-24.	TIMING CONSIDERATIONS	6-23
6-25.	REMOTE ERASURE.....	6-24
6-26.	EXAMPLE CALIBRATION PROGRAM.....	6-24
6-27.	DISASSEMBLY PROCEDURE.....	6-25
6-28.	Case Removal.....	6-26
6-29.	True RMS AC PCA Removal (Option -09 Only)	6-30
6-30.	IEEE-488 Interface PCA Removal (Option -05 Only)	6-30
6-31.	Main PCA Removal	6-30
6-32.	Front Panel Disassembly.....	6-32
6-33.	REASSEMBLY PROCEDURE	6-32
6-34.	INTERNAL FUSE REPLACEMENT	6-36

6-35.	EXTERNAL TRIGGER POLARITY SELECTION (Option -05 Only)	6-36
6-36.	TROUBLESHOOTING	6-36
6-37.	Initial Troubleshooting Procedure.....	6-36
6-38.	Diagnostic Self-Tests	6-41
6-39.	Self-Test Descriptions	6-42
6-40.	Digital Controller Troubleshooting	6-45
6-41.	IN-GUARD MICROCOMPUTER SYSTEM	6-45
6-48.	DISPLAY SYSTEM.....	6-48
6-59.	ANALOG CONTROL SIGNALS	6-51
6-62.	DC Scaling Troubleshooting.....	6-54
6-63.	Track/Hold Troubleshooting	6-56
6-64.	Ohms Current Source Troubleshooting.....	6-56
6-65.	Precision Voltage Reference Troubleshooting.....	6-58
6-66.	A/D Converter Troubleshooting.....	6-59
6-67.	Power Supply Troubleshooting.....	6-61
6-68.	IEEE-488 Interface Troubleshooting (Option -05)	6-64
6-69.	SERVICE POSITION.....	6-64
6-70.	DIAGNOSTIC PROGRAM	6-64
6-71.	True RMS AC Troubleshooting (Option -09).....	6-66
6-72.	SERVICE POSITION.....	6-66
6-73.	MAJOR PROBLEMS.....	6-67
6-74.	MORE OBSCURE PROBLEMS	6-69
6-75.	Guard Crossing Troubleshooting	6-70
6-76.	INTERNAL CLEANING.....	6-70
6-77.	Cleaning Printed Circuit Assemblies	6-70
6-78.	Cleaning After Soldering	6-71

WARNING

THESE SERVICE INSTRUCTIONS ARE FOR USE BY QUALIFIED PERSONNEL ONLY. TO AVOID ELECTRIC SHOCK, DO NOT PERFORM ANY PROCEDURES IN THIS SECTION UNLESS YOU ARE QUALIFIED TO DO SO.

6-1. INTRODUCTION

This section presents maintenance information for the 8842A. The section includes a performance test, a calibration procedure, troubleshooting information, and other general service information.

Test equipment recommended for the performance test and calibration procedure is listed in Table 6-1. If the recommended equipment is not available, equipment that meets the indicated minimum specifications may be substituted.

Table 6-1. Recommended Test Equipment

INSTRUMENT TYPE	MINIMUM SPECIFICATIONS	RECOMMENDED MODEL
DC Calibrator	PREFERRED: Voltage Range: 0-1000V dc Voltage Accuracy: 10 ppm Absolute Linearity: ± 1.0 ppm	Fluke 5700A or Fluke 5440A
	ALTERNATIVE: (Must be used with Kelvin-Varley Voltage Divider) Voltage Range: 0-1000V dc Voltage Accuracy: 20 ppm + 20 ppm of range	Fluke 720A
	Kelvin-Varley Voltage Divider: Ratio Range: 0-1.0 Absolute Linearity: ± 1 ppm of input at dial setting	Fluke 720A
Resistor Calibrator	Resistance Accuracy: 0.0005%	Fluke 5700A or Fluke 5450A, ESI DB62
DC Current Source	Accuracy: $\pm 0.025\%$	Fluke 5700A or Fluke 5100B
Oscilloscope	General purpose, 60 MHz, with 10 M Ω probe	Philips PM3055 or PM3355
Digital Multimeter	Voltage Accuracy :0.01% in V dc 1.0% for 1V in V ac @ 100 kHz Input Impedance: 10 M Ω or greater in V dc; 1 M Ω or greater in parallel with <100 pF in V ac	Fluke 8842A (with AC Option -09)

AC Calibrator

Fluke 5700A and Fluke 5725A

Minimum Required Accuracy (By Range)			
Frequency Range	1, 10, 100 mV ¹	1, 10, 100V ²	1000V ²
20 Hz – 30 Hz	.1 + .005	.1 + .005	.12 + .005
30 Hz – 20 kHz	.02 + 10	0.2 + .002	.04 + .004
20 kHz – 50 kHz	.05 + 20	.05 + .005	.08 + .005
50 kHz – 100 kHz	.05 + 20	.05 + .005	.1 + .01

1. \pm (% of setting + μ V) 2. \pm (% of setting + % of range)

AC Current Source

Fluke 5700A

Frequency Range	Minimum Required Accuracy (All Ranges)
30 Hz – 1 kHz	\pm .07% + 1 mA)
1kHz – 5 kHz	\pm (.07% + 1 mA) X frequency in kHz

Shorting Bar	Resistance <1.5 m Ω Construction Soldered (not rivetted)	Pomona MDP-S-0
6-Inch Jumper	----	E-Z-Hook 204-6W-S or equivalent
Optional Test Equipment	9010A, 9005A or Micro-System Troubleshooter; 9000A-8048 Interface Pod.	

6-2. PERFORMANCE TEST

This test compares the performance of the 8842A with the specifications given in Section 1. The test is recommended as an acceptance test when the instrument is first received, and as a verification test after performing the calibration procedure. If the instrument does not meet the performance test, calibration or repair is needed.

To ensure optimum performance, the test must be performed at an ambient temperature of 18°C to 28°C, with a relative humidity of less than 75%. Also, the 8842A should be allowed to warm up for one hour prior to beginning any test other than the self-test.

6-3. Diagnostic Self-Tests

The diagnostic self-tests check the analog and digital circuitry in the 8842A. There are 21 analog tests followed by in-guard program memory, calibration memory, and display tests. Out-guard program memory is tested when self-test is initiated by a remote command. Microcomputer RAM tests are done only at powerup. Each test is described in detail under the heading Troubleshooting. All five digital tests are performed at powerup.

NOTE

The inputs must be left open-circuited while the self-tests are performed. Otherwise, the 8842A may indicate errors are present. Errors may also be caused by inductive or capacitive pick-up from long test leads.

If the FRONT/REAR switch is in the REAR position, the 8842A skips tests 3 and 4. Also, if Option -09 is not installed, the 8842A skips tests 1, 2, and 3.

To initiate the self-tests, press the SRQ button for 3 seconds. The TEST annunciator will then light up, and the 8842A will run through the analog tests in sequence. Each test number is displayed for about 1 second. The instrument can be stopped in any of the test configurations by pressing the SRQ button while the test number is displayed. Pressing any button continues the tests.

After the last analog test is performed, all display segments light up while the instrument performs the in-guard program memory, calibration memory, and display tests. The instrument then assumes the power-up configuration: VDC, autorange, slow reading rate, offset off, local control.

If the 8842A detects an error during one of the tests, it displays the ERROR annunciator and the test number for about 2-1/2 seconds, and then proceeds to the next test. The test number thus becomes an error code. (Error codes are listed in Table 2-1, Section 2.)

Passing all diagnostic self-tests does not necessarily mean the 8842A is 100% functional. The test, for example, cannot check the accuracy of the analog circuitry. If one or more errors are displayed, the 8842A probably requires service.

6-4. DC Voltage Test

The following procedure may be used to verify the accuracy of the VDC function:

1. Ensure the 8842A is on and has warmed up for at least 1 hour.
2. Select the VDC function.
3. Connect the DC Calibrator (see Table 6-1) to provide a voltage input to the HI and LO INPUT terminals. Connections for the Kelvin-Varley Voltage Divider and the Fluke 5440A are shown in Figure 6-1.
4. For each step in Table 6-2, select the indicated range, set the DC Calibrator for the specified input, and verify that the displayed reading is within the limits shown for each reading rate. (For step A, connect a short across the HI and LO INPUT terminals and press OFFSET. The measurement in step C should be relative to this offset.)
5. Set the DC Calibrator to input negative voltage, and repeat steps C through G of Table 6-2.
6. With the unit in the 2V range, check the A/D linearity by setting the DC Calibrator for each step in Table 6-9, while verifying the display reading is within the limit shown. Set the DC Calibrator for zero volts and disconnect it from the 8842A.

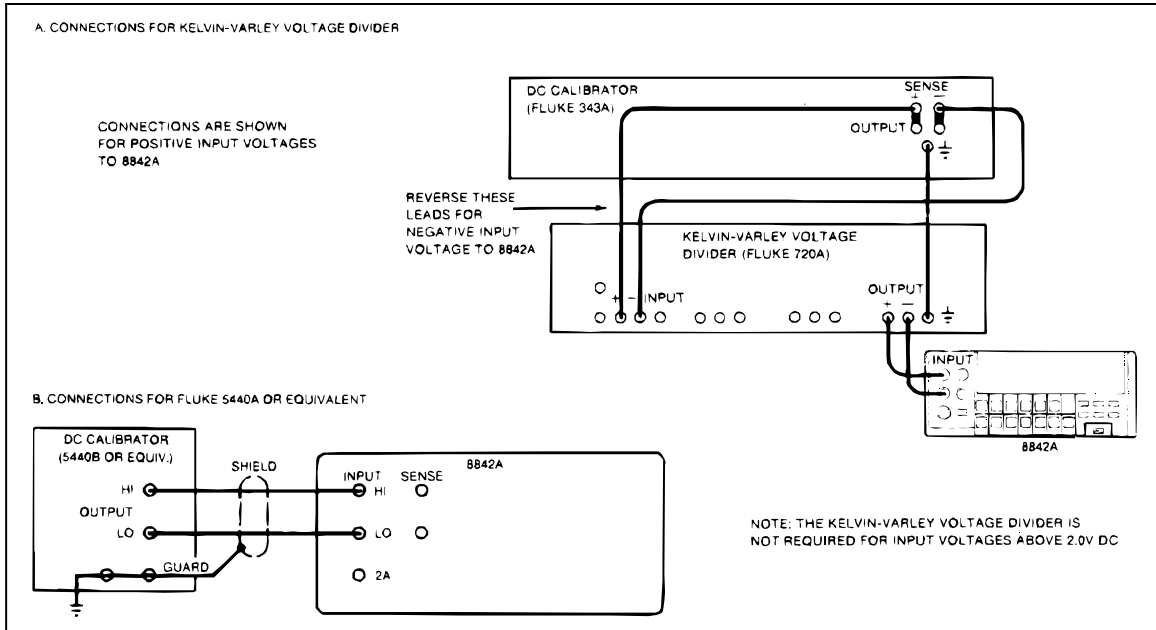

f6-01.wmf

Figure 6-1. DC Calibration Connections

Table 6-2. DC Voltage Test

STEP	RANGE	INPUT (V dc)	Displayed Reading					
			SLOW		MEDIUM		FAST	
			MIN	MAX	MIN	MAX	MIN	MAX
A ¹	20 mV	0V (short)	-0.0030	+0.0030	-0.0050	+0.0050	-0.030	+0.030
B ¹	200 mV	0V (short)	-00.003	+00.003	-00.005	+00.005	-00.03	+00.03
C ¹	2V, 20V, 200V, 1000V	0V (short)	-2 counts	+2 counts	-4 counts	+ 4 counts	-3 counts	+3 counts
D	20 mV	10 mV	+9.9963	+10.0037	+9.9943	+10.0057	+9.970	+10.030
E	200 mV	100 mV	+99.993	+100.007	+99.991	+100.009	+99.97	+100.03
F	2V	1V	+99996	+1.00004	+99994	+1.00006	+9997	+1.0003
G	20V	10V	+9.9995	+10.0005	+9.9993	+10.0007	+9.997	+10.003
H	200V	100V	+99.995	+100.005	+99.993	+100.007	+99.97	+100.03
I	1000V	1000V	+999.95	+1000.05	+999.93	+1000.07	+999.7	+1000.3

1. Relative to high-quality short stored using OFFSET feature.

6-5. AC Voltage Test (Option -09 Only)

The following procedure may be used to verify the accuracy of the VAC function:

1. Ensure the 8842A is on and warmed up for at least 1 hour.
2. Select the VAC function and the slow (S) reading rate.
3. Connect the AC Calibrator to provide a voltage input to the HI and LO INPUT terminals.
4. (Low- and Mid-Frequency Test.) For each step in Table 6-3, select the indicated range, set the AC Calibrator for the specified input, and verify that the displayed reading is within the limits shown for each reading rate.

NOTE

This procedure tests the extremes of each range. You may shorten the procedure by testing only the "quick test points" indicated in Table 6-3 with asterisks.

5. (High-Frequency Test.) For each step in Table 6-4, select the indicated range, set the AC Calibrator for the specified input, and verify that the displayed reading is within the limits shown for each reading rate.

NOTE

This procedure tests the extremes of each range. You may shorten the procedure by testing only the "quick test points" indicated in Table 6-4 with asterisks.

6. Set the AC calibrator to standby and disconnect it from the 8842A.

Table 6-3. Low- and Mid-Frequency AC Voltage Test

Step Number	Range	Input		Error in Counts	Display Readings	
		Voltage	Frequency		Minimum	Maximum
1	2V	0.01000V	200 Hz	181	0.00819 VAC	0.01181 VAC
2	2V	0.10000V	200 Hz	87	.09913 VAC	.10087 VAC
3*	2V	0.30000V	200 Hz	101	0.29899 VAC	0.30101 VAC
4	2V	1.00000V	200 Hz	150	0.99850 VAC	1.00150 VAC
5*	2V	1.90000V	200 Hz	213	1.89787 VAC	1.90213 VAC
6	2V	0.10000V	20 Hz	220	0.09780 VAC	0.10220 VAC
7	2V	1.90000V	20 Hz	2380	1.87620 VAC	1.92380 VAC
8	2V	.10000V	45 Hz	135	0.09865 VAC	0.10135 VAC
9	2V	1.90000V	45 Hz	765	1.89235 VAC	1.90765 VAC
10*	200 mV	0.001000V	100 Hz	204	00.796 mVAC	190.252 mVAC
11	200 mV	0.190000V	20 kHz	252	189.748 mVAC	190.252 MvAC

* Quick Test points

Table 6-4. High-Frequency AC Voltage Test

STEP NUMBER	RANGE	INPUT		ERROR IN COUNTS	TEST LIMITS (IN VOLTS)	
		VOLTAGE	FREQUENCY		MIN	MAX
1	200 mV	0.010000V	50 kHz	169	09.831 mVAC	10.169 mVAC
2 *	200 mV	0.010000V	100 kHz	350	09.650 mVAC	10.350 mVAC
3 *	2V	0.10000V	100 kHz	350	0.09650 VAC	0.10350 VAC
4 *	20V	1.0000V	100 kHz	350	0.9650 VAC	1.0350 VAC
5 *	200V	10.000V	100 kHz	350	09.650 VAC	10.350 VAC
6 *	700V	100.00V	100 kHz	350	96.50 VAC	103.50 VAC
7	20V	19.0000V	100 kHz	1250	18.8750 VAC	19.1250 VAC
8	200 mV	0.190000V	100 kHz	1250	188.750 mVAC	191.250 mVAC

* Quick test points.

6-6. Resistance Test

The following procedure may be used to verify the accuracy of the 2-wire and 4-wire ohms functions.

1. Ensure the 8842A is on and has warmed up for at least 1 hour.
2. Connect the Resistance Calibrator to the 8842A for 4-wire ohms.
3. For each step in Table 6-5, select the indicated range, set the Resistance Calibrator for the specified nominal input. When the input is 0Ω (short), press the OFFSET switch and verify that the OFFSET annunciator is illuminated.

NOTE

A new OFFSET must be stored for each new range selected.

- a. Test the 4-wire ohms function:
 1. Select the 4-wire ohms function.
 2. Verify that the displayed reading is within the limits shown for each reading rate.
- b. Test the 2-wire ohms function:
 1. Select the 2-wire ohms function. (The SENSE test leads need not be disconnected.)
 2. Verify that the displayed reading is within the limits shown for each reading rate.

Table 6-5. Resistance Test

Step	Range	Input (Nominal)	Error From Input ¹ (in counts)		
			Slow	Medium	Fast ²
1	20Ω ³	0Ω (short)	±40	±60	±20
2	20Ω ³	10Ω	±49	±69	±21
3	200Ω ³	0Ω (short)	±4	±6	±3
4	200Ω ³	100Ω	±11	±13	±4
5	2 kΩ	0Ω (short)	±3	±5	±2
6	2 kΩ	1 kΩ	±8	±10	±3
7	20 kΩ	0Ω (short)	±3	±5	±2
8	20 kΩ	10 kΩ	±8	±10	±3
9	200 kΩ	0Ω (short)	±3	±5	±2
10	200 kΩ	100 kΩ	±9	±11	±3
11	2000 kΩ	0Ω (short)	±3	±6	±2
12	2000 kΩ	1 MΩ	±28	±31	±5
13	20 MΩ	0Ω (short)	±4	±7	±2
14	20 MΩ	10 MΩ	±44	±47	±6

1 – Using offset control
2 = 4 ½ digit counts
3 = Applies to 4-wire ohms only

6-7. DC Current Test

The following procedure may be used to test the mA DC function:

1. Ensure the 8842A is on and has warmed up for at least 1 hour.
2. Select the mA DC function.
3. Connect the Current Source to the 2A and LO INPUT terminals.
4. For each step in Table 6-6, set the Current Source for the indicated input and verify that the displayed reading is within the limits shown for each reading rate.
5. Set the Current Source for zero mA and disconnect it from the 8842A.

Table 6-6. DC Current Test

STEP	RANGE	INPUT	DISPLAYED READING					
			SLOW		MEDIUM		FAST	
			MIN	MAX	MIN	MAX	MIN	MAX
1	200 mA	0 mA	-00.040	+00.040	-00.060	+00.060	-00.20	+00.20
2	200 mA	100 mA	99.920	100.080	99.900	100.100	99.76	100.24
3	2000 mA	0 mA	-000.04	+000.04	-000.06	+000.06	-000.2	+000.2
4	2000 mA	1000 mA	999.56	1000.44	999.54	1000.46	999.4	1000.6

6-8. AC Current Test (Option -09 Only)

The following procedure may be used to test the mA AC function:

1. Ensure the 8842A is on and warmed up for at least 1 hour.
2. Select the mA AC function.
3. Connect the AC Current Source to provide a current input to the 2A and LO INPUT terminals. If an ac current source is not available, the functionality of the 8842A can be checked at 10 mA by using a Fluke 5200A set at 100V and connected to the 8842A 2A terminal through a 10 k Ω , 2W, 1% resistor.
4. For each step in Table 6-7, set the AC Current Source for the indicated input and verify that the displayed reading is within the limits shown for each reading rate.
5. Set the AC Current Source to Standby and disconnect it from the 8842A.

Table 6-7. AC Current Test

STEP NUMBER	RANGE	INPUT		TEST LIMITS	
		CURRENT	FREQUENCY	MINIMUM	MAXIMUM
1	2000 mA	1900.00 mA	1 kHz	1890.40	1909.60
2	2000 mA	100.00 mA	1 kHz	97.60	102.40

6-9. CALIBRATION

CAUTION

To avoid uncalibrating the 8842A, never cycle power on or off while the CAL ENABLE switch is on.

NOTE

If U220 is replaced, perform the Erase Cal Memory procedure (located later in this section) before attempting calibration. Failure to do so may result in an "ERROR 29" on the 8842A front panel display.

The 8842A features closed-case calibration using known reference sources. The 8842A automatically prompts you for the required reference sources, measures them, calculates correction factors, and stores the correction factors in the nonvolatile calibration memory.

Closed-case calibration has many advantages. There are no parts to disassemble, no mechanical adjustments to make, and if the IEEE-488 Interface is installed, the 8842A can be calibrated by an automated instrumentation system.

The 8842A should normally be calibrated on a regular cycle, typically every 90 days or 1 year. The frequency of the calibration cycle depends on the accuracy specification you wish to maintain. The 8842A should also be calibrated if it fails the performance test or has undergone repair. To meet the specifications in Section 1, the 8842A should be calibrated with equipment meeting the minimum specifications given in Table 6-1.

The following paragraphs first present a basic calibration procedure. This is followed by a description of advanced features and special considerations, and by a description of remote calibration using the IEEE-488 Interface.

6-10. Basic Calibration Procedure

The basic calibration procedure consists of the following four parts. These parts must be performed in the order shown.

1. Initial Procedure.
2. A/D Calibration.
3. Offset and Gain Calibration for each function and range.
4. High-Frequency AC Calibration (True RMS AC option only).

Normally, it is recommended that the entire calibration procedure be performed. However, under some circumstances the earlier parts may be omitted. For example, if installing the True RMS AC option, it may be necessary only to perform Offset and Gain Calibration for the ac functions, followed by High-Frequency AC Calibration. But if the A/D Calibration is performed, it must be followed by a complete Offset and Gain Calibration for all functions and then by High-Frequency AC Calibration.

Some of the calibration calculations are complex and take the 8842A some time to execute. For example, when you store the zero input during the Offset and Gain Calibration for the VDC function, it takes around 22 seconds before the next prompt appears. (The 8842A automatically uses this input to calibrate the offset for all ranges.) While the 8842A is executing a calibration step, it ignores all of the front panel buttons and postpones execution of all remote commands.

6-11. INITIAL PROCEDURE

Always begin the calibration procedure as follows:

1. Allow the 8842A to stabilize in an environment with ambient temperature of 18°C to 28°C and relative humidity less than 75%.
2. Turn the 8842A on and allow it to warm up for at least 1 hour.
3. Enable the calibration mode by pressing the CAL ENABLE switch with a small screw-driver or other suitable instrument. (The CAL ENABLE switch is located on the right side of the display and is normally covered by a calibration seal.)

When the calibration mode is enabled, the CAL annunciator lights up, and the 8842A displays the first prompt for the A/D Calibration procedure (Figure 6-2). To exit the calibration mode, press the CAL ENABLE switch again.

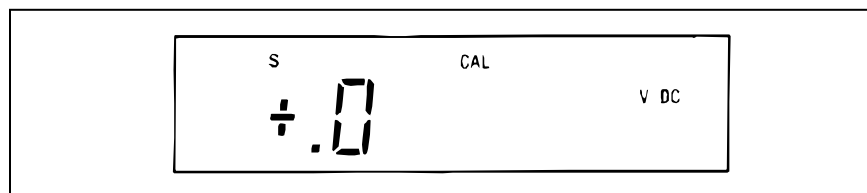
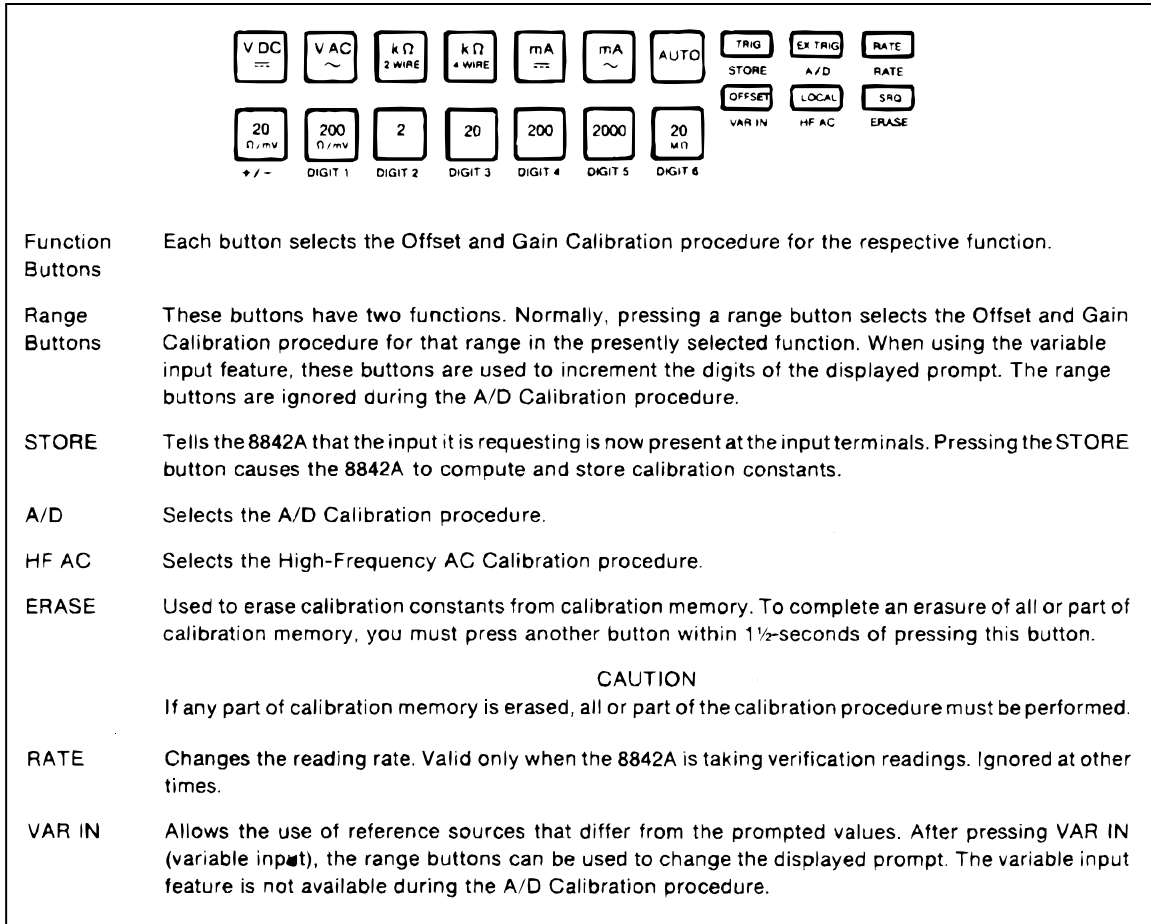

Figure 6-2. First A/D Calibration Prompt

f6-02.wmf

In the calibration mode, the front panel controls assume the functions described in Figure 6-3. Some of these functions are advanced features and are not required for the basic calibration procedure. The display blanks briefly when a button is pressed.



16-03.wmf

Figure 6-3. Calibration Functions

The following functions are inappropriate during calibration, and are therefore unavailable:

- Offset
- Autoranging
- External Trigger
- Front Panel Trigger
- Front panel SRQ (Under local control)
- Diagnostic self-tests

6-12. A/D CALIBRATION

The A/D Calibration procedure calibrates the analog-to-digital converter for offset, gain and linearity. The 8842A automatically selects the A/D calibration procedure when the CAL ENABLE switch is first pressed. The procedure must be performed in its entirety, and may not be performed in part. If the A/D calibration is discontinued prior to completion, the last complete set of A/D calibration constants will be retained unchanged.

To perform A/D Calibration, proceed as follows:

1. Ensure the Initial Procedure has been completed. The 8842A then displays the prompt for the first reference source, zero volts (i.e., a short).

2. Each time the 8842A prompts you for a reference source, apply the requested source to the HI and LO INPUT terminals, and press the STORE button. When STORE is pressed, the numeric display field blanks while the 8842A performs the necessary calculations. (Do not change the reference source while the display is blank.) The 8842A then displays the next prompt. For reference, all prompts are shown in Table 6-8.

NOTE

The 8842A automatically checks that the reference input is near the value prompted, and displays ERROR 41 if it exceeds a specific tolerance. (See Advanced Features and Special Considerations, later in this section.)

3. After the last input is stored, the 8842A begins taking readings in the 2V range of the VDC function. (The CAL annunciator remains on.) Verify the A/D calibration using the test points in Table 6-9. If you wish to repeat the A/D Calibration procedure, press the A/D button.

Table 6-8. A/D Calibration Steps

STEP	DISPLAYED PROMPT
A	.0 V DC (short)
B	- .03 V DC
C	- 1.01 V DC
D	+ .99 V DC
E	+ .51 V DC
F	- .51 V DC
G	- .26 V DC
H	+ .26 V DC
I	+ .135 V DC
J	- .135 V DC
K	- .0725 V DC
L	+ .0725 V DC

Table 6-9. A/D Calibration Verification Test

STEP	INPUT	ALLOWABLE ERROR
A	0V (short)	±2 counts
B	-0.03V	±2 counts
C	+0.03V-0.660V	±2 counts
D	-0.660V	±3 counts
E	+0.660V	±3 counts
F	-1.970V	±4 counts
G	+1.970V	±4 counts

The A/D Calibration procedure is an iterative process. Each pass through the procedure uses the constants stored previously and improves them. Normally, one pass is adequate. However, if the calibration memory has been erased or replaced, or the A/D Converter has undergone repair, the A/D Calibration procedure must be performed twice.

Because the A/D Calibration procedure is iterative, the instrument's performance can be slightly enhanced by going through the procedure more than twice. However, this is not necessary to meet the published specifications.

6-13. OFFSET AND GAIN CALIBRATION

This procedure calibrates the instrument's offsets and gains by applying a high and low input for every range of each function. To save time, the 8842A uses each input for as many ranges as possible.

A function is calibrated by pressing the corresponding function button. Once a function is selected, the 8842A automatically steps through each range of that function, prompting you for the necessary reference sources. (The prompts are shown in Table 6-10.) The 8842A does not automatically select another function after one function has been completely calibrated; therefore, the functions may be calibrated in any order.

To perform Offset and Gain Calibration, proceed as follows:

Table 6-10. Offset and Gain Calibration Steps

STEP	DISPLAYED PROMPT				
	VDC	VAC ¹	2 WIRE kΩ 4 WIRE kΩ	mA DC	mA AC ¹
A	+00.0 mV DC (short)	10.0 mV AC	0.00Ω (short)	00.0 mA DC (open)	100 mA AC
B	+19.0 mV DC	--	10.0Ω (4 wire)	100 mA DC	--
C	+190.0 mV DC	100.0 mV AC	100.0Ω	1000. mA DC	1000.0 mA AC
D	+1.900 V DC	1.000 V AC	1.000 kΩ	Steps D-H not applicable for these functions.	
E	+19.00 V DC	10.00 V AC	10.00 kΩ		
F	+190.0 V DC	100.0 V AC	100.0 kΩ		
G	+1000. V DC	500. V AC	1000. kΩ		
H	Step H not applicable for these functions.		10.00 MΩ		

¹ Inputs should be at 1 kHz +/-10%. Performance may be enhanced for specific frequencies (see text).

1. Ensure the A/D Calibration procedure has been completed.
2. Select the desired function by pressing the corresponding function button. The 8842A will display the first prompt for that function.
3. Each time the 8842A prompts you for a reference source, apply this source to the appropriate terminals, and press the STORE button. When STORE is pressed, the numeric display field blanks while the 8842A performs the necessary calculations. (Do not change the reference source while the display is blank.) The 8842A then displays the next prompt. For reference, all prompts are shown in Table 6-10.

NOTE

To use reference sources that differ from the prompted values, see Storing Variable Inputs later in this section.

4. After the last range is calibrated, the 8842A begins taking readings in the highest range so that you may verify its calibration. (The CAL annunciator remains on.) To verify the calibration for the other ranges, press the corresponding range button. (Pressing a function button begins the Offset and Gain Calibration procedure for that function.)
5. Repeat steps 2, 3, and 4 for the remaining functions. Note that both 2-wire and 4-wire ohms functions must be calibrated. (The VAC and mA AC functions require calibration only if the True RMS AC option is installed.)

NOTE

(True RMS AC option only.) The VAC and mA AC functions should normally be calibrated using reference sources at 1 kHz (+/-10%). For special applications, performance may be optimized at other frequencies. See Optimizing AC Calibration at Other Frequencies, later in this section.

6. When all functions have been calibrated, exit the calibration mode by pressing the CAL ENABLE switch and attach a calibration certification sticker over the CAL ENABLE switch. (If the True RMS AC option is installed, instead proceed to the High-Frequency AC Calibration procedure which follows.)

6-14. HIGH-FREQUENCY AC CALIBRATION

The High-Frequency AC Calibration procedure calibrates the response of the VAC function from 20 kHz to 100 kHz. If the True RMS AC option is not installed, selecting this procedure results in an error message.

The reference sources used in this procedure should normally be between 90 kHz and 100 kHz. 100 kHz (nominal) is recommended. For special applications, performance may be optimized at other frequencies. See Optimizing AC Calibration at Other Frequencies, later in this section.

To perform High-Frequency AC Calibration, proceed as follows:

1. Ensure Offset and Gain Calibration has been completed for the VAC function.
2. Select the High-Frequency AC Calibration procedure by pressing the HF AC button. The 8842A will display the first prompt (100 mV AC). The "U" in the display indicates the High-Frequency AC Calibration procedure has been selected.
3. Each time the 8842A prompts you for a reference amplitude, apply this amplitude to the HI and LO INPUT terminals, and press the STORE button. When STORE is pressed, the numeric display field blanks while the 8842A performs the necessary calculations. (Do not change the reference source while the display is blank.) The 8842A then displays the next prompt. For reference, all prompts are shown in Table 6-11.

NOTE

To use reference amplitudes that differ from the prompted values, see Storing Variable Inputs later in this section.

4. After the last range is calibrated, the 8842A begins taking readings in the highest range so that you may verify its calibration. To verify the calibration for the other ranges, push the corresponding range button. The CAL annunciator remains on.

5. The calibration procedure is now completed. Exit the calibration mode by pressing the CAL ENABLE switch, and attach a calibration certification sticker over the CAL ENABLE switch.

6-15. *Advanced Features and Special Considerations*

Table 6-11. High-Frequency AC Calibration Steps

STEP	DISPLAYED PROMPT ^{1,2}
A	100.0 mV AC
B	1.000 V AC
C	10.00 V AC
D	100.0 V AC
E	200.0 V AC

1. The display also indicates "U" to show that HF AC cal is selected.
2. Inputs should be between 90 kHz and 100 kHz. (nominal) is recommended.

The 8842A has several advanced calibration features which are not necessary for the basic calibration procedure, but which can make calibration easier. The following paragraphs describe these features and also discuss special considerations for optimizing the performance of the 8842A in special situations.

6-16. *STORING VARIABLE INPUTS*

As a convenience, the VAR IN (variable input) feature lets you calibrate the 8842A using reference source values which differ from the values prompted by the 8842A. For example, you may want to calibrate the 200Ω range using a reference resistor with a precisely known value of 99.875Ω, rather than 100Ω as prompted. This feature is not available during A/D Calibration.

To use the variable input feature, proceed as follows:

1. When the 8842A prompts you for an input, press the VAR IN button. The blank digits will be replaced with zeroes. You can then increment each digit of the display by pressing the range buttons. The 20Ω/mV button toggles the displayed sign.
2. Change the displayed prompt to correspond to the desired reference source by pressing the appropriate range buttons.
3. Connect the desired reference source to the appropriate input terminals of the 8842A.
4. Press the STORE button.

To meet the specifications over all ranges, the reference source for the high prompts must be between half and full scale. (The high prompts are those prompts that are between 50% and 100% of full scale.) The reference source for the low prompts must be equal to or greater than the prompted value, but not more than that value plus 4000 counts. (The low prompts are those prompts that are zero or 5% of full scale.)

For special applications, the 8842A can be calibrated at values outside the recommended range. This can enhance the performance at the calibration value. However, performance at other values may be degraded.

6-17. CALIBRATING INDIVIDUAL RANGES

During Offset and Gain and High-Frequency AC Calibration, it is possible to calibrate individually selected ranges. This feature does not apply to the mA DC and mA AC functions and is not permitted during A/D Calibration.

To calibrate an individual range, proceed as follows:

1. Select the desired calibration procedure by pressing the appropriate function button (or press the HF AC button if High-Frequency AC Calibration is desired).
2. Press the range button for the range to be calibrated. The 8842A then prompts for a low reference source for that range. (See Table 6-12.) (During High-Frequency AC Calibration, the 8842A prompts only for a high reference source. In this case, proceed to step 4.)
3. Apply the requested reference source and press STORE. The display will blank briefly and then prompt for a high reference source. (See Table 6-12.)
4. Apply the requested reference source and press STORE. The display will blank briefly, and the 8842A will then begin taking readings in the selected range so that you may verify the calibration. The CAL annunciator remains on.
5. To continue, select another range. You may restart any of the calibration procedures by pressing the appropriate function button, the A/D button, or the HF AC button.

6-18. VERIFYING CALIBRATION

Table 6-12. Prompts When Calibrating Individual Ranges

PROCEDURE	FUNCTION	LOW PROMPT	HIGH PROMPT
Offset and Gain Calibration	VDC	Zero	95% of full scale ¹
	kΩ	Zero	50% of full scale
	VAC	5% of full scale ²	50% of full scale ²
High-Frequency AC Calibration	(Not applicable)	(No low prompt)	50% of full scale ³
1. Exception: The 1000V dc range has a high prompt of 1000V dc. 2. Exception: The 700V ac range has a low prompt of 100V ac and a high prompt of 500V ac. 3. Exception: The 700V ac range has a prompt of 200V ac.			

When you complete certain parts of the calibration procedure, the 8842A automatically begins taking readings so that you can verify the calibration is correct. (It is recommended that you do so.) The CAL annunciator remains lit. The 8842A continues to take readings until you select another calibration procedure or exit the calibration mode.

Specifically, the 8842A begins taking verification readings after:

1. Completing A/D Calibration.
2. Completing Offset and Gain or High-Frequency AC Calibration.
3. Completing the calibration of an individually selected range.

While the 8842A is taking verification readings, certain buttons are active or function differently:

1. If you just completed the Offset and Gain or High-Frequency AC Calibration for an entire function (not just one range), the range buttons can be used to change ranges in order to verify all ranges were calibrated correctly.
2. If you just calibrated an individually selected range, pressing another range button begins the Offset and Gain Calibration procedure for the new range.
3. You can use the RATE button to verify the calibration at other reading rates.

CAUTION

It is still possible to erase the calibration memory while the 8842A is taking verification readings.

6-19. ERASING CALIBRATION MEMORY

The 8842A allows you to erase some or all of the correction constants stored in calibration memory (U220). It is recommended that you erase the entire calibration memory before beginning calibration if the calibration memory is replaced or accidentally altered. The capability of erasing particular parts of the memory is mainly intended as a troubleshooting aid to the technician.

CAUTION

Once the calibration memory is erased, the 8842A must be recalibrated.

To erase all or part of the calibration memory, proceed as follows:

1. Press the front panel ERASE button. The display should show the erase prompt "cl" (for "clear"). If you do not press another button within 1-1/2 seconds, the 8842A returns to its previous state.
2. To complete an erasure, press one of the following buttons within 1-1/2 seconds of pressing the ERASE button:
 - a. STORE -- Erases the entire memory.
 - b. A/D -- Erases the A/D Calibration constants
 - c. Any function button -- Erases the Offset and Gain Calibration constants for all ranges of that function.
 - d. HF AC -- Erases the High-Frequency AC Calibration constants.
3. After an erasure is finished (a complete erasure takes about 3 seconds), the 8842A returns to one of the following states:
 - a. After complete erasure: Begins A/D Calibration.
 - b. After A/D erasure: Begins A/D Calibration.
 - c. After Offset and Gain erasure: Begins Offset and Gain Calibration for erased function.
 - d. After High-Frequency AC erasure: Begins High-Frequency AC Calibration.

6-20. TOLERANCE CHECK

The 8842A automatically checks that the reference input is near the value prompted. This minimizes common errors such as applying a reference source with the wrong sign. If the reference input exceeds the tolerances shown in Table 6-13, the 8842A displays ERROR 41.

If ERROR 41 occurs, the most likely cause is that the reference input is incorrect (e.g., has the wrong polarity). If the input is in fact correct, refer to the Troubleshooting heading in this section.

Table 6-13. Tolerance Limits

CALIBRATION		TOLERANCE
1.	A/D Calibration	±244 counts from prompt
2.	Offset and Gain Calibration	
	VDC, mA DC	±488 counts from prompt
	Ohms	±3002 counts from prompt
	VAC, mA AC	±3002 counts from prompt
3.	HF AC Calibration	±9999 counts from prompt

6-21. AC CALIBRATION AT OTHER FREQUENCIES

For special applications where the 8842A is to be used to measure ac voltages or currents exclusively at a single frequency or narrow range of frequencies, accuracy may be enhanced at that frequency (or range of frequencies) by performing calibration according to the following procedure. Note that this may degrade the accuracy at frequencies significantly removed from the frequency of optimization.

To optimize performance at a frequency less than 1 kHz, perform the offset and gain calibration procedure, above, using the frequency at which measurements will be made rather than 1 kHz. This technique may be used for both the VAC and mA AC functions. At the calibration frequency, the 8842A will yield accuracy closely approaching the specified mid-band performance.

To optimize performance at a frequency greater than 1 kHz, perform calibration as follows:

1. Perform the Offset and Gain Calibration procedure using inputs at 1 kHz.
2. Perform the High-Frequency AC Calibration procedure using inputs at the desired frequency of optimization rather than at 100 kHz. Skip step 5 in that procedure
3. Again perform the Offset and Gain Calibration procedure, this time using inputs at the desired frequency of optimization rather than at 1 kHz.

6-22. OPTIMIZING USE OF THE 5450A

If the Fluke 5450A Resistance Calibrator is used to calibrate the 2-wire ohms function, the following procedure is recommended to optimize the calibration of the lowest two ranges. (The 5450A has a 25 mΩ "floor" which would otherwise result in 25 digits of error in the 200Ω range of the 8842A.) In this procedure, the 8842A is referred to as the unit under test (UUT).

1. Complete Offset and Gain Calibration for the UUT's 4-wire ohms function. The UUT will then be taking verification readings.
2. Connect the UUT to the 5450A as shown in Figure 6-4.
3. Select the "SHORT" from the 5450A, and measure this value at the 5450A OUTPUT terminals using the UUT in 4-wire ohms. If in remote, take the average of four

- readings. (In remote calibration, the averaged value can be stored in the controller.) Record the value.
4. Select the "100Ω" output from the 5450A, and measure this value as in step 3.
 5. Find and record the numerical difference between the values calculated in steps 3 and 4. This value will be used as the variable input for calibrating the 200Ω range in 2-wire ohms.
 6. Repeat steps 4 and 5 using the "1 kΩ" output from the 5450A; find and record the numerical difference between this and the "SHORT" measured in step 3. This value will be used as the variable input for calibrating the 2 kΩ range in 2-wire ohms.
 7. Press the UUT's 2 WIRE kΩ button. This selects the Offset and Gain calibration procedure for the 2-wire ohms function and prompts for zero input. Select the "SHORT" from the 5450A, and calibrate all the zeros by pressing STORE.
 8. Select the "100Ω" output from the 5450A and calibrate the high point for the 200Ω range, entering the value computed in step 5 as a variable input.
 9. Select the "1 kΩ" output from the 5450A and calibrate the high point for the 2 kΩ range, entering the value computed in step 6 as a variable input.
 10. Calibrate the remaining ranges (steps D-G of Table 6-10) using the 5450A outputs.
 11. Recalibrate the low point for each 2-wire ohms range using a shorting link (Pomona MDP-S-0 or equivalent) across the UUT's HI and LO INPUT terminals.
 12. Exit the calibration mode by pressing the CAL ENABLE switch.
 13. Using the same configuration shown in Figure 6-4, verify that the UUT measures the same value (within 1 digit) in 2-wire ohms (using the offset feature to correct for 5450A floor error) as in 4-wire ohms. If the readings differ by more than 1 digit, reenable the calibration mode and repeat steps 2 through 8.

NOTE

Only 4-wire ohm calibration is allowed in the 20Ω range.

14. Cover the CAL ENABLE switch with a calibration certification sticker.

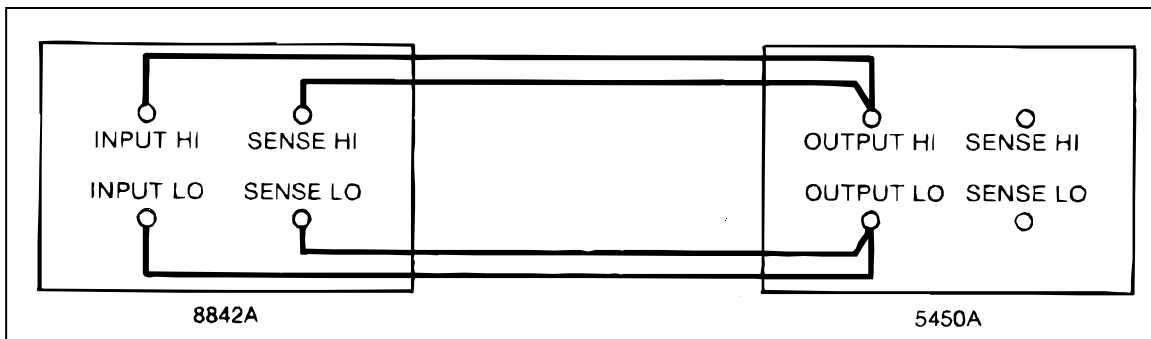

Figure 6-4. Optimizing Use of the 5450A

f6-04.wmf

6-23. Remote Calibration

If the IEEE-488 Interface is installed, the 8842A can be calibrated under remote control. Remote calibration is very similar to local (front-panel controlled) calibration. Table 6-14 shows the remote commands which correspond to the front panel features. To facilitate remote calibration, there are some differences from local calibration:

Table 6-14. Commands Used During remote Calibration

FRONT PANEL FEATURE	CORRESPONDING COMMAND	COMMENTS
Display	G2	Loads the calibration prompt into the output buffer. Not valid when the 8842A is taking verification readings.
Function Buttons	F1 through F6	In the calibration mode, these select the Offset and Gain Calibration procedure for the corresponding function.
Range	R1 through R6 and R8	In the calibration mode, these select the Offset and Gain Calibration Procedure for the corresponding range in the presently selected function. (For entering variable inputs, see VAR IN below.)
STORE	C0	Tells the 8842A that the requested calibration input is valid. This command causes the 8842A to take readings, and compute and store calibration constants. <i>NOTE</i> <i>The C0 command can take up to 22 seconds to execute. You must determine when this command is complete before sending more commands. See Timing Considerations in text.</i>
A/D	C1	Selects the A/D Calibration procedure.
HF AC	C2	Selects the High-Frequency AC Calibration procedure.
ERASE	C3	After receiving this command the display shows the erase mode prompt ('cl'). (The prompt is not loaded into the output buffer.) To complete the erasure you must then send C0. Sending any other command after the C3 command causes the 8842A to return to its previous state. There is no timeout as with the front panel ERASE button. CAUTION The command string "C3 C0" erases the entire calibration memory. A complete calibration must then be performed.
RATE	S0 through S2	Changes the reading rate while the 8842A is taking verification readings. Causes an error at any other time during calibration.
VAR IN	N<value>P2	Enters <value> as a variable input. (See Entering Variable Inputs, in text.) Causes an error if sent during A/D Calibration or when the 8842A is taking verification readings. You can check that the command was successful by checking the error status or by sending the Get Calibration Input command (G2).
--	P3<string>	Puts the <string> into calibration memory. The string must contain up to 16 ASCII characters, and be recalled with the G3 command.
NOTE: Other commands that may be used during calibration are: P1 (Put SRQ mask); the remaining Get commands; and X0 (clear Error Register).		

1. In remote calibration, you can store a 16-character message in the calibration memory which can be read by the system controller. Possible uses include storing the calibration date, instrument ID, etc.
2. Although some buttons are ignored in local calibration (e.g., the AUTO button), the corresponding remote commands (e.g., R0) load the output buffer with an error message.
3. The calibration memory is erased differently. (This is explained later.)
4. The rear panel SAMPLE COMPLETE signal acts slightly differently. During calibration, the SAMPLE COMPLETE signal is inactive. When the 8842A is taking verification readings, the SAMPLE COMPLETE signal acts the same as in normal operation.

Note that a command may be valid in some parts of the calibration procedure but not in others. The Get Input Prompt (G2) command, for instance, is not valid when the 8842A is taking verification readings. The Rate (Sn) commands, for instance, are valid when the 8842A is taking verification readings, but they are not valid at any other time during calibration. Table 6-15 shows when commands are invalid.

6-24. TIMING CONSIDERATIONS

Table 6-15. Error Numbers Which Are Displayed When Commands Are Not Valid

COMMAND	NORMAL MODE	SELFTTEST	CALIBRATION MODE			
			A/D CAL	OFFSET & GAIN CAL	HF AC CAL	VERIFICAT ION MODE
Bn		60	52	52	52	52
C0	51	60				54
C1	51	60				
C2	51	60				
C3	51	60				
Dn		60	52	52	52	52
Fn		60				
G0						
G1						
G2	51	60				54
G3		60				
G4						
G5						
G6						
G7						
N						
P0		60	52	52	52	52
P1						
P2	51	60	56			54
P3	51	60				
R0		60	52	52	52	52
R1-6		60	52	52	52	52
R7		60	52	52	52	52
R8		60	52		52	
Sn		60	52	52	52	
Tn		60	52	52	52	52
Wn						
X0						
Yn						
Z0		60	52	52	52	52
*		60	52	52	52	52
?		60				

The C0 command can take up to 22 seconds. If during this time the controller continues to send the 8842A more commands, the commands may fill up the 8842A's input buffer. If this happens, errors will probably occur.

You can avoid this problem by knowing when these commands are completed. There are three ways to determine this:

1. Monitoring the Cal Step Complete bit in the serial poll status register. This status bit is set false every time the remote processor sends a command to the in guard processor. It is then set true when the in guard processor completes the command and is ready to accept more. So you can send a command and loop on a check of the status, until the command is complete.
2. Setting the SRQ mask to generate an SRQ on Cal Step Complete. An SRQ is generated and the Cal Step Complete bit in the serial poll status response is set when a cal command is complete. This approach depends on capabilities of the controller being used.
3. Executing a delay in controller software after sending each command. (Not recommended.)

Although not usually necessary, these methods can be used for other commands as well.

6-25. REMOTE ERASURE

The C3 command allows you to erase the entire calibration memory. The erasure is executed by sending the string "C3 C0" (equivalent to pressing ERASE and then STORE). Any command other than C0 after C3 will abort the erasure. To facilitate remote calibration, the C0 command does not timeout as does the front panel ERASE button. The selective erasure that is possible from the front panel is intended as a troubleshooting aid, and is not available over the IEEE-488 Interface.

Note that the erase command can take up to 3 seconds to execute. To prevent timeout problems with the controller, you must determine when the command is completed before continuing. Several methods are presented in Timing Considerations, above.

NOTE

When erasing calibration memory, it is good practice to send the commands C3 and C0 in the same command string. Sending C3 by itself could lead to accidentally erasing calibration memory, since the C3 command does not time out as does the ERASE button.

6-26. EXAMPLE CALIBRATION PROGRAM

An example A/D calibration program is shown in Figure 6-5. The program is written in Fluke BASIC for the Fluke 1722A Instrument Controller. It uses the Fluke 5440A Direct Voltage Calibrator to perform and then verify the A/D Calibration procedure. In this program, the 8842A is at bus address 1, and the 5440A is at bus address 7.

```

This program performs the A/D Calibration procedure and then verifies the
A/D Calibration is correct. The program uses the Fluke 1722A Instrument
Controller and the Fluke 5440A Direct Voltage Calibrator. The 8842A is at
bus address 1, and the 5440A is at bus address 7.

10 DIM V(6)
20 DIM W(6)
30 DATA 0.0, 2, 0.03, 2, -0.03, 2, 0.66, 3, -0.66, 3, 1.97, 4, -1.97, 4
40 FOR A=0 TO 6 STEP 1 ! LOOP TO READ IN VERIFICATION VALUES.
50 READ V(A),W(A)
60 NEXT A
70 INIT PORT 0 ! INITIALIZE SYSTEM.

90 REMOTE @1
100 !GOTO 290 ! PROVIDES MEANS TO DO VERIFICATION ONLY.
110 PRINT "PUT 8842A IN CAL MODE, THEN HIT (RETURN)." ! INSTRUCTION NOTE.
120 INPUT Z$ ! STOP PROGRAM UNTIL (RETURN) IS HIT.
130 FOR M=1 TO 2 ! LOOP FOR NO. OF PASSES.
140 PRINT @7, "SOUT 0.0;OPER" ! SET 5440A OUTPUT TO 0.0
150 WAIT 1000
160 PRINT @1, "C1" ! PUT 8842A IN A/D CAL.
170 FOR N=0 TO 11 STEP 1 ! CALIBRATION LOOP.
180 PRINT @1, "C2"
190 INPUT @1, C ! GET 8842A CAL PROMPTS.
200 IF C > 1000 GOTO 180 ! CLEARS POSSIBLE ERROR MESSAGE IN BUFFER.
210 PRINT "PASS", "STEP", "INPUT" ! LABELS.
220 PRINT M, N, C ! DISPLAY PASS, STEP, INPUT VALUE.
230 PRINT @7, "SOUT"; C ! SET OUTPUT OF 5440A.
240 WAIT 7500 ! SETTLING TIME FOR 5440A.
250 PRINT @1, "CO " ! STORE CAL.
260 IF (SPL(1%) AND 8%) < > 8% GOTO 260 ! TEST 8840A FOR CAL STEP COMPLETE.
270 NEXT N
280 NEXT M
290 PRINT "VERIFICATION"
300 WAIT 3000
310 FOR T=0 TO 6 STEP 1 ! VERIFICATION LOOP.
320 PRINT @7, "SOUT"; V(T) ! SET 5440A OUTPUT.
330 WAIT 7500 ! SETTLING TIME FOR 5440A.
340 INPUT @1, R ! GET READING FROM 8842A.
350 R$ = NUM$(R, "S#.####") ! THIS AND NEXT 3 LINES FORMATS DISPLAY.
360 IF MID(R$, 2, 1) = "0" THEN R$ = LEFT(R$, 1) + " " + RIGHT(R$, 3)
370 IF LEFT(R$, 1) = " " THEN R$ = "+" + RIGHT(R$, 2)
380 PRINT R$, ! PRINTS DISPLAY.
390 IF ABS(R-V(T)) <= W(T)*1E-5+1E-6 THEN PRINT "PASS" ELSE PRINT "FAIL"
400 NEXT T
410 END

```

f6-05.wmf

Figure 6-5. Example A/D Calibration Program

6-27. DISASSEMBLY PROCEDURE

WARNING

TO AVOID ELECTRIC SHOCK, REMOVE THE POWER CORD AND TEST LEADS BEFORE DISASSEMBLING THE INSTRUMENT. OPENING COVERS MAY EXPOSE LIVE PARTS.

CAUTION

To avoid contaminating the printed circuit assemblies (PCAs), handle the PCAs by their edges. Do not handle the areas of the PCAs that are not solder masked unless absolutely necessary. These areas must be cleaned if contaminated.

The following paragraphs present a disassembly procedure for the 8842A. The procedure should be performed in the order presented. Remove the case first, and then remove Option -09, the True RMS AC PCA, Option -05, the IEEE-488 Interface PCA, the Main PCA, and the front panel. For reference, see the final assembly drawing in Section 7.

6-28. Case Removal

1. Remove the grounding screw from the bottom of the case. Remove two rear bezel mounting screws. (See Figure 6-6A.)
2. While holding the front panel, slide the case and rear bezel off the chassis (See Figure 6-6B). (At this point, the rear bezel is not secured to the case.)

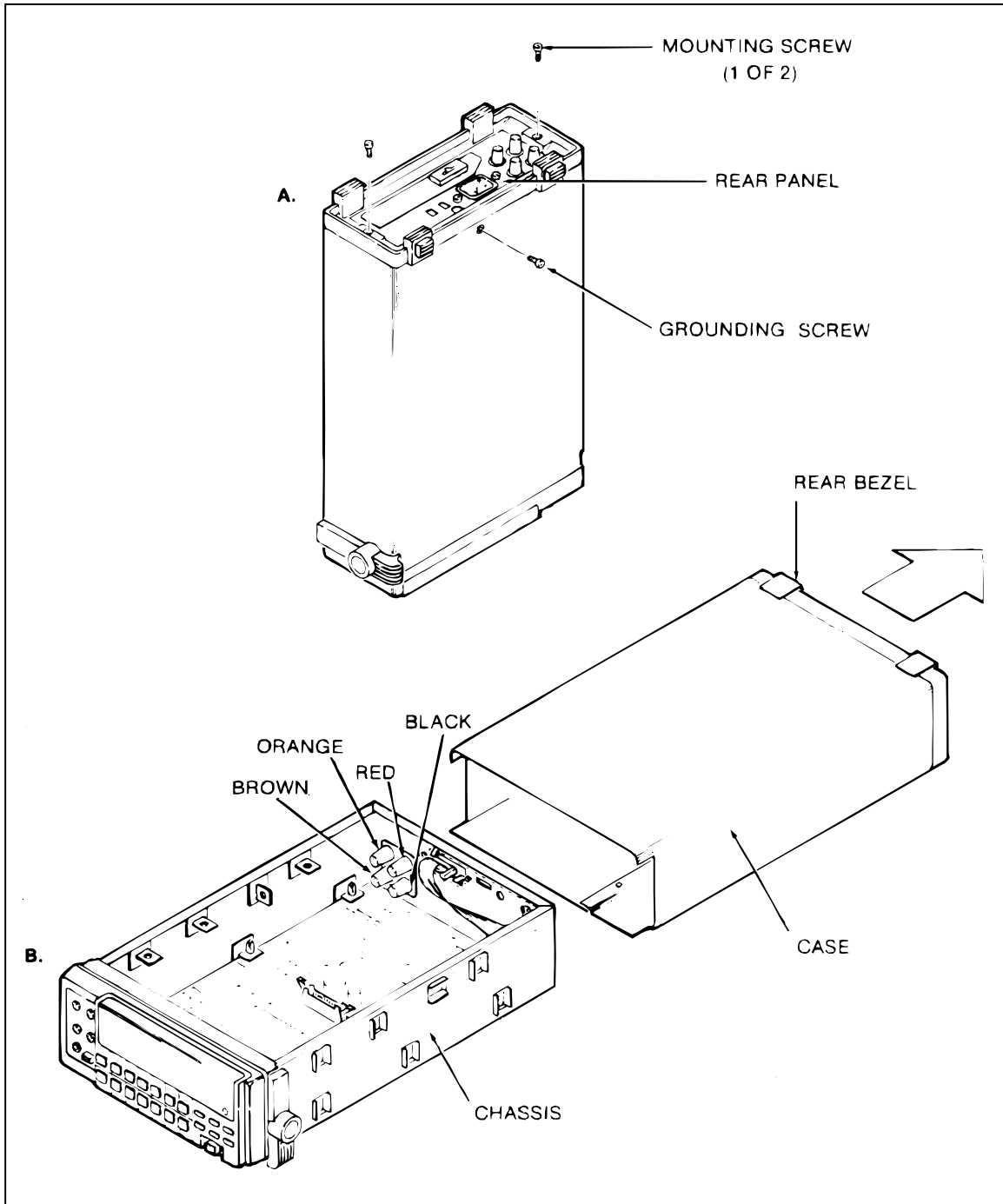

Figure 6-6. 8842A Disassembly

16-06_1.wmf

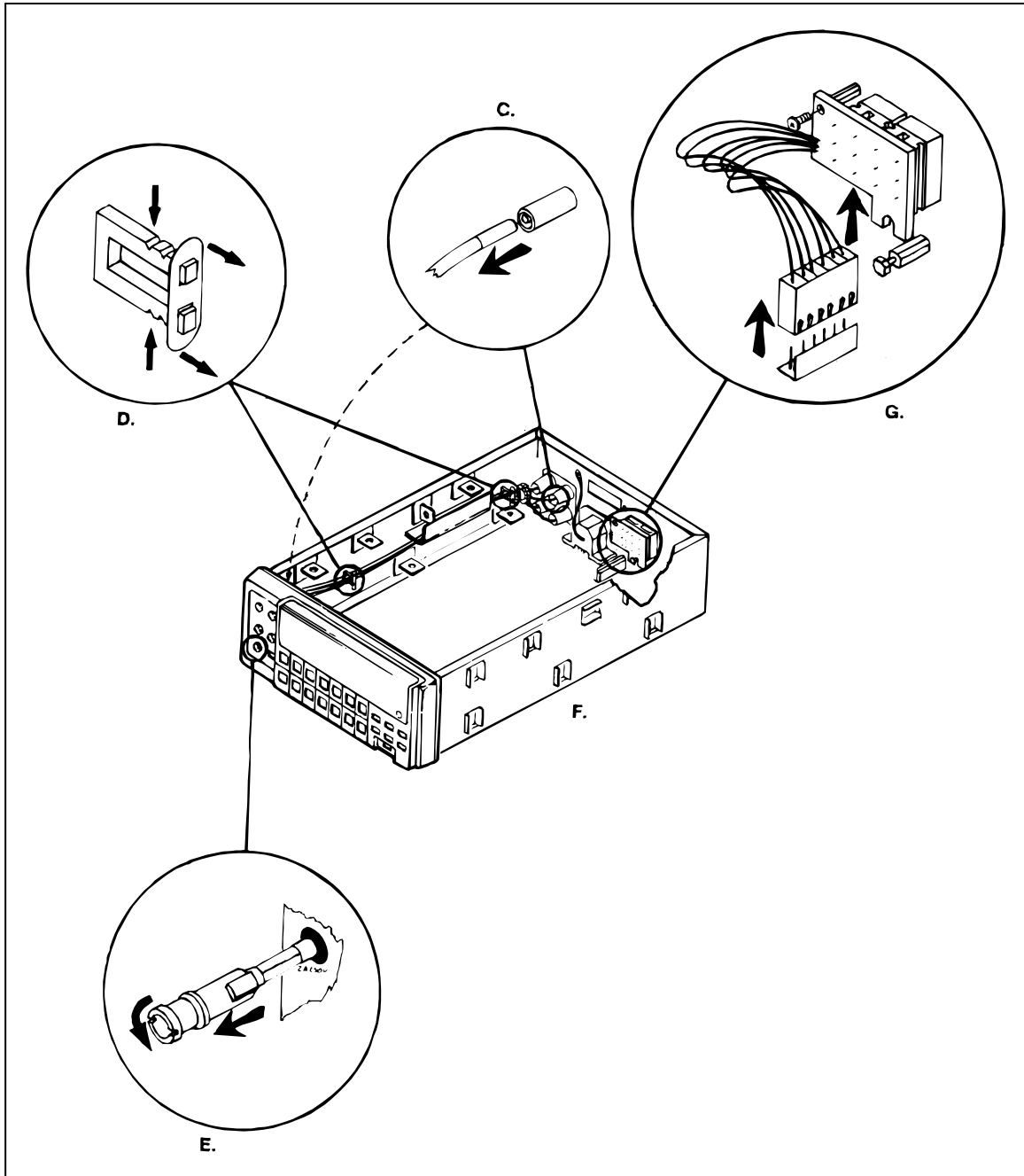

Figure 6-6. 8842A Disassembly (cont)

f6-06_2.wmf

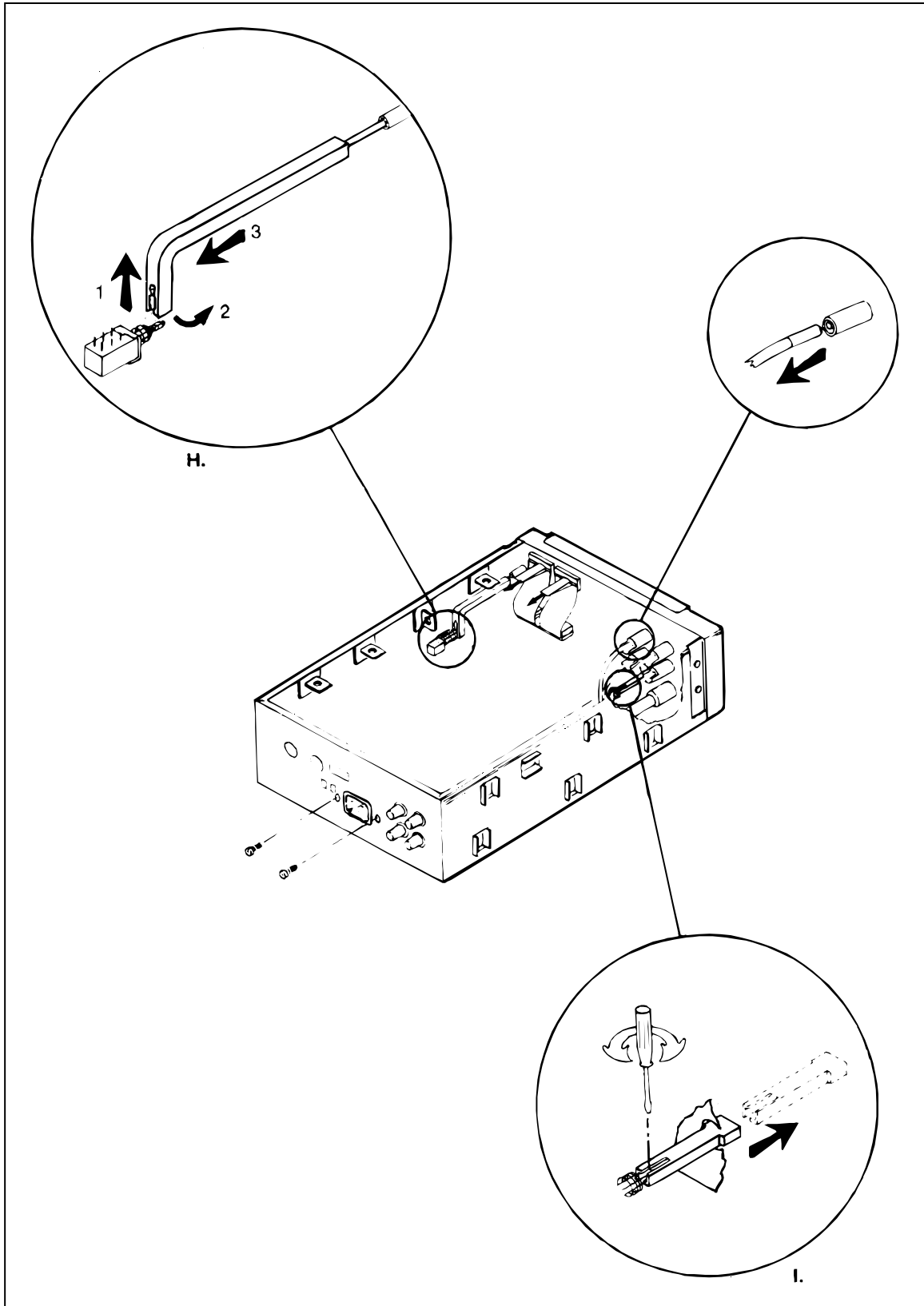

Figure 6-6. 8842A Disassembly (cont)

f6-06_3.wmf

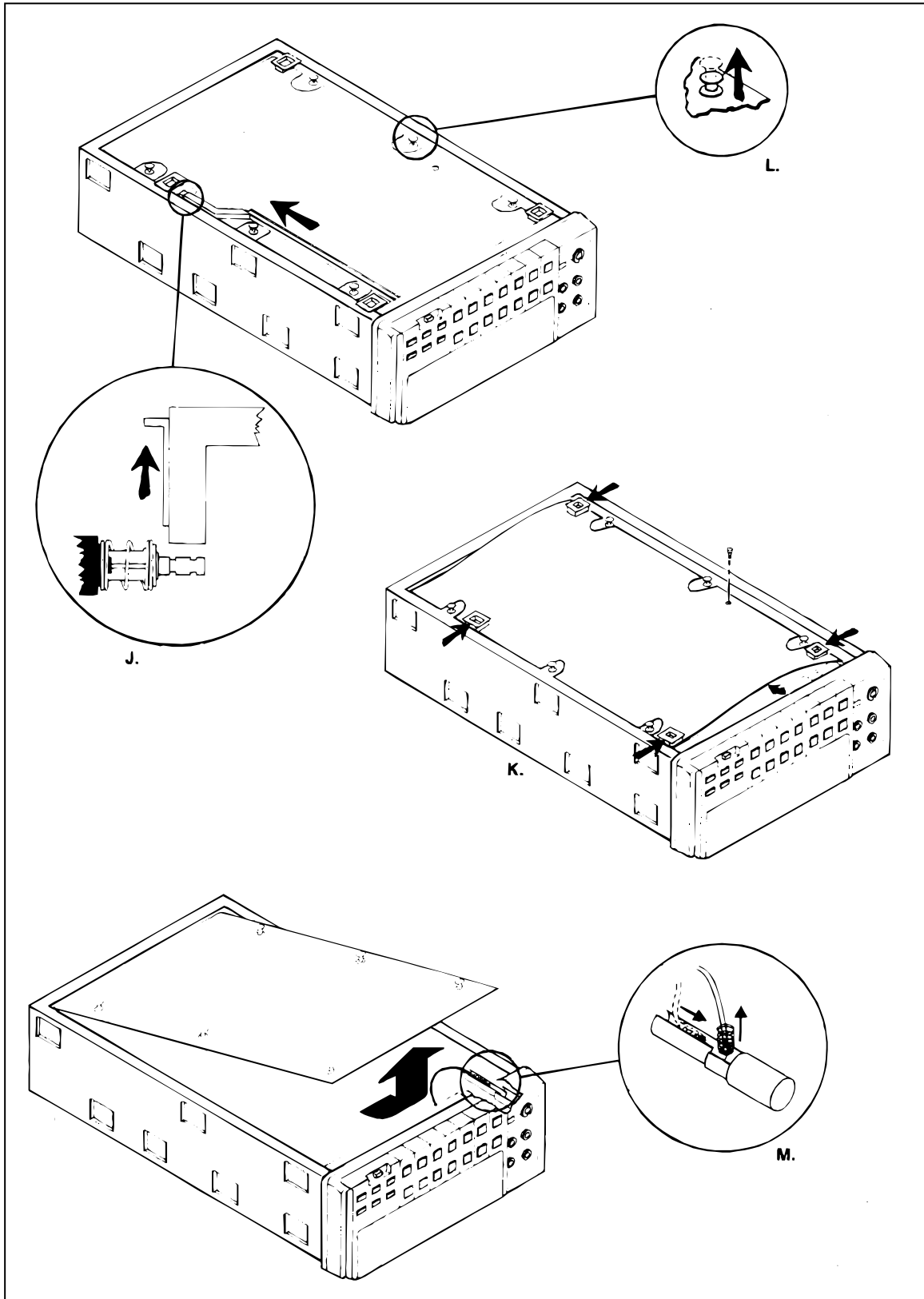

Figure 6-6. 8842A Disassembly (cont)

f6-06_4.wmf

6-29. True RMS AC PCA Removal (Option -09 Only)

The True RMS AC PCA should be removed by reversing the last three steps in Figure 809-1 (see Section 8).

1. Release the True RMS AC PCA from the chassis by pulling the four plastic latches upward (Figure 809-1E).
2. Raise the True RMS AC PCA slightly, and disconnect the red lead from the connector (J301) located on the Main PCA (Figure 809-1C).
3. Disconnect the ribbon cable from the Main PCA by releasing the ribbon connector latches (push outward; see Figure 809-1D) and pulling the ribbon cable directly outward from the connectors (Figure 809-1C).
4. Lift the True RMS AC PCA out of the chassis.

6-30. IEEE-488 Interface PCA Removal (Option -05 Only)

The IEEE-488 Interface PCA should be removed by reversing the last four steps in Figure 805-1 (see Section 8):

1. Remove the two jack screws and washers from the rear panel IEEE-488 connector (Figure 805-1H).
2. Release the IEEE-488 Interface PCA from the chassis by pulling the two plastic latches upward (Figure 805-1H).
3. Raise the forward edge of the IEEE-488 Interface PCA slightly, pull the PCA towards the front panel (guiding the IEEE-488 jack and BNC connectors out of the rear panel), and lift the PCA out of the chassis (Figure 805-1G).
4. Disconnect the ribbon cable from the IEEE-488 Interface PCA by releasing the connector latches (push outward; see Figure 805-1F) and pulling the ribbon cable out from the connector (Figure 805-1E).

6-31. Main PCA Removal

1. Disconnect the leads from the four front panel input terminals and the four rear panel input terminals by unplugging them. (Refer to Figure 6-6C.)
2. Remove the cable harness from the two cable clamps on the side of the instrument chassis. (Figure 6-6D.) Lift the cable harness clear of the sidewall cable guide.
3. Remove the front panel fuse by pressing in the lip of the 2A input terminal slightly and rotating it 1/4-turn counterclockwise (Figure 6-6E).
4. (Disregard this step if the IEEE-488 Interface was installed.) Disconnect the ribbon cable from the rear panel insert by pushing outward on the snap tab on either side of the ribbon cable connector.
5. Disconnect the two ribbon cables from the Display PCA by pulling the two plastic pull tabs directly outward from the Display PCA.
6. Remove the two mounting screws on either side of the rear panel power receptacle.
7. Disconnect the green power supply ground lead from the rear panel mounting stud. (The stud is located near the rear panel power receptacle. See Figure 6-6F.)
8. Remove the Line Voltage Selection Switch (LINE SET) PCA as follows (Figure 6-6G):
 - a. Remove the upper screw that holds the LINE SET PCA to the upper rear panel standoff.

- b. Unplug the ribbon cable from the Main PCA and lift out the LINE SET PCA.
9. Remove the push rod for the CAL ENABLE switch as follows (Figure 6-6H):
 - a. While supporting the white plunger of the CAL ENABLE switch with a finger, pop the push rod off the switch plunger by pulling the push rod directly upward.
 - b. Rotate the push rod 90 degrees toward the center of the instrument.
 - c. Pull the push rod toward the rear panel and remove it.
10. Remove the FRONT/REAR switch push rod as follows (Figure 6-6I):
 - a. Insert a blade-type screw driver in the slot visible on the top of the FRONT/REAR switch push rod at the junction of the push rod and the switch.
 - b. Twist the screwdriver slightly to release the push rod from the switch shaft, then pull the FRONT/REAR switch push rod out through the front panel.
11. Place the chassis on its side.
12. Remove the POWER switch push rod as follows (Figure 6-6J):
 - a. Insert a blade-type screwdriver in the slot visible on the top of the POWER switch push rod at the junction of the push rod and the switch.
 - b. Twist the screwdriver slightly to release the push rod from the switch shaft, then pull the rear of the POWER switch push rod out through the bottom of the chassis.
 - c. Lift the push rod out and toward the rear panel, and remove it.
13. Remove the two screws fastened to the transformer bracket, then remove the bracket.
14. Remove the Main Shield as follows (Figure 6-6K):
 - a. Remove the screw that fastens the Main Shield to the Main PCA.
 - b. Grasp the Main Shield supports on one side of the instrument and pull the supports toward the center of the chassis, bowing the Main Shield. Remove the main shield.
15. Release the six plastic latches that hold the Main PCA to the chassis by pulling the latches upward (Figure 6-6L).
16. Lift the front end of the Main PCA upward about 3 inches.
17. Free the white lead from the 2A INPUT tower as follows (Figure 6-6M):
 - a. Guide the wire, spring and fuse contact toward the front panel.
 - b. Thread the spring and fuse contact through the hole in the front end of the tower.
18. Slide the Main PCA forwards until it is free of the chassis.

6-32. Front Panel Disassembly

1. Holding the chassis vertically (with the front panel downward), remove the mounting screws from the four corners of the Display PCA (Figure 6-7A).
2. Holding the chassis vertically (now standing the instrument on the rear panel), pull the front panel off the chassis and set it aside (Figure 6-7B).
3. Remove the the display assembly (Display PCA, spacer matrix, and keypad) from the chassis as follows (see Figure 6-7C):
 - a. Release the two plastic tabs on the front of the chassis.
 - b. Let the bottom edge of the display assembly swing toward the rear of the instrument.
 - c. Pull the Display PCA toward the bottom of the chassis.
4. Separate the spacer matrix from the Display PCA by releasing the two pairs of plastic snap tabs on the back of the Display PCA (Figure 6-7D).
5. Remove the keypad from the spacer matrix.

CAUTION

The vacuum fluorescent display should not be removed from the Display PCA; these are supplied as one part.

6. Remove the display window from the front panel as follows:
 - a. Slide the window upward (away from the buttons) about 1/32 inch (Figure 6-8A).
 - b. Push the window directly outward from the front panel (Figure 6-8B).

6-33. REASSEMBLY PROCEDURE

To reassemble the instrument, proceed as follows:

1. Assemble the front panel assembly by reversing the front panel disassembly procedure (Figure 6-7). (It is easiest to lay the keypad on the Display PCA before installing the spacer matrix on the Display PCA.)

CAUTION

The four Display PCA mounting screws are self-tapping. To avoid damaging the threads, ensure the screws are threaded properly before tightening. Do not overtighten them.

2. Turn the chassis upside down.
3. Install the Main PCA through the bottom of the chassis as follows:

NOTE

When installing the Main PCA, guide the rear ribbon cable around the shield connected to the rear panel so that the cable is next to the side of the chassis. Make certain that the cable is not pinched between the shield and the Main PCA.

- a. Slide the Main PCA toward the rear panel, and position the power connector and fuse to fit through their respective openings in the rear panel.
 - b. Reinstall the white lead in the 2A INPUT tower and reinstall the 2A fuse in the front panel.
 - c. Make sure the six plastic latch heads are extended. Lower the Main PCA into position on the chassis and guide the six plastic latches into the circuit board supports on the chassis. Press the latch heads to lock the board in the chassis. Refer to Figure 6-6L. 4. Install one side of the Main Shield; bow it to install the other side, and secure it to the Main PCA with the retaining screw. 5. Place the transformer bracket back into position and fasten down with the two screws.
6. Replace the push rod for the POWER switch as follows:
 - a. Insert the button end of the push rod into the rear of the front panel.
 - b. While supporting the opposite side of the plunger with your finger, snap the other end of the push rod onto the POWER switch plunger. Refer to Figure 6-6J.
 7. Set the chassis right side up.
 8. Insert the FRONT/REAR switch push rod through the front panel and snap it into place.
 9. Reinstall the CAL ENABLE switch push rod by inserting the cylindrical end of the push rod into the rear of the front panel, then snapping it onto the CAL ENABLE switch plunger.

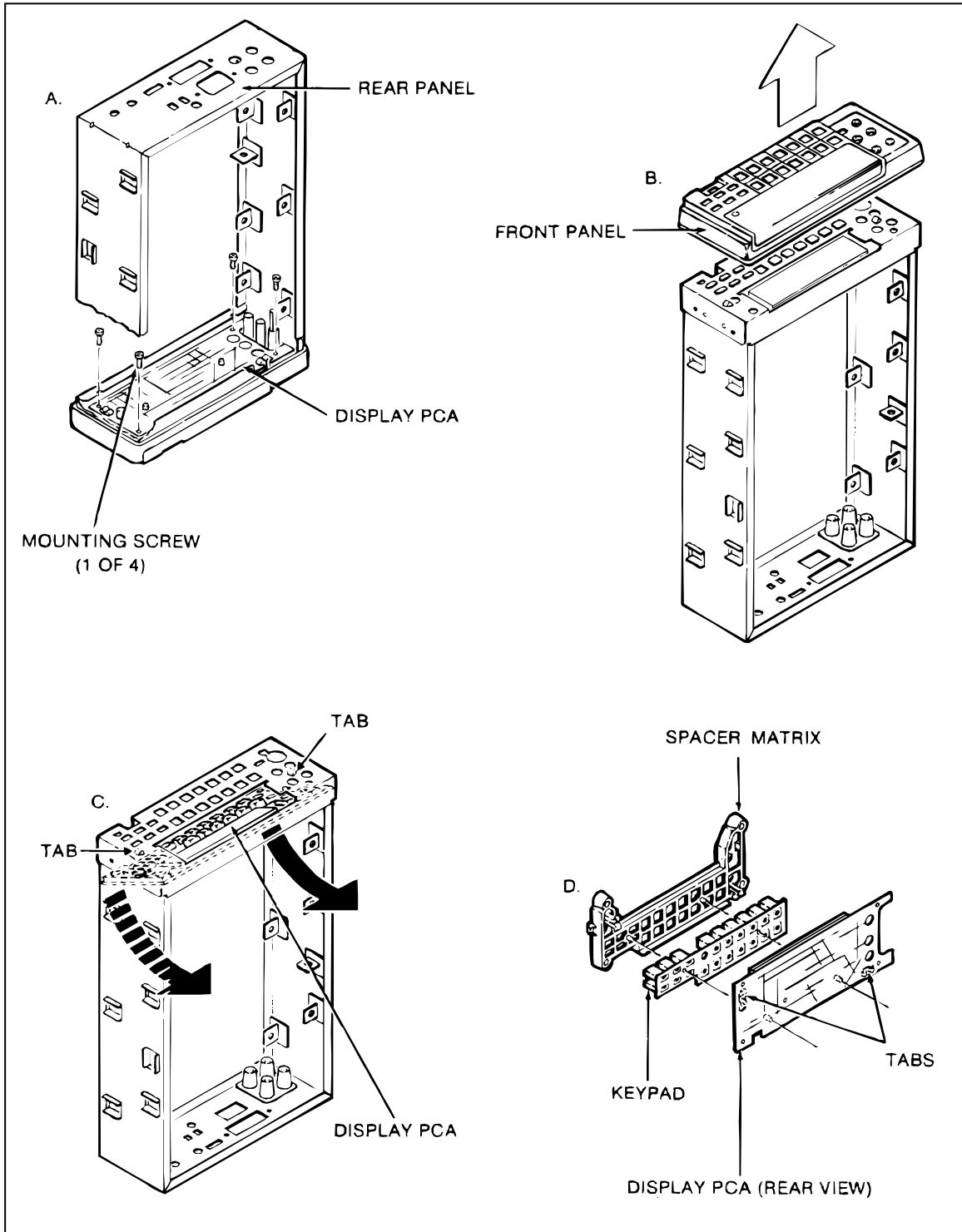

Figure 6-7. Front Panel Disassembly

f6-07.wmf

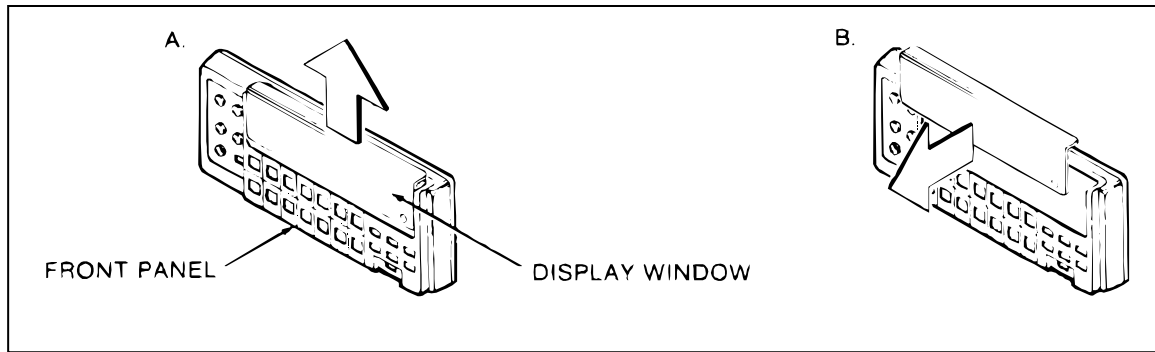

Figure 6-8. Removing the Display Window

CAUTION

Make certain that the CAL ENABLE switch shaft is in the out (disabled) position after the CAL ENABLE push rod is installed. If the 8842A is switched on with the CAL ENABLE switch in the enabled position, the 8842A may require recalibration.

10. Position the slot in the lower edge of the Line Voltage Selection Switch PCA in the slot on the lower rear panel standoff. Secure the top of the Line Voltage Selection Switch PCA to the upper standoff using the single mounting screw, and plug the ribbon cable into the Main PCA.
11. Connect the power supply ground lead to the rear panel mounting stud. (The stud is located near the rear panel power receptacle as shown in Figure 6-6F.)

WARNING

TO AVOID ELECTRIC SHOCK, ENSURE THAT THE POWER SUPPLY GROUND LEAD IS FIRMLY ATTACHED TO THE REAR PANEL MOUNTING STUD.

12. Attach the two mounting screws on either side of the rear panel power receptacle.
13. Connect the two ribbon cables to the Display PCA to the connectors. Push the cables straight in to avoid damage.
14. Reinstall the harness in the sidewall cable guide, and secure the harness to the chassis with the cable clamps.
15. Connect the leads to the four front panel input terminals according to the color codes marked on the rear side of the Display PCA.
16. Connect the leads to the four rear panel input terminals following the color codes as shown in Figure 6-6B.
17. (Option -05 only) Install the IEEE-488 Interface PCA according to the instructions in Section 8.
18. (Option -09 only) Install the True RMS AC PCA according to the instructions in Section 8.
19. Slide the case and rear bezel onto the chassis.
20. Install the two rear panel mounting screws.
21. Install the case grounding screw in the bottom of the case.

WARNING
**TO AVOID ELECTRIC SHOCK, ENSURE THAT
THE GROUNDING SCREW IS FIRMLY
ATTACHED TO THE CASE BOTTOM.**

6-34. INTERNAL FUSE REPLACEMENT

CAUTION

For fire protection, use exact fuse replacements only.

The 8842A has an internal 3A 600V slow-blow fuse (F301) in series with the 2A input terminal. To replace this fuse, remove the case according to the disassembly instructions. The fuse is held in fuse clips on the Main PCA. Do not use makeshift fuses or short-circuit the fuse holder.

6-35. EXTERNAL TRIGGER POLARITY SELECTION (Option - 05 Only)

The EXT TRIG input is factory-configured with negative polarity (trigger on falling-edge). This polarity is set by jumper E902 on the IEEE-488 Interface PCA. To select positive polarity (trigger on rising-edge), remove jumper E902 and add jumper E903.

6-36. TROUBLESHOOTING

The 8842A is designed to be easily maintained and repaired. Both the analog and digital circuits have built-in diagnostic self-tests and troubleshooting modes to facilitate troubleshooting and repair. The instrument's circuits allow troubleshooting and repair with basic electronic troubleshooting equipment such as a multimeter and oscilloscope. The troubleshooting mode in the digital controller circuitry generates special test signals to allow troubleshooting and repair without a special test signal generator or complex logic analyzer. Using the information in this section, a technician should be able to troubleshoot and repair the 8842A very efficiently. There is also a troubleshooting package available which utilizes the Fluke 9010A System Troubleshooter. The 8842A-9000 Troubleshooting Kit is described in detail in Section 8.

6-37. Initial Troubleshooting Procedure

WARNING
**TO AVOID INJURY OR EQUIPMENT DAMAGE, USE EXACT
REPLACEMENT PARTS FOR ALL PROTECTION COMPONENTS.**

When a problem occurs in the 8842A, first verify the problem is actually in the instrument. If the problem occurs when the instrument is in a system, check to see if the same problem exists when under local control. Watch the display as the instrument is turned on to see if any of the digital self-test error codes appear indicating a digital failure. If the malfunction does not involve the True RMS AC or IEEE-488 options, remove the option(s) from the instrument before proceeding.

If the display lights up, perform the self-test by pressing the SRQ button for 3 seconds. (Remember, the input terminals must be disconnected from the test leads during the self-tests. Otherwise, the 8842A may indicate errors are present.) The test numbers will appear consecutively. "ERROR" will appear on the display if a test should fail. The 8842A can be held in each of the test configurations by momentarily pressing the SRQ button. (Press any button to continue the tests.) With the description of the self-tests given below, it may be possible to isolate the failure. For reference, the states of various switches and logic lines are shown in Table 6-16 for each function, range, and reading rate.

If only one or a few failures appear in the self-tests, the problem is usually in the DC Scaling circuit. By carefully analyzing which failure(s) occurred, the fault can be located to within a few components. (Table 6-17 shows which components are exercised by each of the analog tests.) The heading DC Scaling Troubleshooting provides detailed instructions on locating and repairing DC Scaling circuit problems. However, before troubleshooting the DC Scaling circuit, all of the power supply levels should be measured to verify they are within the limits specified in Table 6-23 under Power Supply Troubleshooting, later in this section.

Table 6-16. Overall State Table

DEFINITIONS		The variables HD1, HD2, PC, TR1, & TR2 are dynamic signals generated by the A/D chip. (HD2 = TR2) These variables are true only when the corresponding dynamic signals are true. For example, the switches in line 8 are on only when HD1 is true.																											
^	logical and	A 0 stands for the switch or relay being open, and a 1 stands for it being closed. If a reference designator has a 'x' after it, the switch or relay is closed when the control voltage is low (0V). Otherwise, it is closed when the control voltage is high (5V).																											
+	logical or																												
~	logical not																												
~	asserted low signal																												
s	slow reading rate																												
m	medium																												
f	fast																												
r	range																												
GB	(Vdc^(r3+r5))+(ohms^(r5+r6))																												
GC	(Vdc^(r8+r1+r2+r4))+(ohms^(r8+r1+r2+r3+r4))																												
3PFILT (s^(Vdc+(ohms^(r1+r2+r3)))+(r8^f)																													

NORMAL OPERATING MODE																													

DC Scaling		VDC r8 r1 r2 r3 r4 r5			VAC r1 r2 r3 r4 r5				2-Wire Dhms r8 r1 r2 r3 r4 r5 r6						4-Wire Dhms r8 r1 r2 r3 r4 r5 r6				IDC r4 r5		IAC r5								
1	K301# (Vdc^(r8+r1+r2+r3))+ohms	1	1	1	0	0	0	0	0	0	0	1	1	1	1	1	1	1	1	1	1	1	1	0	0	0			
2	Q303 4ohms	0	0	0	0	0	0	0	0	0	0	0	0	0	0	0	0	1	1	1	1	1	1	0	0	0			
3	Q304 3PFILT	F	s	s	s	s	0	0	0	0	0	s	s	s	s	0	0	0	F	s	s	s	0	0	0	0	0	0	
4	Q310 4ohms	1	1	1	1	1	1	1	1	1	1	1	1	1	1	1	1	0	0	0	0	0	0	1	1	1			
5	Q311 GC	1	1	1	0	1	0	0	0	0	0	0	1	1	1	1	0	0	1	1	1	1	0	0	0	0	0		
6	U301a-1 PC^GC	1	1	1	0	1	0	0	0	0	0	0	1	1	1	1	0	0	1	1	1	1	0	0	0	0	0		
7	U301b-5 TR1^GC	1	1	1	0	1	0	0	0	0	0	0	1	1	1	1	0	0	1	1	1	1	0	0	0	0	0		
8	U301c-7 HD1^(4ohms^(r8-r4))	1	1	1	1	1	1	1	1	1	1	1	1	1	1	1	1	0	0	0	0	1	1	1	1	1			
9	U301d-9 HD1^4ohms	0	0	0	0	0	0	0	0	0	0	0	0	0	0	0	0	1	1	1	1	1	1	0	0	0			
10	U302a-1 GB^TR1	0	0	0	1	0	1	0	0	0	0	0	0	0	0	0	1	1	0	0	0	0	1	1	0	0	0		
11	U302b-5 HD2^x1	0	0	1	1	1	1	1	1	1	1	1	0	1	1	1	1	1	0	0	1	1	1	1	0	0	1		
12	U302c-7 HD1^(Vac+Iac)	0	0	0	0	0	0	1	1	1	1	1	0	0	0	0	0	0	0	0	0	0	0	0	0	0	1		
13	U302d-9 HD1^Idc	0	0	0	0	0	0	0	0	0	0	0	0	0	0	0	0	0	0	0	0	0	0	0	1	1	0		
14	U303a-1 TR2	1	1	1	1	1	1	1	1	1	1	1	1	1	1	1	1	1	1	1	1	1	1	1	1	1	1		
15	U303b-5 TR2	1	1	1	1	1	1	1	1	1	1	1	1	1	1	1	1	1	1	1	1	1	1	1	1	1	1		
16	U303c-7 HD2^x10	0	1	0	0	0	0	0	0	0	0	0	1	0	0	0	0	0	0	1	0	0	0	0	0	1	0		
17	U303d-9 HD2^x100	1	0	0	0	0	0	0	0	0	0	0	0	0	0	0	0	0	1	0	0	0	0	0	1	0	0		
34	Q317 (m^(r8+r1))+(ohms^r4^f)	0	m	0	0	0	0	m	0	0	0	0	m	0	0	0	F	0	0	0	m	0	0	F	0	0	0	0	0
Dhms Section																													
18	K401# ohms	0	0	0	0	0	0	0	0	0	0	0	1	1	1	1	1	1	1	1	1	1	1	1	0	0	0		
19	Q408 GC	1	1	1	0	1	0	1	1	1	1	1	1	1	1	1	0	0	1	1	1	1	0	0	1	1	1		
20	U402a-1 2000k+20M	0	0	0	0	0	0	0	0	0	0	0	0	0	0	0	1	1	0	0	0	0	1	1	0	0	0		
21	U402b-5 .02k+.2k+.2k+20k+200k+ohms	1	1	1	1	1	1	1	1	1	1	1	1	1	1	1	0	0	1	1	1	1	0	0	1	1	1		
22	U403a-1 20M	0	0	0	0	0	0	0	0	0	0	0	0	0	0	0	0	1	0	0	0	0	0	1	0	0	0		
23	U402d-9 20M+ohms	1	1	1	1	1	1	1	1	1	1	1	1	1	1	1	0	1	1	1	1	1	0	1	1	1			
24	U402c-7 200k+2000k	0	0	0	0	0	0	0	0	0	0	0	0	0	0	0	1	1	0	0	0	0	1	1	0	0	0	0	
25	U403b-5 20k+ohms	1	1	1	1	1	1	1	1	1	1	1	0	0	0	1	0	0	0	0	0	0	1	0	0	0	1	1	1
26	U403c-7 20M+ohms	1	1	1	1	1	1	1	1	1	1	1	1	1	1	1	1	0	1	1	1	1	1	0	1	1	1		
27	U403d-9 .02k+.2k+2k	0	0	0	0	0	0	0	0	0	0	0	1	1	0	0	0	0	0	1	1	1	0	0	0	0	0	0	0
AC Option																													
28	K801# Vac+Iac	0	0	0	0	0	0	1	1	1	1	1	0	0	0	0	0	0	0	0	0	0	0	0	0	0	1		
29	K802# (Vac^(r4+r5))+Iac	0	0	0	0	0	0	0	0	0	1	1	0	0	0	0	0	0	0	0	0	0	0	0	0	0	1		
30	U804a-1# (Vac^(r3+r5))+GC	1	1	1	1	1	1	0	0	1	0	1	1	1	1	1	1	1	1	1	1	1	1	1	1	1	0		
31	U804b-8# (Vac^r1)+Iac	0	0	0	0	0	0	1	0	0	0	0	0	0	0	0	0	0	0	0	0	0	0	0	0	0	1		
32	U804c-9# (Vac^r1)+Idc	0	0	0	0	0	0	1	0	0	0	0	0	0	0	0	0	0	0	0	0	0	0	0	1	1	0		
33	U804d-16# Vac^(r2+r4)	0	0	0	0	0	0	0	1	0	1	0	0	0	0	0	0	0	0	0	0	0	0	0	0	0	0		

Table 6-16. Overall State Table (cont)

		AUTOMATIC SELF-TEST CONDITIONS																					
		TEST #																					
		1	2	3	4	5	6	7	8	9	10	11	12	13	14	15	16	17	18	19	20	21	22
<u>front end</u>																							
1	K301* (Vdc^(r8+r1+r2+r3))+ohms	0	0	0	0	0	0	0	1	1	1	1	1	1	1	0	0	0	0	0	0	0	0
2	Q303 4ohms	0	0	0	0	0	0	0	0	0	0	0	0	0	0	0	0	0	0	0	0	0	0
3	Q304 3PFILT	0	0	0	0	1	1	1	0	0	1	0	0	0	1	1	1	1	1	1	0	0	1
4	Q310 4ohms	1	1	1	1	1	1	1	1	1	1	1	1	1	1	1	1	1	1	1	1	1	1
5	Q311 GC	0	0	0	0	1	0	0	0	0	1	1	1	1	1	0	1	1	1	1	1	1	0
6	U301a-1 PC^GC	0	0	0	0	1	0	0	0	0	1	1	1	1	1	0	1	1	1	1	1	1	0
7	U301b-5 TR1^GC	0	0	0	0	1	0	0	0	0	1	1	1	1	1	0	1	1	1	1	1	1	0
8	U301c-7 HD1^(4ohms^(r8-r4))	1	1	1	1	1	1	1	1	1	1	1	1	1	1	1	1	1	1	1	1	1	1
9	U301d-9 HD1^4ohms	0	0	0	0	0	0	0	0	0	0	0	0	0	0	0	0	0	0	0	0	0	0
10	U302a-1 GB^TR1	0	0	0	0	0	1	1	1	1	0	0	0	0	0	1	0	0	0	0	0	0	1
11	U302b-5 HD2^x1	1	1	1	0	1	1	1	1	1	0	1	1	1	0	1	1	1	1	1	1	1	0
12	U302c-7 FDI^(Vac+Iac)	1	1	1	0	0	0	0	0	0	0	0	0	0	0	0	0	0	0	0	0	0	0
13	U302d-9 FDI^Idc	0	0	0	1	0	0	0	0	0	0	0	0	0	0	0	0	0	0	0	0	0	0
14	U303a-1 TR2	1	1	1	1	1	1	1	1	1	1	1	1	1	1	1	1	1	1	1	1	1	1
15	U303b-5 TR2	1	1	1	1	1	1	1	1	1	1	1	1	1	1	1	1	1	1	1	1	1	1
16	U303c-7 HD2^x10	0	0	0	1	0	0	0	0	0	0	1	0	0	0	1	0	0	0	0	0	0	0
17	U303d-9 HD2^x100	0	0	0	0	0	0	0	0	0	0	0	0	0	0	0	0	0	0	0	0	0	1
34	Q317 1PFILT	0	0	0	0	0	0	0	0	0	0	0	0	0	0	0	0	0	0	0	0	0	0
<u>ohms section</u>																							
18	K401* ohms	0	0	0	0	0	0	1	1	1	1	1	1	1	1	1	1	1	1	0	1	0	1
19	Q408 GC	0	0	0	0	1	0	0	0	0	1	1	1	1	1	0	1	1	1	1	1	1	0
20	U402a-1 200k+20M	0	0	0	0	0	1	1	1	1	1	0	0	0	0	1	0	0	0	0	0	0	1
21	U402b-5 .02k+.2k+2k+20k+200k+ohms	1	1	1	1	1	0	0	0	0	0	1	1	1	1	0	1	1	1	1	1	1	0
22	U403a-1 20M	0	0	0	0	0	1	1	1	0	0	0	0	0	0	1	0	0	0	0	0	0	1
23	U402d-9 20M+ohms	1	1	1	1	1	0	0	0	1	1	1	1	1	1	0	1	1	1	1	1	1	0
24	U402c-7 200k+2000k	0	0	0	0	0	0	0	0	1	1	0	0	0	1	0	1	0	0	0	0	0	0
25	U403b-5 20k+ohms	1	1	1	1	1	0	0	0	0	0	0	0	1	0	0	0	1	0	0	0	0	0
26	U403c-7 20M+ohms	1	1	1	1	1	0	0	0	1	1	1	1	1	1	0	1	1	1	1	1	1	0
27	U403d-9 .02k+.2k+2k	0	0	0	0	0	0	0	0	0	0	1	1	0	0	0	0	0	1	1	1	1	0
<u>ac board</u>																							
28	K801* Vac+Iac	0	0	0	0	0	0	0	0	0	0	0	0	0	0	0	0	0	0	0	0	0	0
29	K802* (Vac^(r4+r5))+Iac	1	1	1	0	0	0	0	0	0	0	0	0	0	0	0	0	0	0	0	0	0	0
30	U804a-1* (Vac^(r3+r5))+Iac	0	1	0	1	1	1	1	1	1	1	1	1	1	1	1	1	1	1	1	1	1	1
31	U804b-8* (Vac^r1)+Iac	0	0	1	0	0	0	0	0	0	0	0	0	0	0	0	0	0	0	0	0	0	0
32	U804c-9* (Vac^r1)+Idc	0	0	0	1	0	0	0	0	0	0	0	0	0	0	0	0	0	0	0	0	0	0
33	U804d-16* Vac^(r2+r4))	1	0	0	0	0	0	0	0	0	0	0	0	0	0	0	0	0	0	0	0	0	0

t6-16_2.wmt

Table 6-17. Circuitry Tested by the Analog Self-Tests

CIRCUITRY TESTED	TEST NUMBER																					
	1	2	3	4	5	6	7	8	9	10	11	12	13	14	15	16	17	18	19	20	21	22
DC:																						
K301					•	•	•	•							•	•	•	•		•		•
Q310					•	•	•	•	•	•	•	•	•	•	•	•	•	•	•	•	•	•
Q311					•					•	•	•	•	•		•	•	•	•	•	•	•
Q304, U304																				•	•	•
R319, R315				•	•																	
U306						•	•	•	•						•							•
Z301							•	•	•						•							•
Z302							•								•	•	•	•	•	•	•	•
Z304								•	•	•	•	•	•	•								
T/H:																						
Amplifier				•	•	•	•	•	•						•	•	•	•	•	•	•	•
U301						•										•	•	•	•	•	•	•
U302	•	•	•	•			•	•	•	•					•							•
U303				•	•	•	•	•	•						•	•	•	•	•	•	•	•
Z303															•							•
OHMS:																						
Protection							•	•	•	•	•	•	•	•	•	•	•	•	•	•	•	•
U401, U404							•	•	•	•	•	•	•	•	•	•	•	•	•	•	•	•
U402							•	•	•	•	•	•	•	•	•	•	•	•	•	•	•	•
U403							•	•	•	•	•	•	•	•	•	•	•	•	•	•	•	•
Z401							•								•							•
AC:																						
U802	•	•	•																			
U803	•	•	•																			
U804	•	•	•																			
U809	•	•	•																			
A/D	•	•	•	•	•	•	•	•	•	•	•	•	•	•	•	•	•	•	•	•	•	•

t6-17.wmf

Some failures will cause many self-tests to fail. If this occurs, the fault is usually in the Track/Hold circuit, the A/D Converter, the Digital Controller circuit, or the Power Supply. Again, measure all of the power supply levels according to the limits specified in Table 6-23. The next step is to isolate the problem to a specific section.

If the self-tests display a large number of errors or if readings are noisy and/or in error, the problem is usually in the A/D Converter or Track/Hold circuit. (A large number of errors can also be caused by a problem in the Ohms Current Source.) To isolate the problem, connect a jumper between TP103 and Reference Low (TP306, or the L-shaped shield around U202). The display should typically read less than approximately 35 counts (i.e., +/-000XX where XX is less than 35) on the 2V dc range. If a good reading can be obtained (less than approximately 35 counts), the A/D Converter and Precision Voltage Reference circuits are most likely good. A more conclusive test can be made by connecting a low-impedance dc source between Reference Low and TP103 with an output voltage between -2.0V and +2.0V. The reading on the display will be of opposite polarity to the voltage applied to TP103. (Disconnecting one end of R318 will usually make it possible to display readings within 0.1% to 0.5% of the actual input.) After it has been determined that the A/D Converter or the Track/Hold circuit is not functioning properly, proceed to the corresponding heading for detailed troubleshooting instructions and guidelines.

A failure in the instrument may cause the 8842A to display random patterns or nothing at all. Usually, analog circuit failures do not cause the display to go blank or display random patterns. The best place to start troubleshooting a "dead" instrument or an instrument with a non-functional display is to check the power supply with a voltmeter for proper levels and to use an oscilloscope to check the supplies for oscillations. If all of the supplies are working correctly, check the clock for the In-Guard μC at U202-2. The signal should be an 8 MHz sine wave approximately 3.5V peak-to-peak. Then check the 1 MHz output of the A/D IC (U101) at U212-3. (If not present, check at the A/D IC at U101-14.) The signal should be a 1 MHz square wave approximately 5V peak-to-peak. The 8 MHz sine wave is generated by the clock circuit of the In-Guard μC , and the 1 MHz signal is the 8 MHz signal divided by a counter in the A/D IC. If the clock signals are correct, proceed to the heading Digital Controller Troubleshooting, below, for detailed troubleshooting instructions.

If a problem occurs in the keyboard/display area, the instrument may appear to be totally inoperative even when the measurement circuitry is still functional. The heading Digital Controller Troubleshooting provides detailed instructions on locating problems in the display/keyboard system.

Finally, as in most processor-based systems, there are communication links between the various parts of the system. Specifically, in the 8842A, there is a bus interface between analog and digital control circuits and a guard-crossing interface between logic circuits which may be separated by large potentials. Failures in these links can generate problems that may be difficult to locate and repair. However, such failures will in turn cause failures in some analog and or digital section. Thus, indirectly, troubleshooting the affected section will lead to correction of problems in the internal bus or guard-crossing circuit.

6-38. Diagnostic Self-Tests

To run the diagnostic self-tests, disconnect the test leads and press the SRQ button for 3 seconds. If the test leads are left attached to the input terminals the 8842A may indicate errors are present (most likely, errors 5, 7, 8, 9, and 10). Also, if the FRONT/REAR switch is in the REAR position, the 8842A skips tests 3 and 4, and if Option -09 is not installed, the 8842A skips tests 1, 2, and 3. For all tests, there is a 0.5 second delay period before any readings are taken. The tests are all contingent on the A/D Converter being properly calibrated, but do not depend on the Offset and Gain Calibration constants.

Failing the tests indicates that key portions of the 8842A are not performing properly. Passing the tests gives approximately a 90% probability that all VDC ranges and range r6 of 2-wire ohms can be calibrated. Passing the tests also gives a reasonable probability that it will give accurate measurements in VDC and range r6 of 2-wire ohms. However, passing the tests does not guarantee that the instrument can be calibrated in VAC, mA DC, mA AC, 4-wire ohms, or ranges r1 to r5 of 2-wire ohms.

NOTE

If the A/D Converter or Precision Voltage Reference is not working, all analog tests would show an error. If the A/D Converter is not calibrated, tests 7, 15, 19 could show an error.

If the analog self-tests indicate an error, it may be possible to isolate the problem as follows:

1. While the error code is being displayed, press the SRQ button. This latches the 8842A into the particular test configuration.
2. Referring to Table 6-18, check that the test point voltages are as shown using another DMM.

6-39. Self-Test Descriptions

Table 6-18. Self-Test Voltages

TEST NUMBER	TEST POINT	VOLTAGE
1	TP803	±5 mV dc
2	TP803	±5 mV dc
3	TP803	±5 mV dc
4	TP103	T/H output waveform for zero input (Figure 6-14)
5	TP302	±5 mV dc
6	TP302	±5 mV dc
7	TP302	+50 mV dc typical
8	TP302	+11.5V dc typical
9	TP302	+11.5V dc typical
10	TP302	+4.5V dc with possibly 1V ac (p-p) at 10 Hz
11	TP302	+4.5V dc with possibly 1V ac (p-p) at 10 Hz
12	TP302	+4.5V dc with possibly 1V ac (p-p) at 10 Hz
13	TP302	+4.5V dc with possibly 1V ac (p-p) at 10 Hz
14	TP302	+4.5V dc with possibly 1V ac (p-p) at 10 Hz
15,22	TP302	+50 mV dc typical
16	TP302	+49 mV dc typical
17	TP302	+53 mV dc typical
18	TP302	+59 mV dc typical
19	TP302	<±5 mV dc
20	TP302	+59 mV dc
21	TP302	<±5 mV dc

Note: To measure these correctly, each test must be stopped using the SRQ button. Also use TP306 (or L-shaped shield around U202) as Reference low.

- TEST 1: 200 VAC, Zero

Configures the 8842A in the 200V ac range (except that K801 is opened) and measures the open-circuit floor reading. In this range, the first and second stage buffers effectively divide any noise at the input terminals by 100. This test should be fairly immune from noise because the input terminals are always open-circuited except for capacitive feedthrough across K801.

- TEST 2: 700 VAC, Zero

Configures the 8842A in the 700V ac range and measures the open-circuit floor reading. In this range, the open-circuit reading is divided by 1000. Again, K801 is opened to reduce sensitivity to external noise.

- TEST 3: mA AC, Zero

Configures the 8842A exactly as in the mA AC function and takes a reading of the voltage across the 0.1Ω current shunt at the slow reading rate.

- TEST 4: mA DC, Zero

Configures the 8842A in the mA DC function and the slow reading rate, and measures the reading across the 0.1Ω current shunt. This test should be fairly immune to outside noise because the total driving impedance is typically less than $1\text{ k}\Omega$. The reading is not a perfect zero because of the offsets generated by charge injection of U302 and the T/H Amplifier (X10 configuration).

- TEST 5: 200 VDC, Zero

Configures the 8842A in the 200V dc range and slow reading rate. Input noise is divided by 100. Assuming no input of any kind, the T/H Amplifier is essentially shorted to ground by $100\text{ k}\Omega$ and filtered by the 3-pole analog filter. Any non-zero reading under quiet input conditions is due to the offset of the T/H Amplifier (X1 configuration).

- TEST 6: 1000 VDC, Zero

Configures the 8842A exactly as in the 1000V dc range and slow reading rate, with input noise being divided by 1000. The reading is very close to zero because of the inherent $2\text{ k}\Omega$ driving impedance to the T/H Amplifier (X1 configuration).

- TEST 7: 1000 VDC + $20\text{ M}\Omega$

Couples the 1000V dc range and $20\text{ M}\Omega$ current source together. The result is nominally 500 nA through the $10\text{ M}\Omega$ input divider. Since the 1000V dc range senses this voltage at the divide-by-1000 point of the scaling circuit, the reading should be 5 mV , or 500 counts at the A/D Converter. This test could indicate an error if input capacitance is greater than 1000 pF .

- TEST 8: 20 VDC + $20\text{ M}\Omega$

Puts the DC Scaling circuit into the 20V dc range and the Ohms Current Source into the $20\text{ M}\Omega$ range. The infinite input impedance of the 20V dc range causes the $20\text{ M}\Omega$ current source to be clamped at its maximum open circuit voltage, typically 12V . The 20V dc range scales this voltage and presents the A/D Converter with 1.15V , or 115,000 counts. This is a good test to ensure that the maximum open-circuit voltage of the Ohms Current Source is less than 13V . This test is susceptible to capacitance greater than $0.01\text{ }\mu\text{F}$ at the input terminals.

- TEST 9: 20 VDC + $2000\text{ k}\Omega$

Puts the DC Scaling circuit in the 20V dc range and the Ohms Current Source in the $2000\text{ k}\Omega$ range. The infinite input impedance of the 20V dc range causes the $2000\text{ k}\Omega$ current source to be clamped at typically 11.5V . The reading at the A/D Converter should be 1.15V . Again tests that the maximum open-circuit voltage of the Ohms Current Source is less than 13V . Capacitances greater than $0.1\text{ }\mu\text{F}$ at the input terminals can cause an error.

- TEST 10: 2 VDC + $2000\text{ k}\Omega$

Puts the DC Scaling circuit in the 2V dc range and the Ohms Current Source in the $2000\text{ k}\Omega$ range, except that its maximum open-circuit voltage is limited to less than 6.5V in this configuration. This test, as well as tests 11-13, checks clamps Q312 and Q313 and the analog filter. The reading at the A/D Converter should be an overload. Capacitances greater than $0.5\text{ }\mu\text{F}$ at the input terminals can cause an error.

- TEST 11: 200Ω , Overrange
- TEST 12: $2\text{ k}\Omega$, Overrange
- TEST 13: $20\text{ k}\Omega$, Overrange
- TEST 14: $200\text{ k}\Omega$, Overrange

These tests put the 8842A in the respective range of the 2-wire ohms function. They check that each range of the Ohms Current Source has enough compliance voltage to overload the dc front end.

- TEST 15: 1000 VDC + X10 T/H + 20 M Ω

Puts the Ohms Current Source in the 500 nA range. The resulting current through Z302 (the 10 M Ω input divider) causes a nominal divider output voltage of 50 mV. The T/H Amplifier is in X10; thus the A/D Converter sees 50 mV, or 5000 counts. This test can be susceptible to input capacitances above 1000 pF.

- TEST 16: 200 VDC + 200 k Ω
- TEST 17: 200 VDC + 20 k Ω
- TEST 18: 200 VDC + 2 k Ω

These three tests put the DC Scaling circuit in the 200V dc range and the Ohms Current Source in the respective current range. The 10M ohm input divider (Z302) senses the maximum open-circuit voltage of each range of the current source, and the T/H Amplifier (X1) presents the compliance voltage divided by 100 to the A/D Converter. Nominal readings should be 49 mV for Test 16, 53 mV for Test 17, and 59 mV for Test 18. All three tests have a pass limit of 65 mV, insuring that no more than 6.5 volts appears at the input terminals.

- TEST 19: 200 VDC, Filter On

Test 18 (above) ties the 1 mA range of the Ohms Current Source into the 200V dc range, with the three-pole analog filter on, such that the A/D reads 59 mV nominal. Test 19 decouples the DC Scaling circuit from the Ohms Current Source; the In-Guard μ C waits 28 ms and determines if the voltage at Z302-3 (the divide-by-100 point of the 10 M Ω input divider) has not discharged to zero volts, due to the long time constant of the filter.

- TEST 20: 200 VDC + 2 k Ω , Filter Off
- TEST 21: 200 VDC, Filter Off
- TEST 22: x100 T/H

The T/H Amplifier is configured in x100 mode. DC stimulus of 5 mV (similar to test 15) is amplified to 500 mV, which is applied to the A/D converter. This test can be susceptible to input capacitance above 1000 pF.

Test 20 ties the 1 mA range of the Ohms Current Source into the 200V dc range, with the 3-pole analog filter off, such that the A/D Converter reads 59 mV nominal. Test 21 then decouples the DC Scaling circuit from the ohms current source; the In-Guard μ C waits 28 ms and determines if the voltage at Z302-3 is at zero volts.

- TEST 25: In-Guard μ C Internal RAM (U202)

A GALPAT test is performed on the internal RAM of the In-Guard μ C. If there are any errors, ERROR 25 is displayed. This test is performed only upon powerup.

- TEST 26: Display RAM (U212)

A pattern is written to the Display RAM and read back for comparison. If there are any differences ERROR 26 is displayed.

- TEST 27: In-Guard μ C Program Memory (U202)

A two-byte check sum is calculated over the entire 4K Internal Program Memory and compared with the checksum bytes at the end of that memory. A special add and shift algorithm minimizes the possibility of double errors cancelling. If something is wrong with the Internal Program Memory, ERROR 27 is displayed.

- TEST 28: External Program Memory (U222)

A two-byte check sum is calculated over the entire 4K External Program Memory and compared with the checksum bytes at the end of that memory. A special add and shift algorithm minimizes the possibility of double errors cancelling. If something is wrong with the External Program Memory, ERROR 28 is displayed.

- TEST 29: Calibration Memory (U220)

Numerous single-byte checksums are placed in the Calibration Memory, one at the end of each group of calibration constants. They are calculated in such a way that the single-byte sum of all bytes in the Calibration Memory add to zero (all carries discarded) and the single-byte sums of each group also add to zero. A new checksum is calculated and written to Calibration Memory each time a full or partial calibration is performed. If the Calibration Memory is not properly configured or not working correctly, ERROR 29 is displayed. The accuracy of the 8842A is suspect.

6-40. Digital Controller Troubleshooting

The basic strategy in troubleshooting the Digital Controller circuit is to check first whether the In-Guard Microcomputer (μ C) system is functional, starting with the In-Guard μ C itself (U202). Most of this circuitry is tested using the specially provided In-Guard Troubleshooting Mode.

If the In-Guard μ C system proves to be functional, then basic instrument control is assured and troubleshooting efforts can proceed in one of two directions. If the display and keyboard appear to be malfunctioning, then they should be checked next. (See Display System, below.) If the display and keyboard are functioning correctly, you can omit Display System troubleshooting and proceed to verify that signals are arriving correctly at the inputs of the analog control devices. (See Analog Control Signals, below.) If these are also correct, the digital controller is functioning correctly, and you can proceed to the appropriate analog troubleshooting procedure.

NOTE

For the convenience of the following tests, Options -05 and -09 should be removed if present. They should only be removed in the power-off condition.

6-41. IN-GUARD MICROCOMPUTER SYSTEM

This procedure is performed entirely in the In-Guard Troubleshooting Mode. This mode is established by shorting TP205 (U202-38) to Reference Low (TP306, or the L-shaped shield around U202) prior to turning on the instrument. Refer to Figure 6-9. To maintain this mode, the short must remain in effect after the instrument is turned on. When this is done, the μ C programs U202-38 as an input (it is normally an output) to preclude any possibility of damage due to the short.

CAUTION

To avoid damaging the μ C, the short must be initiated before the instrument is turned on, not after.

The In-Guard Troubleshooting Mode also programs all the normal port outputs to display a 1 kHz square wave except that the IEEE-488 output (U202-4) sends the word "55" repeatedly at a rate of 2,000 words/second and the A/D trigger (U202-40) is a square wave at its normal frequency of 80 Hz, and DM and P23 stay high. (The data received at U202-5 is meaningless.) Adjacent port outputs display opposite phases of the 1 kHz square wave. All μ C pins that are normally only programmed as inputs are also

programmed as inputs to prevent contentions between them and the outputs from other ICs which drive them. Data coming into all μC inputs (except pin 38) is ignored.

NOTE

If the A/D IC (U101) is working properly, its watchdog timer briefly interrupts all of the In-Guard Troubleshooting Mode signals every 1.5 sec for a period of about 0.2 sec. (The signals are then re-established.) If this occurs, the main counter in U101 and its watchdog timer are operating correctly. (See step 6, below.)

When the test is complete, turn off the 8842A and remove the short from TP205.

6-42. In-Guard Microcomputer

While the 8842A is in the In-Guard Troubleshooting Mode, check the following in the order shown:

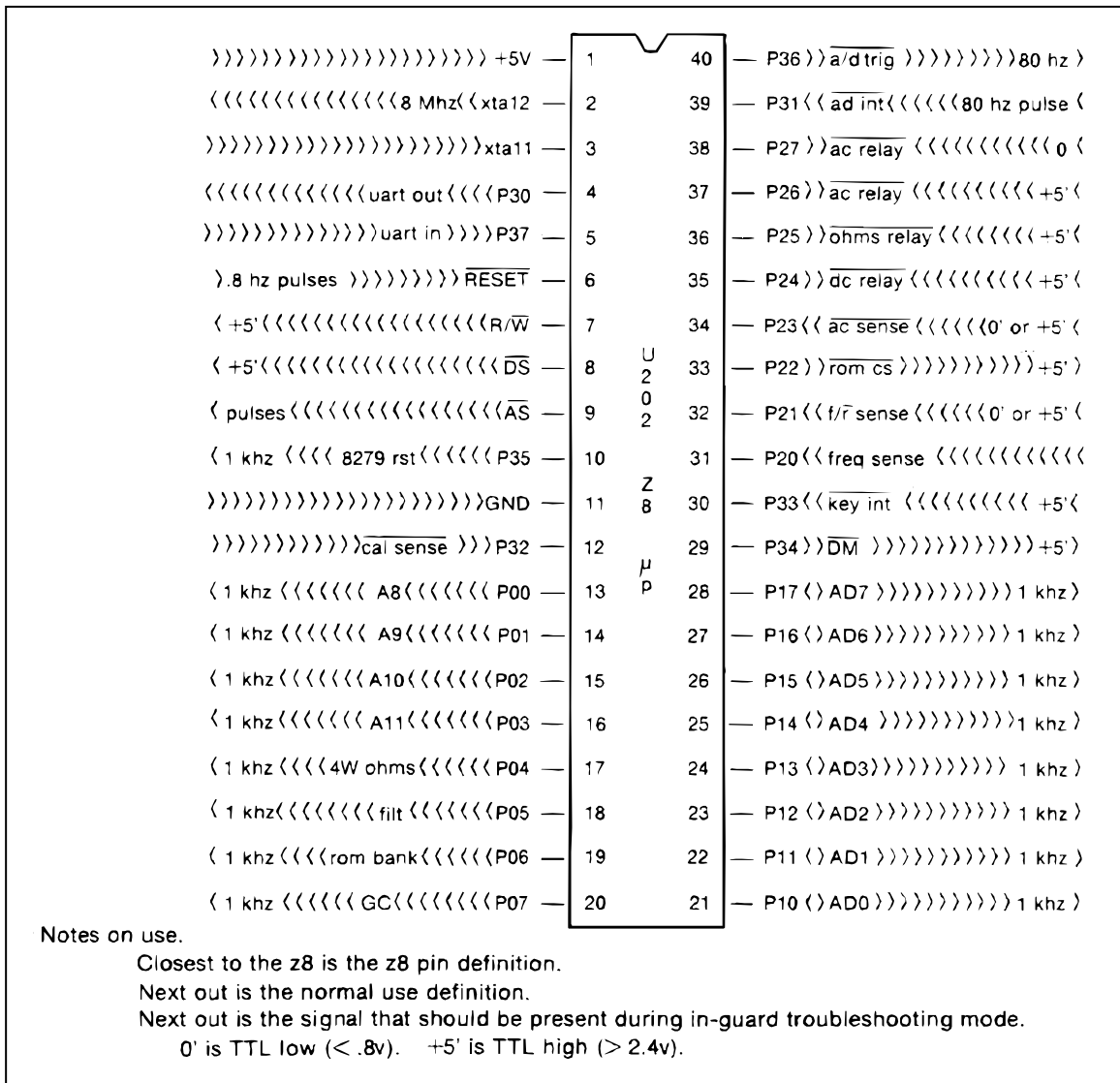

Figure 6-9. U202 Pin Diagram

f6-09.wmf

1. Power supplies: +5V dc at U202-1; 0V dc U202-11.
2. μ C clock output: 8 MHz at U202-2,-3.
3. Trigger line U202-40 (TP201): Square wave, 50% duty, low 0V, high 3.8V (nominal). The period of the trigger signal should be 12.500 ms for 60 Hz line.
4. Interrupt from A/D (U202-39): Normally low, duration 48 μ s occurs approximately 5450 μ s after falling edge of trigger signal on TP201 (U202-40).
5. Guard-crossing test pattern (U202-4): Waveform C (see Figure 6-10).
6. Interrupts from watchdog timer (U202-6): Pulsed low for 0.2 sec every 1.5 sec, exponential rise between pulses.
7. Output test patterns (see Waveforms A and B in Figure 6-10): 1 kHz square wave on indicated pins, 50% duty cycle, low 0V, high 3.8V nominal. (The waveforms are interrupted every 1.5 sec for 0.2 sec due to interrupts from the watchdog timer.) To observe these patterns, remove U220, attach a logic clip to address latch U219 and sync on U219-3 for Reference Waveform A on channel 1 of a dual trace scope. Compare channel 1 with waveforms at U202-10,-14,-16,-18,-20,-22,-24,-26,-28. These should all be the same as reference Waveform A (including phase). Then compare channel 1 with waveforms at U202-13,-15,-17,-19,-21,-23,-25,-27,-29,-33. These should be the same as Waveform B, which is simply the opposite phase of Waveform A.

6-43. Address Latch (U219)

Verify that U219-2, -6, -7, -12, -13, -16, -17 are the same as Waveform A (see Figure 6-10) on U219-3. Verify that U219-4, -5, -8, -9, -14, -15, -18, -19 are the same as Waveform B. The waveforms should be interrupted every 1.5 sec for 0.2 sec due to interrupts from the watchdog timer.

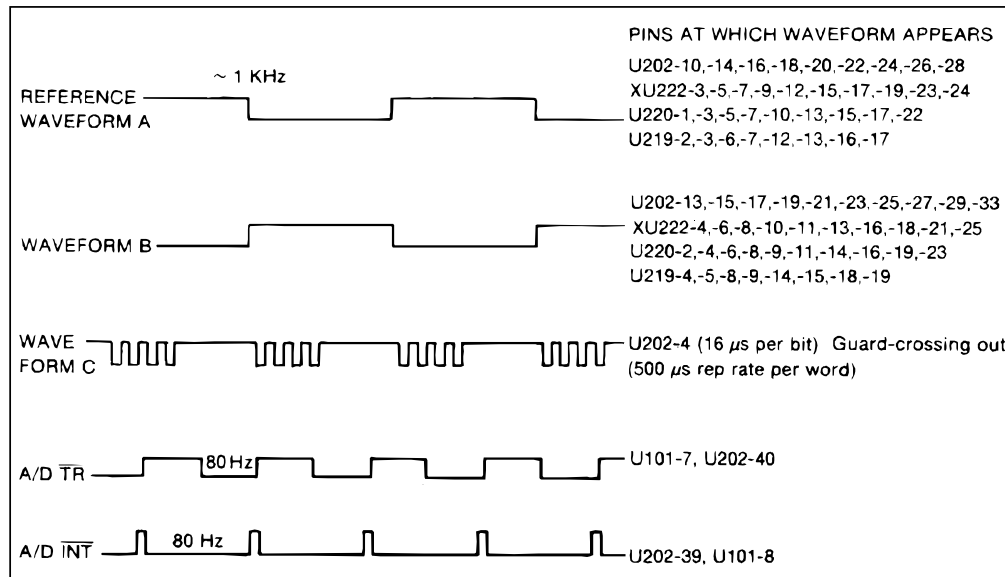

f6-10.wmf

Figure 6-10. Waveforms for In-Guard Troubleshooting Mode

6-44. External Program Memory (XU222)

Sync on U219-3. Verify that XU222-3, -5, -9, -12, -15, -17, -19, -23, -24 are the same as Waveform A (see Figure 6-10) on U219-3. Verify that XU222-4, -6, -8, -10, -11, -13, -

16, -18, -21, -25 are the same as Waveform B. The waveforms should be interrupted every 1.5 sec for 0.2 sec due to interrupts from the watchdog timer. (Note: XU222 pins refer to a 28-pin socket.)

6-45. Calibration Memory (U220)

Sync on U219-3. Verify that U220-1, -3, -5, -7, -10, -13, -15, -17, -22 are the same as Waveform A (U219-3). Verify that U220-2, -4, -6, -8, -9, -11, -14, -16, -19, -23 are the same as Waveform B. The waveforms should be interrupted every 1.5 sec for 0.2 sec due to interrupts from the watchdog timer.

6-46. Relay Buffer (U201)

At this point it is necessary to return the 8842A to the normal operating mode by turning the power switch off, removing the short from TP205 (U202-38), and installing the True RMS AC option, if present, so that U201-14, -15 may be checked. Power up the instrument. Unlike the previous checks, outputs are steady state and therefore do not require a sync signal. Logic "1" is approximately 4.3V dc.

Check that U201-14 is high (4.3V) for mA AC and all ranges of VAC, and low for all other functions.

Check that U201-15 is high (4.3V) for mA AC and 200V ac and 700V ac ranges, and low for all other functions.

Check that U201-16 is high (4.3V) for all 2-wire and 4-wire ohms ranges, and low for all other functions.

Check that U201-17 is high (4.3V) for the lowest three VDC ranges and all 2-wire and 4-wire ohms ranges, and low for all other functions.

6-47. 3-to-8 Chip Select Decoder (U208)

Make the following checks in the normal operating mode using the fast reading rate and any function and range. These sequences begin 5.5 ms after the A/D trigger, which is the falling edge at U202-40.

Check U208-13 for 0.2 μ s pulses, normally high, groups of 1, pulse spacing: 10 ms.

Check U208-12 for 0.2 μ s pulses, normally high, groups of 1, pulse spacing: 10 ms (10 μ s after pin 13).

Check U208-11 for 0.2 μ s pulses, normally high, groups of 1, pulse spacing: 10 ms (46 μ s after pin 13).

Check U208-15 for 0.2 μ s pulses, normally high, groups of 13, group width: 100 μ s, group spacing: 10 ms (230 μ s after pin 13).

Check U208-7 for 0.6 μ s pulses, normally high, groups of 5, group width: 50 μ s, group spacing: 10 ms (380 μ s after pin 13).

This concludes testing of the basic μ C system. If the keyboard or display is still suspect at this point, proceed to Display System, below. Otherwise proceed to Analog Control Signals, below.

6-48. DISPLAY SYSTEM

The display/keyboard system is operated by a complex LSI IC (U212). Generally, this IC is checked indirectly by observing behavior of the simpler logic devices which it drives.

If the keyboard is working at all, the 8842A display should be "frozen" to make the following tests. This places the 8842A in a special display test configuration. If it is not

possible to freeze the display, it should still be possible to observe the waveforms at U215, U213, U221, and U211 as described in the following paragraphs.

To freeze the display, turn off the instrument, press the POWER switch and within 1 second press the SRQ button. If all is well, all display segments will light and remain lit. Do not press any other buttons as that will release the display, allowing the instrument to resume its normal power-up sequence. This state should remain in effect for all of the following tests.

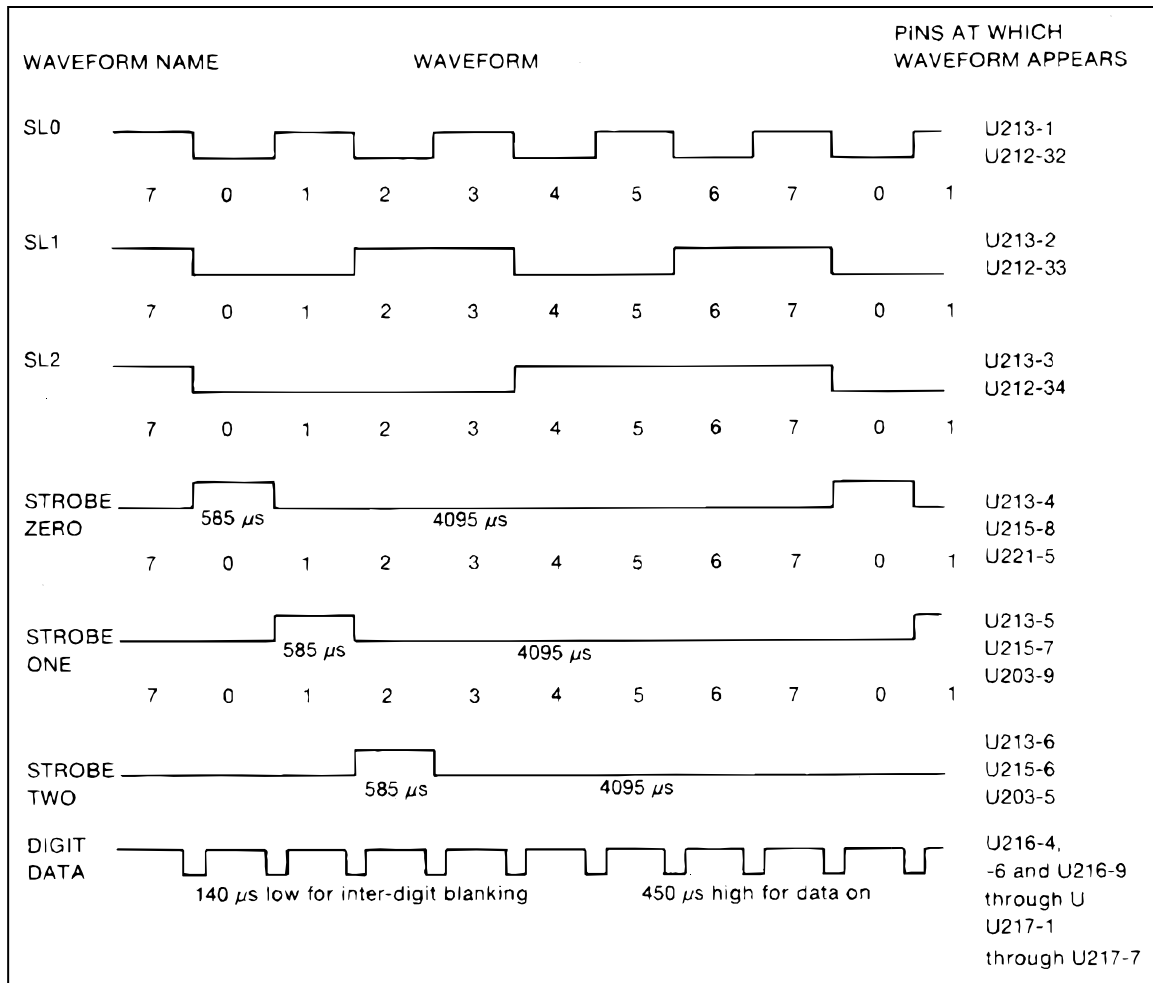

Figure 6-11. Waveforms for Display Logic

i6-11.wmf

6-49. Display Control (U212)

Check for the 1 MHz clock from the A/D IC at U212-3.

NOTE

The following waveforms are illustrated in Figure 6-11.

6-50. 8-Bit Digit Driver (U215)

Check for strobe waveforms 0-7 on U215-8, -1. Reference U215-8 for waveform STROBE ZERO. U215-7 is STROBE ONE, U215-6 is STROBE TWO etc. High level is 3.8V to 4.3V and low is near 0V.

Check for the same waveforms at outputs U215-11 through U215-18. (However, the high level should be approximately 30V.) If these waveforms are OK, then strobe decoder U213 and display control U212 are OK in this regard.

6-51. 3-to-8 Strobe Decoder (U213)

Check for strobe waveforms 0-7 on U213-4, -5, -6, -7, -9, -10, -11, -12. Reference U213-4 for STROBE ZERO. Check for strobe decoder inputs SL0, SL1, SL2 on U213-1, -2, -3 respectively.

6-52. 8-Bit Segment Driver (U217)

Check that U217-1 through U217-7 all look like the waveform DIGIT DATA. High level is 3.8V to 4.3V.

Check that U217-12 through U217-18 all look like the waveform DIGIT DATA except high level is approximately 30V.

6-53. 4-to-7 Segment Decoder (U216)

Check that U216-1, -2, -7 are low and U216-4, -6 and U216-9 through U216-15 look like the DIGIT DATA waveform.

6-54. 8-Bit Digit Driver (U218)

Check that U218-1 through U218-4 all look like the waveform DIGIT DATA. High level is 3.8V to 4.3V.

Check that U218-15 through U218-18 all look like the waveform DIGIT DATA, except that the high level should be approximately 30V.

6-55. Hex Inverter (U203)

At this point the display should be "unfrozen" by pressing any button. The instrument should then complete the power-up self-test and begin normal operation. Then do the following:

1. Check that U203-9 is the same as STROBE ONE and that U203-10 is STROBE ONE inverted.
2. Check that U203-5 is the same as STROBE TWO and that U203-6 is STROBE TWO inverted.
3. Check that U203-11 shows positive pulses 50 us to 300 us while repeatedly pushing front panel buttons in normal mode and that U203-10 shows the inverse.
4. Check that the waveform seen at U208-15 is the same at U203-13, -4 and inverted at U203-3, -12.

6-56. Hex Inverter (U221)

Check that U221-5 is the same as STROBE ZERO and that U221-6 is STROBE ZERO inverted.

6-57. Quad OR Gate (U211)

Check U211-6 for 0.2 us pulses, normally high, in two groups of 3 and 15, group widths: 50 and 100 us, group spacing: 10 ms (in fast reading rate).

Check U211-8 for 0.4 us pulses, normally high, groups of hundreds, group widths: 3.5-4 ms, group spacing: about 8 ms (variable).

6-58. Keyboard Wiring

Table 6-19 indicates which waveforms in Figure 6-11 are seen on keyboard inputs to U212 when each front panel button is pressed and held. For example, if the SRQ button is pressed and held, an inverted version of STROBE ZERO waveform is applied to U212-38. If range button "20" is pressed then inverted STROBE ONE is applied to U212-1, and so forth. Note that these waveforms are very noisy with many spikes. That is normal. Compare these waveforms with normal STROBE ZERO at U215-8.

6-59. ANALOG CONTROL SIGNALS

Table 6-19. Keyboard Wiring

SIGNAL NAME	PIN	BUTTONS THAT PRODUCE INVERTED (STROBE ZERO)	BUTTONS THAT PRODUCE INVERTED (STROBE ONE)	BUTTONS THAT PRODUCE INVERTED (STROBE TWO)
RL0	U212-38	SRQ	20Ω/mV	VDC
RL1	U212-39	LOCAL	200Ω/mV	VAC
RL2	U212-1	RATE	2	2 WIRE kΩ
RL3	U212-2	OFFSET	20	4 WIRE KΩ
RL4	U212-5	20MΩ	200	mA DC
RL5	U212-6	TRIG	2000	mA AC
RL6	U212-7	EX TRIG	Not used	AUTO

Table 6-20 is useful for determining whether the correct digital signals are being applied to the analog control devices indicated. Since most of these devices (the quad analog switches in particular) have no digital outputs, it cannot be determined directly whether the correct pattern is being latched. That determination must be made indirectly by analog means. Nevertheless, it is valuable to know whether the correct digital signals are reaching those devices.

Table 6-20. Analog Control Devices

DEVICE	REF. DES.
Relay Buffer	U201
Quad Comparator	U305
Quad Analog Switch	U301
Quad Analog Switch	U302
Quad Analog Switch	U303
Quad Analog Switch	U402
Quad Analog Switch	U403
8-Bit Latch	U803 *
Quad Analog Switch	U804 *
Quad Analog Switch	U808 *
* Option -09 only	

Correct operation of 8-bit latch U803, situated on the True RMS AC PCA (Option -09 only), can be determined directly since all of its inputs and outputs are available. Again, outputs of quad analog switches U804 and U808 are not available and must be determined by analog means.

6-60. Evaluating Static Signals

Table 6-21 may be used to determine whether or not proper signals are reaching any particular analog control device. It may also be used to quickly exercise all of the devices before beginning analog troubleshooting if it is still unclear as to which devices are suspect. A number of the inputs to these devices are static which makes them particularly easy to check.

For example, suppose quad comparator U305 appears not to be working. Connect a scope to U305-11 and step the 8842A through all functions and ranges in the following sequence:

1. VDC: 20 mV, 200 mV, 2V, 20V, 200V, 1000V
2. VAC: 200 mV, 2V, 20V, 200V, 700V
3. 2 WIRE kΩ: 200Ω, 2k, 20k, 200k, 2M, 20M
4. 4 WIRE kΩ: 20Ω, 200Ω, 2k, 20k, 200k, 2M, 20M
5. mA DC: 200 mA, 2000 mA
6. mA AC (one range only)

While doing this, observe the state of U305-11. As shown in Table 6-21, this 24-range sequence will produce the following pattern at U305-11:

111010 00000 111100 1111100 000

Table 6-21. Analog Control Logic States

DEFINITIONS												
s == logic "1" if in slow reading rate												
f == logic "1" if in fast reading rate												
f' == logic "1" if not in fast reading rate (i.e., if in slow or medium)												
UC Part	Func- tion	Pin No.	Pack	VDC	VAC	2 WIRE VOLTS	4 WIRE VOLTS	mA DC	mA AC			
				R R R R R	R R R R R	R R R R R	R R R R R	R R R R R	R R R R R			
				8 1 2 3 4 5	1 2 3 4 5	1 2 3 4 5 6	1 2 3 4 5 6	4 5	5			
BYTE #1	P07	GC	11	U305 LM339	0 0 0 0 0	0 0 0 0 0	1 1 1 1 0 0	1 1 1 1 0 0	0 0 0 0	0 0 0 0	All these signals are static	
	P06	FILT	5		0 0 0 0 0	0 0 0 0 0	0 0 0 0 0	0 0 0 0 0	0 0 0 0	0 0 0 0		
	P05		7, 8		0 0 0 0 0	0 0 0 0 0	1 1 1 1 1 1	1 1 1 1 1 1	0 0 0 0	0 0 0 0		
	P04				0 0 0 0 0	0 0 0 0 0	0 0 0 0 0	0 0 0 0 0	0 0 0 0	0 0 0 0		
BYTE #2 CS2	P27		5	U201 2585A	1 1 1 1 1 1	0 0 0 0 0	1 1 1 1 1 1	1 1 1 1 1 1	1 1 1 1	1 1 1 1	All these signals must be checked by syncing on the neg-ative-going indicated, at the state of the tar- get pin at the rising edge of the sync pulse.	
	P26		4		1 1 1 1 1 1	1 1 1 0 0	1 1 1 1 1 1	1 1 1 1 1 1	1 1 1 1	1 1 1 1		
	P25		3		0 0 0 0 0 1	1 1 1 1 1	0 0 0 0 0 0	0 0 0 0 0 0	1 1 1 1	1 1 1 1		
	P24		2		0 0 0 0 1 1	1 1 1 1 1	0 0 0 0 0 0	0 0 0 0 0 0	1 1 1 1	1 1 1 1		
BYTE #3 CS3	P07	GC	1	U301 QAS	1 1 1 0 1 0	0 0 0 0 0	1 1 1 1 0 0	1 1 1 1 0 0	0 0 0 0	0 0 0 0	All these signals must be checked by syncing on the neg-ative-going indicated, at the state of the tar- get pin at the rising edge of the sync pulse.	
	P07	CC	5		1 1 1 0 1 0	0 0 0 0 0	1 1 1 1 0 0	1 1 1 1 0 0	0 0 0 0	0 0 0 0		
	P04	4A0 (AD6)	7		0 0 0 0 0 0	1 1 1 1 1	0 0 0 0 0 0	0 0 0 0 0 0	1 1 1 1	1 1 1 1		
		(AD7) (AD3) (AD1) (AD0)	7 9 5 1		0 0 0 0 0 0	1 1 1 1 1	0 0 0 0 0 0	0 0 0 0 0 0	0 0 0 0 0 0	0 0 0 0		0 0 0 0
BYTE #4 CS4	(AD5)	(AD4)	(AD2)	5	U303 QAS	1 0 0 0 0 0	0 0 0 0 0	1 0 0 0 0 0	1 0 0 0 0 0	1 0 0 0	All these signals must be checked by syncing on the neg-ative-going indicated, at the state of the tar- get pin at the rising edge of the sync pulse.	
	(AD7)	(AD6)	(AD5)	7		0 1 0 0 0 0	0 0 0 0 0	0 1 0 0 0 0	0 1 0 0 0 0	0 1 0 0		0 1 0 0
	(AD3)	(AD2)	(AD1)	7		1 1 1 1 1 1	1 1 1 1 1	1 1 1 1 1 1	1 1 1 1 1 1	1 1 1 1		1 1 1 1
	(AD0)			9		0 0 0 0 0 0	0 0 0 0 0	0 0 0 0 0 0	0 0 0 0 0 0	0 0 0 0		0 0 0 0
BYTE #4 CS4	(AD7)	(AD6)	(AD5)	7	U402 QAS	0 0 0 0 0 0	0 0 0 0 0	0 0 0 0 0 0	0 0 0 0 0 0	0 0 0 0	All these signals must be checked by syncing on the neg-ative-going indicated, at the state of the tar- get pin at the rising edge of the sync pulse.	
	(AD3)	(AD2)	(AD1)	7		1 1 1 1 1 1	1 1 1 1 1	1 1 1 1 1 1	1 1 1 1 1 1	1 1 1 1		1 1 1 1
	(AD0)			9		0 0 0 0 0 0	0 0 0 0 0	0 0 0 0 0 0	0 0 0 0 0 0	0 0 0 0		0 0 0 0
				1		1 0 0 0 0 0	0 0 0 0 0	1 0 0 0 0 0	1 0 0 0 0 0	1 0 0 0		1 0 0 0
BYTE #4 CS4	(AD7)	(AD6)	(AD5)	7	U403 QAS	1 1 1 1 1 1	1 1 1 1 1	1 1 1 1 1 1	1 1 1 1 1 1	1 1 1 1	All these signals must be checked by syncing on the neg-ative-going indicated, at the state of the tar- get pin at the rising edge of the sync pulse.	
	(AD3)	(AD2)	(AD1)	7		0 0 0 0 0 0	0 0 0 0 0	0 0 0 0 0 0	0 0 0 0 0 0	0 0 0 0		0 0 0 0
	(AD0)			9		1 1 1 1 1 1	1 1 1 1 1	1 1 1 1 1 1	1 1 1 1 1 1	1 1 1 1		1 1 1 1
				16		0 0 0 0 0 0	0 0 0 0 0	0 0 0 0 0 0	0 0 0 0 0 0	0 0 0 0		0 0 0 0
BYTE #4 CS4	(AD7)	(AD6)	(AD5)	7	U803 LS374	1 1 1 1 1 1	1 1 1 1 1	1 1 1 1 1 1	1 1 1 1 1 1	1 1 1 1	All these signals must be checked by syncing on the neg-ative-going indicated, at the state of the tar- get pin at the rising edge of the sync pulse.	
	(AD3)	(AD2)	(AD1)	7		0 0 0 0 0 0	0 0 0 0 0	0 0 0 0 0 0	0 0 0 0 0 0	0 0 0 0		0 0 0 0
	(AD0)			9		1 1 1 1 1 1	1 1 1 1 1	1 1 1 1 1 1	1 1 1 1 1 1	1 1 1 1		1 1 1 1
				12		0 0 0 0 0 0	0 0 0 0 0	0 0 0 0 0 0	0 0 0 0 0 0	0 0 0 0		0 0 0 0

t6-21.wmf

Next move to U305-5 and repeat. The slow reading rate gives the following pattern at U305-5:

111111 00000 111000 1111000 000

If the instrument is not in the slow reading rate, it gives the following pattern at U305-5:

000000 00000 000000 0000000 000

Next move to U305-7 and repeat. The pattern at U305-7 will be:

000000 00000 000000 1111111 000

6-61. Evaluating Dynamic Signals

The procedure for evaluating the dynamic signals is only slightly more involved. For example, consider U302-7 in Table 6-21. At the right end of that row the table says to sync on U302-3. The sync pulse is negative-going. Apply it to channel 1 of a dual-trace scope syncing on the leading (negative-going) edge. Observe the target pin (U302-7) on channel 2 of the scope. While stepping through the 24 ranges observe the state of the target pin exactly when the sync pulse goes from low to high. (See Figure 6-12.) (This procedure works best in the fast reading rate since the repetition rate of the sync pulse on U302-3 is greater.) Using this procedure, the following pattern should be seen:

00000 11111 000000 000000 0 1

Note that the last eight rows in Table 6-21 are actually outputs of U803. Therefore, observing those pins proves not only that the control signals are correct but also that U803 itself is functioning correctly.

6-62. DC Scaling Troubleshooting

Whenever there is a failure in the DC Scaling circuit, first check the power supply voltages for all active components. (Supply voltages and pin numbers are listed in Table 6-22.) A test of the bootstrap supplies for U306 is described later under this heading.

After checking the power supplies, use an oscilloscope to check the digital logic input pins of quad analog switches U301, U302 and U303. These should show digital signals with high =>+3V and low =<+0.5V.

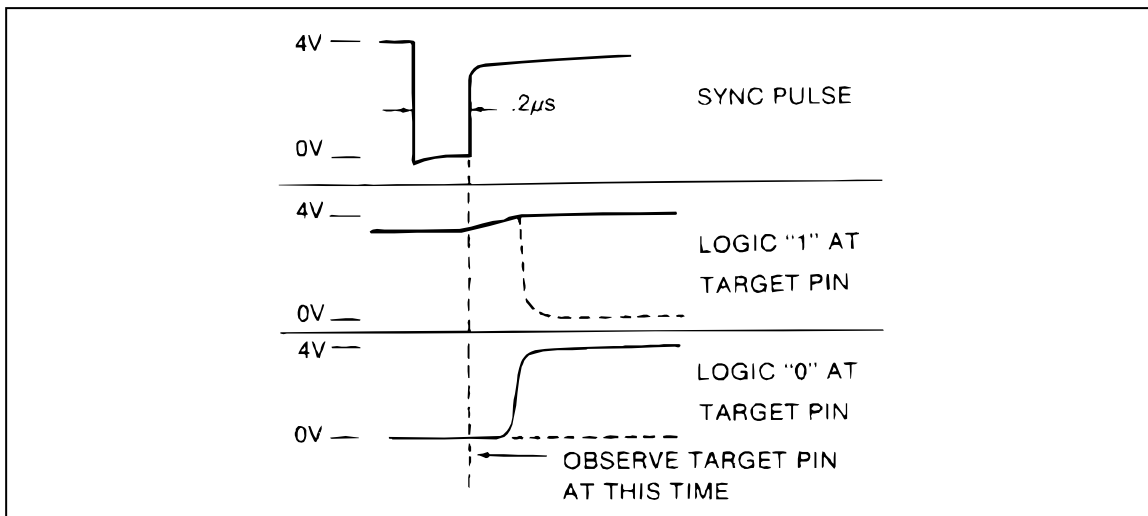

Figure 6-12. Typical Dynamic Control Signals

f6-12.wmf

Table 6-22. DC Scaling and Track/Hold Supply Voltages

PIN OR DEVICE	SUPPLY VOLTAGE	PIN OR DEVICE	SUPPLY VOLTAGE
U301-6	+5V	U303-20	+7.5V
U301-10	0V	U303-11	-8.2V
U301-20	+7.5V	U304-4	-8.2V
U301-11	-5V	U304-7	+7.5V
U302-6	+5V	U305-3	+5V
U302-10	0V	U305-12	-5.5V(Nom)*
U302-20	+7.5V	U307-4	-15V
U302-11	-5V	U307-7	+15V
U303-6	+5V	Q305,c	+30V
U303-10	0V	Q306,c	-30V
*With 0V input.			

In the 20V range, any voltage applied to the HI INPUT terminal (relative to Reference Low) should be present at U306-3. If it isn't, trace the voltage from the HI INPUT terminal to U306-3 to isolate the problem.

To check U306, select the VDC function and the 2V range. Measure the voltage at TP302 while applying first 1V and then 0V (a short) across the HI and LO INPUT terminals. If 1V and then 0V appear at TP302, U306 is probably OK. If not, the problem is in U306 or its bootstrap supplies (TP301 and TP303).

To check the bootstrap supplies, put the 8842A in the 20V range and measure the voltage at TP301, TP302, and TP303. TP301 should be 6.3V (nominal) above TP302, and TP303 should be 6.2V (nominal) below TP302. If the bootstrap supplies are operating correctly, measure the voltage at U306-3 and U306-6 for input voltages of +20V and -20V; if the voltage at U306-3 differs from U306-6, then U306 is bad.

To check the dc input path after U306, short the HI and LO INPUT terminals and read the display. If zero is displayed for ranges r3 and r5 but not for r1, r2, and r4, then the signal path including Q311 and U301B is suspect. To check Q311, apply a 1V dc input in the 2V range and check that the voltage at the drain and source of Q311 is 1V. If not, Q311 or its driver is bad. If 1V appears at U301-16, but not at the display, then U301 may be bad.

If zero is not displayed for r3 and r5 with the HI and LO INPUT terminals shorted, then Z301 or U302D is probably bad.

6-63. Track/Hold Troubleshooting

If a problem is suspected in the Track/Hold (T/H) circuit, first check the power supply voltages of all active components. (See Table 6-22.)

Next, check the T/H output waveform at TP103 with an oscilloscope. Set the 8842A to the VDC function and 2V dc range, apply +1V dc across the HI and LO INPUT terminals, and trigger the scope from the falling edge of line not-TR (TP201). The waveform should look like that in Figure 6-13. The circuit may be checked as follows:

1. Short the HI and LO INPUT terminals, and select the 2V dc range.
2. Short U301-14 to ground (Reference Low). The 8842A should read within 10 counts of zero. (The actual value is not as important as its stability.)
3. Connect U307-6 to U303-18, and monitor the voltage at TP103 using another multimeter. The 8842A should read about the same as the external multimeter, but with opposite sign.

If the 8842A fails step 2 but not step 3, then U303 is bad. If the 8842A fails both steps 2 and 3, then the fault is in the A/D Converter or the T/H Amplifier. To tell which, lift the end of R318 closest to the front panel (connected to U307-6) and apply an input of less than +2V to TP103. If the A/D Converter is OK, the 8842A will display the applied voltage with the opposite polarity. (For example, if you apply +1V, it should display -1V.) The readings may differ by a slight offset.

6-64. Ohms Current Source Troubleshooting

Malfunctions in the ohms functions can be caused by a fault in the Precision Voltage Reference, Ohms Current Source, or Ohms Protection. Malfunctions can also be caused by a fault in the DC Scaling circuit which loads the Ohms Current Source.

First check the power-supply levels (see schematic). Then check all digital logic input pins of the quad analog switches (U402 and U403). These should show digital signals with high =>+3V and low =<+0.5V.

To determine whether the Ohms Current Source is being loaded down by the DC Scaling circuit, select the VDC function and connect a 10 k Ω resistor between the collector of Q404 and ground (Reference Low). (Selecting the VDC function opens K401, and configures the Ohms Current Source in the 20 k Ω range.) If the voltage across the 10 k Ω resistor is 1V, then the Ohms Current Source is working (at least in the 20 k Ω range), and the problem is probably due to a defect in the DC Scaling circuit.

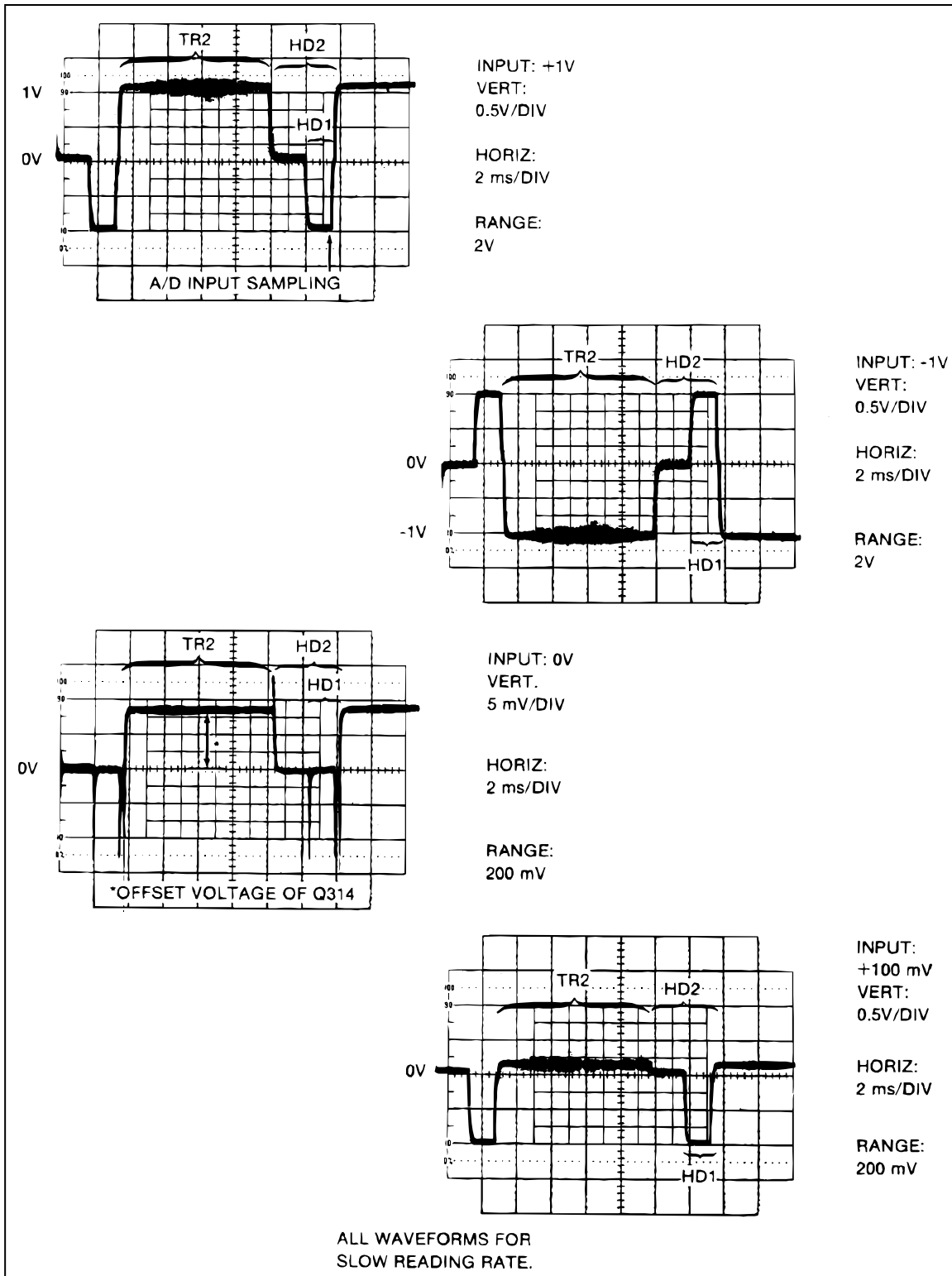

f6-13.wmf

Figure 6-13. Typical Output Waveforms for Track/Hold Circuit (TP103)

To test whether the Ohms Current Source is actually being sourced out the HI and LO OUTPUT terminals, select the 20 k Ω range and the 2-wire ohms function, connect a 10 k Ω resistor across the HI and LO INPUT terminals, and measure the voltage across this resistor with another voltmeter. There should be a 1V drop across the resistor.

If the ohms functions do not work in any range, check the supplies at U401 (+/-15V), U404 (+30V and -5V), U402 (+15V, +5V, and 0V), and U403 (+15V, +5V, and 0V), and check the -7V reference at R416. Also, test the Ohms Protection circuitry as follows: Select the 20 k Ω range and 2-wire ohms function, connect a 10 k Ω resistor to the HI and LO INPUT terminals, and bypass the protection circuitry by connecting the emitter of Q402 to the junction of R410 and R309. If a reading of 10 k Ω is displayed, the protection circuitry is defective. To isolate the problem, successively short each part of the protection circuitry that is in series with the Ohms Current Source, until the display reads 10 k Ω .

If the ohms functions work in only certain ranges, suspect resistor network Z401 or analog switches U402 or U403. To test the analog switches, select a defective range and connect a short across the switches that are supposed to be closed in that range. If the Ohms Current Source then works, one of the analog switches is probably bad. If the range still doesn't work, then Z401 is probably bad.

To test the first stage of the Ohms Current Source, short U402-19 to Reference Low through a 2 k Ω resistor and check that the voltage across R401 is 7.0V (nominal) and that the voltage at U401-6 is -4V (nominal). If the voltages are correct, the first stage of the Ohms Current Source (U401 and Q401) is working. If not, suspect U401 or Q401. (Under no circumstances should U401-6 ever be positive.)

If the first stage of the Ohms Current Source is working, test the second stage as follows:

1. Select the 20 k Ω range and apply a 10 k Ω input.
2. Check that the voltage between TP403 and U402-16 is +5V.
3. Measure the voltage at U404-6 with respect to ground. If the voltage at U404-6 is negative, U404 is bad. (Under no condition should U404-6 ever be negative.)

6-65. Precision Voltage Reference Troubleshooting

If there is a failure of the Precision Voltage Reference, check the power supply levels at U702. U702 requires two supplies, +15V and -15V, which must be within approximately +/-5% of their nominal value. Using an oscilloscope, check that the power supplies and op amp outputs (U702-1 and U702-7) are free from ripple and oscillations.

If the supplies are correct, check the output voltage levels at TP701 and TP702. The voltages should be +7.00000V +/-1000 ppm and -7.00000V +/-250 ppm. Also check that the reference amplifier output voltage (U702-1) is nominally +6.5V.

If the outputs are grossly out of tolerance (e.g., stuck at +15V or -15V), the most likely cause is a bad op amp (U702) or open resistor network (Z701 or Z702). If the outputs are slightly out of tolerance, the most likely cause is a defective or out-of-tolerance resistor in Z701 or Z702. Because Z701 is precisely matched with U701, Z701 and U701 must be replaced as a matched set.

Shorts between lands or runs can also cause small errors (10 ppm to several hundred ppm). Shorts between sense and output lands can cause small errors that are not related to resistor networks. Load regulation problems can also be caused by shorts between sense and load lines.

In some rare cases, the op amps (U702A and U702B) could be out of spec, causing a small error. The maximum input offset voltage of the op amps used in the circuit is 3 mV.

6-66. A/D Converter Troubleshooting

If there is a failure of the A/D Converter, all power supply levels should be checked at the op amps (U102 and U103) and the A/D IC (U101). The A/D Converter has a total of seven supplies: +15V, -15V, +5V, +7.5V, -8.2V, +7.00000V, and -7.00000V. All supplies should be within 5% of their nominal values except for the +7.00000V and -7.00000V reference supplies, which should be within +/-1000 ppm and +/-250 ppm respectively. The bootstrap supplies (lines BS1 and BS2) should be +7V and -7V (+/-10%) referenced to the + input of the A/D amplifier (U103-3).

Troubleshooting the bootstrap supplies can often be made easier by putting the 8842A in EX TRIG (to stop the A/D Converter) and connecting the input of the A/D Converter (TP103) to INPUT LO (Reference Low on the schematic). The bootstrap supplies are then referenced to instrument common (Reference Low).

NOTE

For the following tests, set the 8842A to the VDC function and the 2V range, and trigger the oscilloscope from the falling edge of line not-TR (TP201).

If all supplies are correct, the next most useful troubleshooting tool is the A/D output waveform at TP101, which can be checked with an oscilloscope. The waveform should look like the one shown in Figure 6-14 when the input voltage is at 50% of the selected range. Various portions of the waveform correspond to different parts of the A/D cycle. By examining the waveform, problems in the A/D Converter can be isolated down to one or two components.

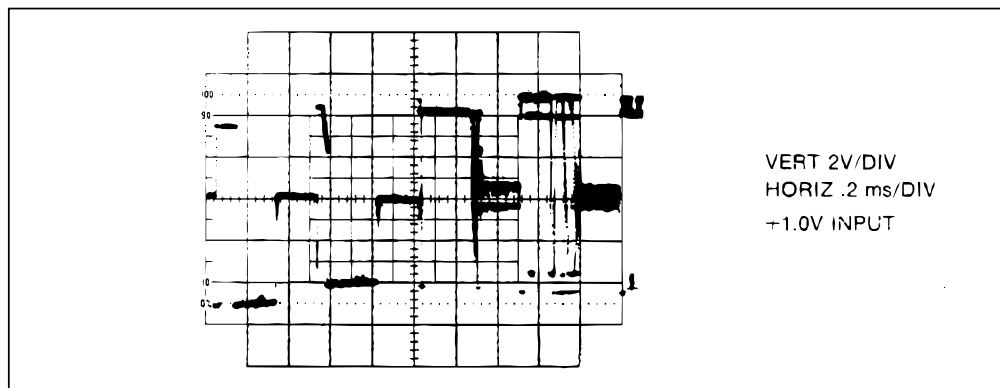

Figure 6-14. Output of A/D Amplifier (TP101)

f6-14.wmf

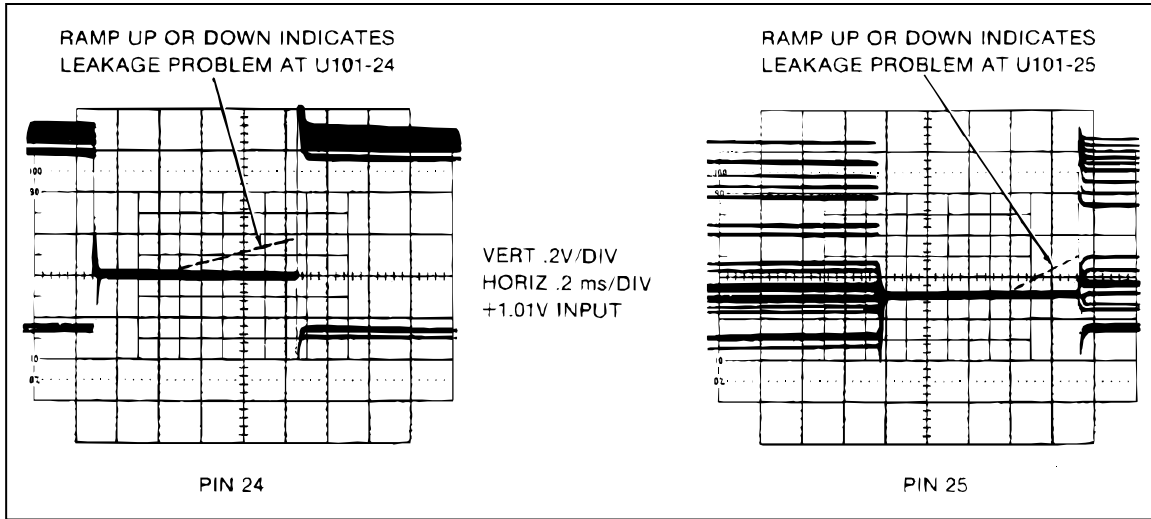

Figure 6-15. Waveforms at U101-24 and U101-25

f6-15.wmf

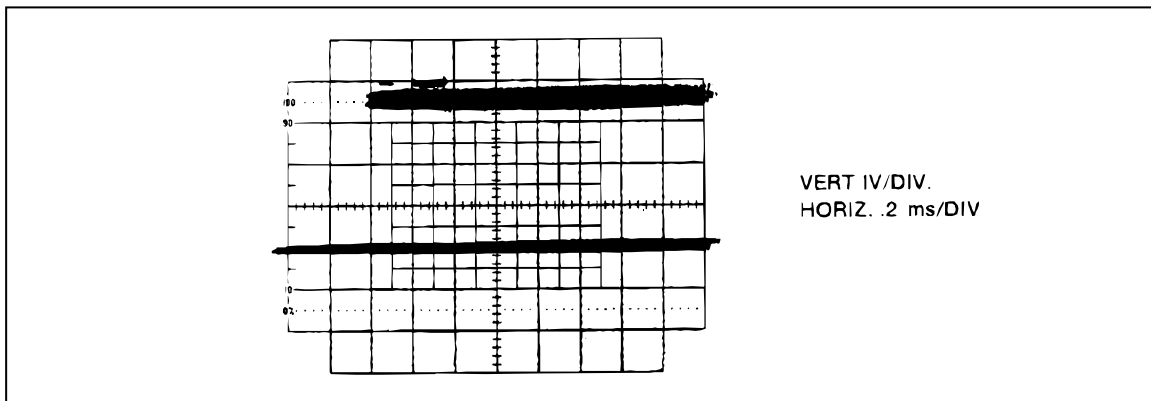

Figure 6-16. Typical Bus Data Line Waveform

f6-16.wmf

The waveform at the storage capacitors can often be used to locate leakage problems. The leakage can be due to contamination on the Main PCA or to defective switches in U101. Figure 6-15 shows the waveforms across storage capacitors C102 and C103 (U101-24 and U101-25, respectively) for a specific input.

The A/D Converter communicates with the In-Guard μ C via the internal bus, which also goes to several other sections of the instrument. What looks like a problem in the A/D Converter may actually be caused by a problem in another section of the instrument which is loading down the bus data lines (U101-1, -2, -3, -38, -39, -40). A typical waveform at one of the data lines is shown in Figure 6-16. One of the data lines can be loaded down so that the In-Guard μ C fails to recognize data sent over that line. If so, the amplitude of the signal of the bad line would be less than 3V peak-to-peak.

One technique of finding an overloaded or shorted data line is to remove the In-Guard μ C and drive one data line at a time through a 1 k Ω resistor. Measure the voltage drop across a length of the line. Normally the voltage drop across the line is zero volts (less than 5 μ V). Voltage drops larger than 5 μ V indicate a short. (The voltage drop is caused by excessive current flowing through the line.)

When troubleshooting the A/D Converter it may be desirable to determine what the reading is at the A/D Converter when the display is definitely incorrect. A digital

problem between the A/D Converter and the In-Guard μ C can cause erroneous or noisy readings or offsets. Similar problems may be caused by a failure of the Calibration Memory (U220) or by bad A/D calibration constants. (To check for bad A/D calibration constants, clear the calibration memory.)

Readings at the A/D Converter can be determined by interpreting the waveform at the DAC output (TP102). Waveforms at TP102 for several input levels are shown in Figure 6-18. The A/D reading can be calculated by knowing the weight of each bit and by weighting each nibble correctly. (The first nibble is weighted 1, the second $1/16$, the third $1/16^2$, the fourth $1/16^3$, etc.) Figure 6-18 shows how to read the A/D output for an input of 0.66V by interpreting the waveform at TP102 using the first three nibbles.

Troubleshooting the A/D Converter for defective components can be simplified by setting the circuit in a quiescent state. This can be done by selecting EX TRIG, which causes all A/D activity to stop. The A/D Converter is then in the autozero configuration, and the offset of the amplifiers and the various levels in the bootstrap circuits can be easily measured with a voltmeter. Oscillations at the outputs of the amplifiers and other abnormal signals can easily be identified with an oscilloscope.

6-67. Power Supply Troubleshooting

If the display does not light up, first check the following:

1. Is the instrument plugged in to an energized outlet providing alternating current at a frequency of 47 Hz to 440 Hz and a voltage within +/-10% of that selected by the rear panel line voltage selection switches?
2. Is the POWER switch ON (pushed in)?
3. Is the rear panel fuse blown?

CAUTION

For fire protection, use exact fuse replacement only.

If the rear panel fuse is blown, replace it with a 250V fuse of the proper rating for the line voltage selected. Use 1/4A slow-blow for 100V and 120V power-line voltage and 1/8A slow-blow for 200V and 240V power-line voltage. If the fuse keeps blowing, measure the resistances of the power transformer (T601) windings. They should be within 10% of the values shown on the schematic. If not, the transformer is probably shorted. Also inspect the area around the transformer POWER switch and power-cord connector to make sure there isn't something shorting out the traces. If the IEEE-488 Interface board is suspected of causing the problem, it can easily be unplugged. Check the crowbar circuit (CR615 and Q601, and R605). If CR615 or Q601 is shorted or if there is a large amount of leakage or R605 is open, fuses may continue to blow.

If everything looks OK but the fuse keeps blowing, troubleshooting may be performed by powering the instrument through a variac, applying only enough line voltage to find the problem without blowing the fuse. NEVER USE A LARGER FUSE. To do so will only turn a small problem into a big one.

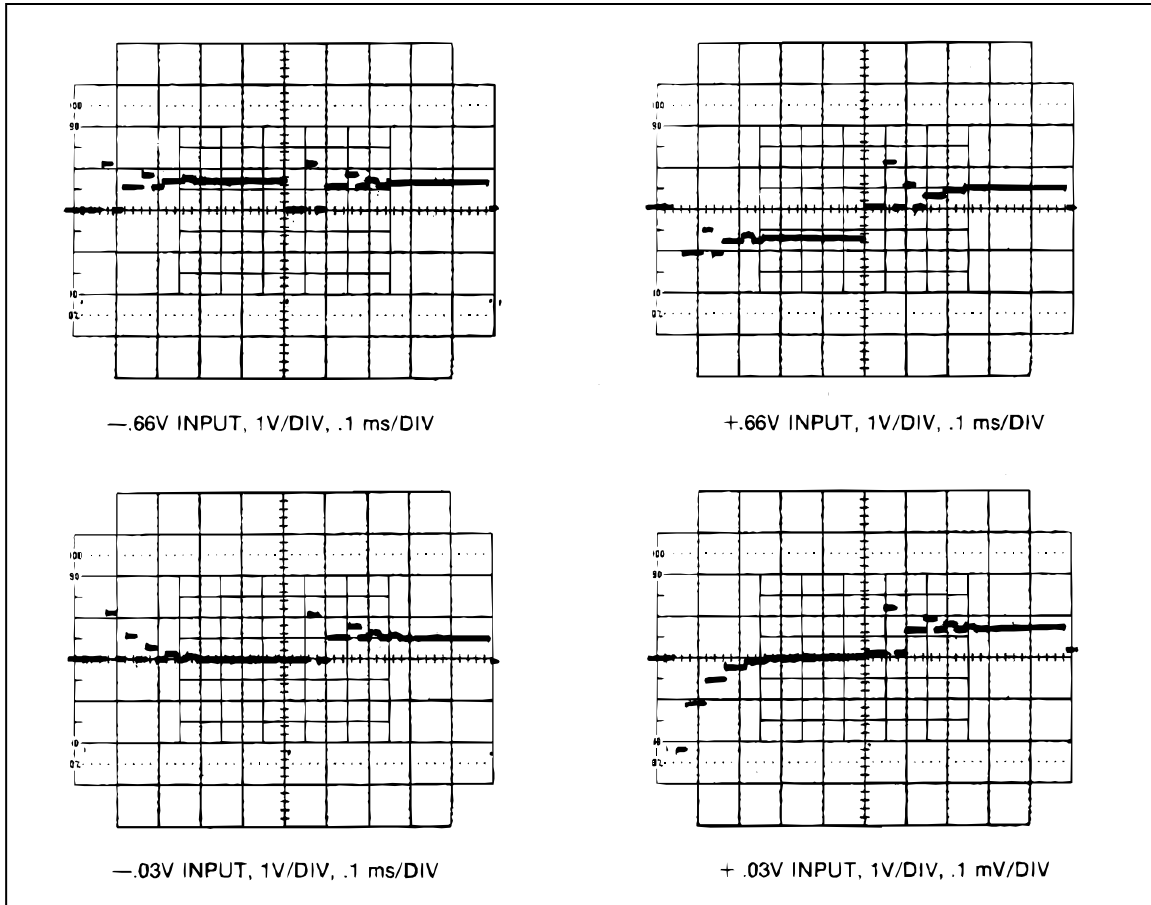

Figure 6-17. Waveforms at TP102 for Several Inputs on 2V DV Range

f6-17.wmf

Since power supply problems can produce symptoms in many different sections of the instrument, the first step in troubleshooting any problem should usually be a quick check of the power supplies. For each power supply (TP801-TP806), check the level with a voltmeter and check for ripple with an ac-coupled oscilloscope. The dc voltages should be within the limits given in Table 6-23.

If a supply is too high, either its three-terminal regulator has failed or a fault elsewhere in the instrument has shorted two supplies together. After repairing such a problem, make certain that nothing else was damaged by the overvoltage.

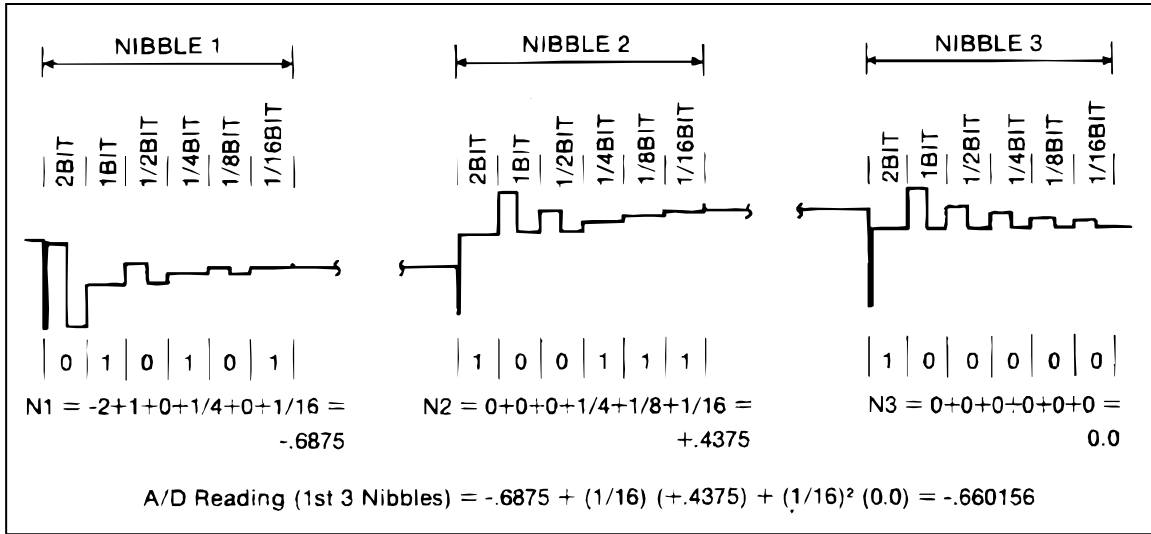

Figure 6-18. Calculating the A/D Reading From TP102 Waveform

f6-18.wmf

Table 6-23. Power Supply Voltages

TEST POINT	LIMITS (in volts)	
	MINIMUM	MAXIMUM
+5V	4.75	5.25
+7.5V	7.00	7.87
+15V	14.25	15.75
+30V	28.45	31.55
-8.2	-8.61	-7.60
-15V	-15.75	-14.25
-30V	-31.55	-28.45

If a supply is too low, there are a number of possible causes. First check the input to the affected regulator. If it is not at least 1V above the maximum output given in Table 6-23, the cause may be a bad transformer winding (check the resistance), open or shorted rectifiers, a shorted filter capacitor, or a shorted regulator. The latter two failures will usually blow the line fuse.

All regulators incorporate current-limiting which allows them to shut down in the event of a load failure. Therefore if the power supply output is too low, the first step should be to determine if it is due to a high load caused by a failure elsewhere in the instrument. Frequently the faulty component can be found by using a multimeter with at least 5 digits resolution to check the supply pins of all components powered from that supply. Connect one lead of the voltmeter to the appropriate test point for the power supply under test and use the other lead to probe the loads. Small voltage drops across the PCA traces can be detected in this way, and the fault isolated. If any component other than one of the regulators is too hot to touch, there is something wrong with it or with something connected to it.

The True RMS AC PCA, if installed, uses +5V and +/-15V. If there is a problem with one of those supplies, first disconnect the True RMS AC PCA. If the problem goes away, troubleshoot the True RMS AC PCA using the procedure given later in this section.

With most power supply problems, the output voltage is too low or too high. More subtle problems that may be encountered include high ripple or oscillation. If more than 10 mV of line-frequency ripple exists on one of the power supply outputs, it is usually caused by the input being too low, causing the regulator to drop out of regulation. It is also possible (but not likely) that the regulator itself is defective. High-frequency oscillation (frequently synchronized with the 1 Mhz or 8 Mhz clock) is usually the result of a bad regulator or output bypass capacitor. A fair amount of high-frequency noise is generally present on all the supplies, particularly +5V, and should not cause any concern unless the instrument behaves erratically or the reading is noisy.

6-68. IEEE-488 Interface Troubleshooting (Option -05)

6-69. SERVICE POSITION

To provide easy access to the IEEE-488 Interface PCA and the Main PCA, the IEEE-488 Interface PCA can be placed in the specially provided service position as follows:

1. Remove the case from the chassis according to the Case Disassembly procedure provided earlier in this section.
2. Release the two nylon latches that hold the IEEE-488 Interface PCA in place by pulling the latches upward.
3. Position the IEEE-488 Interface PCA vertically as shown in Figure 6-19 and latch it in place by pressing the two nylon latches into the mounting supports specially provided on the chassis.

6-70. DIAGNOSTIC PROGRAM

To facilitate troubleshooting, the IEEE-488 Interface provides a diagnostic program which places the instrument in known configurations. To initiate the diagnostic program, proceed as follows:

CAUTION

To avoid damage to the 8842A or other equipment, the 8842A must be disconnected from all other IEEE-488 Interface instruments while the diagnostic program is running.

1. Ensure the 8842A POWER switch is OFF.
2. Disconnect all cables from the rear panel IEEE-488 connector.
3. Short TP903 to TP905.
4. Power up the 8842A. The 8842A should display ERROR 50. To exit the troubleshooting mode, open the jumper and cycle the POWER switch from off to on.

Once the diagnostic program is started, rear-panel IEEE-488 address switches A3, A2, and A1 can be used to select one of four diagnostic modes, as shown in Table 6-24. In this table, Configuration indicates which Out-Guard μ C I/O port bits are programmed as outputs and driven with a signal, as shown in Table 6-25.

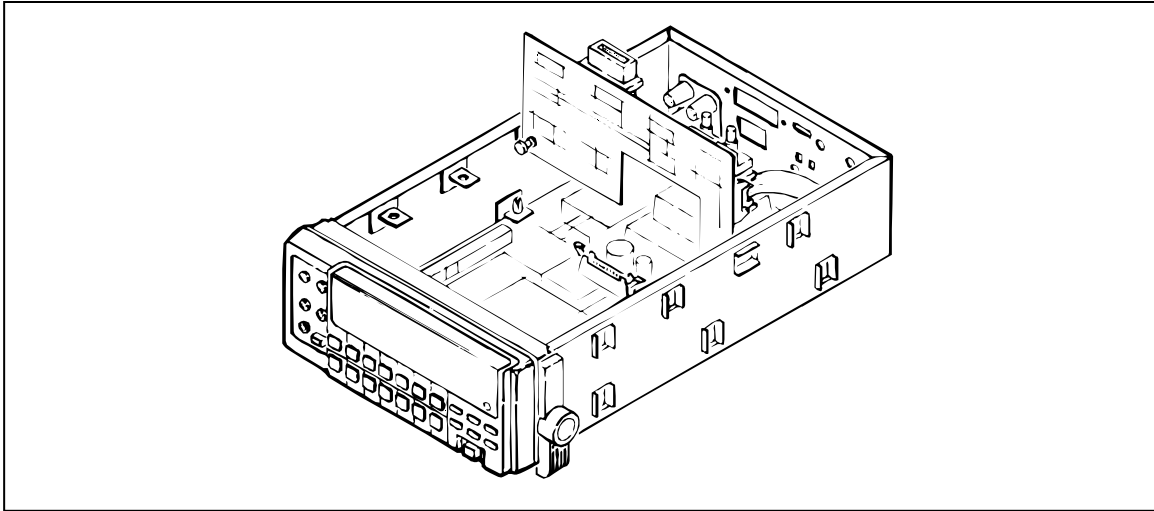

f6-19.wmf

Figure 6-19. Option -05 Service Position

Table 6-24. Diagnostic Modes

SWITCHES			CONFIGURATION
A3	A2	A1	
1	0	1	Static, odd-port bits = 1, even-port bits = 0
1	1	1	Static, odd-port bits = , even-port bits = 1
1	X	0	Dynamic
0	X	x	Read/Write

NOTES:

- “x” means switch setting does not matter.
- “Static” means the Out-Guard μ C I/O port bits programmed as outputs are driven to a constant logic 1 or 0 level (as determined by switch A2).
- “Dynamic” means the Out-Guard μ C I/O port bits programmed as outputs are driven with a 610 Hz, 50% duty cycle square wave. All odd port bit numbers are 180 degrees out of phase with even port bit numbers.
- “Read/Write” means that data is read from and written to the NEC7210 IEEE chip (U901) when DS (U901-8) is low. R/W (U901-7) determines whether the data is being read from or written to the NEC7120. The address bits are always 3 (0011) and the data bits are incremented each time.

Table 6-25. I/O Port Configurations

PORT BIT	CONFIGURATION		PORT BIT	CONFIGURATION	
	Static Dynamic	Read/Write		Static Dynamic	Read/Write
PO-0	OUT	Address	P1-0	OUT	Data
PO-1	OUT	Address	P1-1	OUT	Data
PO-2	OUT	Address	P1-2	OUT	Data
PO-3	OUT	Address	P1-3	OUT	Data
PO-4	IN	IN	P1-4	OUT	Data
PO-5	IN	IN	P1-5	OUT	Data
PO-6	IN	IN	P1-6	OUT	Data
PO-7	IN	IN	P1-7	OUT	Data
P2-0	IN	IN	P3-0	IN	IN
P2-1	IN	IN	P3-1	IN	IN
P2-2	IN	IN	P3-2	IN	IN
P2-3	IN	IN	P3-3	IN	IN
P2-4	IN	IN	P3-4	IN	IN
P2-5	IN	IN	P3-5	IN	IN
P2-6	IN	IN	P3-6	Clock	Clock
P2-7	IN	IN	P3-7	serial	Serial

NOTES:

- Due to external hardware conflicts, the following bits are NEVER driven by the Out-Guard μ C in ANY diagnostic mode: P0-4,5,6,7; P2 (all bits); P3-1,2,3,4.
- P3-6 is the 4 MHz clock for the NEC7210 IEEE chip (U901).
- P3-7 is programmed as the serial output, and constantly transmits hex 55 every 820 μ s at 62,000 baud in all four diagnostic modes. This causes the front panel error message.

6-71. True RMS AC Troubleshooting (Option -09)

6-72. SERVICE POSITION

To provide easy access to the True RMS AC PCA and the Main PCA, the True RMS AC PCA can be placed in the specially provided service position as follows:

1. Remove the case from the chassis using the Case Disassembly procedure provided earlier in this section.
2. Release the four nylon latches that hold the True RMS AC PCA in place by pulling the latches upward. (See Figure 809-1E in Section 8.)
3. Disconnect the red ac input lead from both the True RMS AC PCA and the Main PCA.

4. Position the True RMS AC PCA vertically as shown in Figure 6-20 and latch it in place by pressing the bottom two nylon latches into the specially provided mounting supports on the chassis.
5. Connect the Main PCA ac take-off point (stud connector W301) to the True RMS AC PCA input (the stud connector labeled AC IN) with a 6-inch jumper (E-Z-Hook 204-6W-S or equivalent).

6-73. MAJOR PROBLEMS

The signal flow through the True RMS AC option is straightforward, with no feedback paths between individual stages. This simplifies troubleshooting and often makes it possible to isolate a single defective stage without removing the instrument cover.

Test the mid-frequency response of the VAC function around 1 kHz. If an accurate reading can be obtained on at least one range, the rms converter (U802) is working properly. Test the high-frequency response around 100 kHz. If, after calibration, an accurate reading can be obtained on at least one range, the digitally controlled filter (U801, U808, R832, and C826-829) is OK. If some ranges are good and others are bad, the defective stage may be isolated using Table 6-26. If this table is used, the bad ranges must correspond exactly to the ranges listed in the first column and all other ranges must be good.

Most ac troubleshooting can be performed with the shields removed. To remove both shields, unscrew the Phillips screw on the back of the True RMS AC PCA. The only time it should be necessary to work on the PCA with the shields in place is when there is subtle high-frequency (>20 kHz) or low-level (<10 mV) error. In that case, the PCA should be left in its operating position, and the test points probed from the foil side of the PCA. Test points are labeled on both sides to facilitate such troubleshooting.

Table 6-26. Isolating a Defective AC Stage

DEFECTIVE RANGES	DEFECTIVE STAGE
200 mV, 2000 mA	U806B
20V, 700V	U806A
2V, 200V	U806A
200V, 700V	Input (Q806, K802, Z801)
2V, 20V, 200V	Input (Q806, K802, Z801)

If no ranges work, the signal should be traced from input to output. At any point where the signal disappears, the preceding stage should be searched thoroughly. To trace the signal, lock the instrument into one range (200 mV is usually a good choice) and apply the appropriate voltage shown in Table 6-27 to the HI and LO INPUT terminals. The input voltage should appear unchanged at pin Z801-1, and should appear at TP801 and TP802 as shown in Table 6-27. If no ranges work, it is likely that the rest of the scaling circuitry (U806B) is functional.

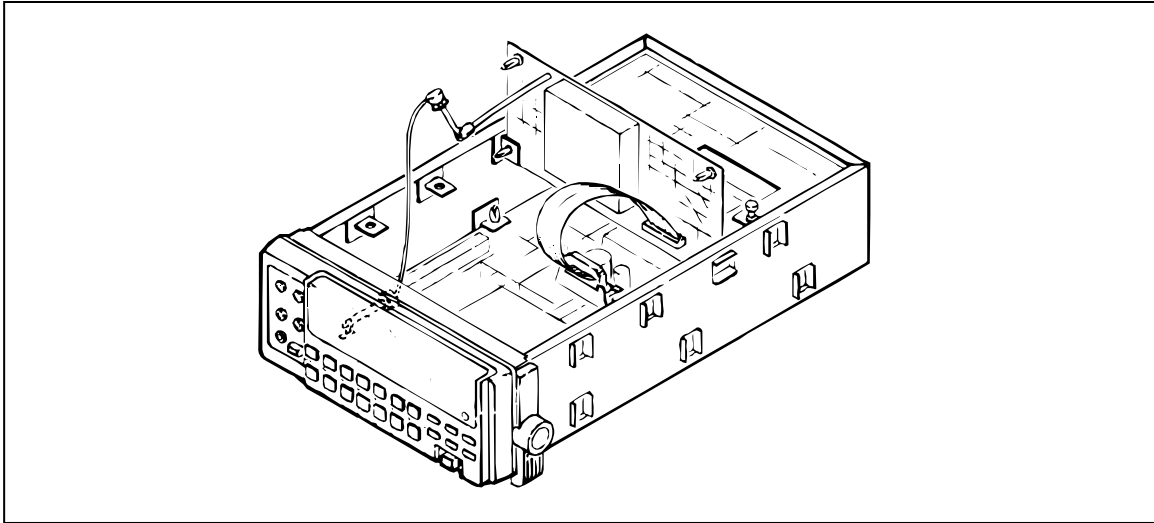

Figure 6-20. Option -09 Service Position

f6-20.wmf

If the signal at the input to U801A (pin 5) is incorrect, U804 may be defective, or the switch codes may be wrong. If the latter problem is suspected, refer to Table 6-28 and test the control lines to U804 (U804-1, 8, 9, 16). If a logic error is found, it may be due to excessive loading or a faulty data latch (U803), or other cabling or main-board digital problems. High-frequency oscillation problems are usually caused by switches being on when they should be off, resulting in positive feedback loops being closed around portions of the scaling circuitry.

Table 6-27. AC Signal Tracing

RANGE	INPUT VOLTAGE (1 kHz)	VOLTAGE AT TP801	VOLTAGE AT TP802
200 mV	100 mV	20 mV	1 V
2V	1V	200 mV	1 V
20V	10V	2V	1V
200V	10V	20 mV	100 mV
700V	100V	200 mV	100 mV

If the signal at TP802 is incorrect, but U801-5 is OK, the digitally controlled filter section (U801A and U808) is probably defective.

Table 6-28. Truth Table for U804 and K2

RANGE	PIN OR DEVICE				
	U804-1	U804-8	U804-9	U804-16	K2
2000 mA	1	0	1	1	0
200 mV	1	0	0	1	0
2V	1	1	1	0	0
20V	0	1	1	1	0
200V	1	1	1	0	1
700V	0	1	1	1	1
NOTE: For U804, logic 0 = switch on. Logic 1 is >2.4V; logic 0 is <0.8V.					

If the signal at TP802 is correct but the output signal (TP803) is incorrect, the rms converter is probably the source of the problem. Problems with U802 generally show up as an identical number of counts displayed in all ranges or as an overrange in all ranges. First isolate faults in the buffer amplifier (U802A) by ascertaining that the signal at U802-13 is the same as that at TP802 when each is observed with an ac-coupled oscilloscope, and that the dc offset at U802-13 is less than 4 mV. It is possible that a component in the loop filter (U809A and associated passive components) or the post-filter (U809B and associated passive components) is defective. The dc voltage at U802-6 should be the same as that at TP803 for frequencies above 500 Hz, and should be equal to the rms value of the input signal.

6-74. MORE OBSCURE PROBLEMS

Slow settling time or excessive jitter for low-frequency inputs is caused by rms converter loop errors. The cause may be a fault in the rms converter or loop filter.

If the output voltage is stuck at the supply rails, the cause is probably a fault in the rms converter. A less common cause is op amp oscillation; this can be checked with a scope at TP802.

If one or more ranges are functional but cannot be calibrated at high frequencies, then either the digitally controlled filter (U801B, R832, and C826-C829) is defective, or a defective component elsewhere in the circuit has rendered the response out of calibration range. (The high-frequency calibration is designed to cover the range of error expected due to op amp variations, input dividers, PCA tolerances, shielding, etc.). A sweep generator is useful in troubleshooting difficult frequency response problems.

The calibration control lines to U808 are set by software to store a high-frequency correction factor for each range. A state table cannot be given for these signals, but common sense will indicate if they are reasonable. For example, if all lines are at logic 0 for all ranges, something is probably wrong. Suspect U803, U808, or digital hardware on the Main PCA. If the control signals do indeed change with range, U808 or some part of the digitally controlled filter (U801B, R832, and C826-C829) may be defective. Even with the worst possible error in the high-frequency calibration code, the reading should be within 10% of the correct value at frequencies up to 100 kHz. If the error is larger, there are analog problems.

It is safe to force one control line at a time high (+5V) or low (0V) to test the individual switches in U808. (The on resistance of switches in U808 should be less than 500 Ω ; the off resistance should be greater than 10 M Ω .) Forcing the control lines high or low should cause the reading to change when the voltages in Table 6-27 are applied to the input terminals at 100 kHz. If only certain ranges cannot be calibrated, refer to Table 6-26 to find the suspected stage.

6-75. Guard Crossing Troubleshooting

To troubleshoot the Guard Crossing circuit, place the 8842A in the In-Guard Troubleshooting Mode as described under Digital Controller Troubleshooting, earlier in this section. This causes the In-Guard μ C to send a test pattern to the IEEE-488 Interface PCA via one-half of the Guard Crossing circuit. You should be able to observe the waveforms shown in the left half of Figure 6-21.

To troubleshoot the second half of the Guard Crossing circuit, leave the 8842A in the In-Guard Troubleshooting Mode. This causes the IEEE-488 Interface PCA to send a test pattern to the In-Guard μ C. You should be able to observe the waveforms shown in the right half of Figure 6-21. The IEEE-488 Interface PCA sends the test pattern in response to the test pattern sent by the In-Guard μ C; therefore, the first half of the Guard Crossing Circuit (which was tested in the previous paragraph) must be working properly before the second half can be tested.

6-76. INTERNAL CLEANING

CAUTION

Failures due to electrostatic discharge can be caused by improper handling of the PCAs and by the use of a vacuum cleaner with static-inducing brushes. To prevent damage by electrostatic discharge, observe the precautions described on the Static Awareness sheet in front of this section.

If visual inspection of the instrument shows excessive dirt build-up in the instrument, clean the appropriate section using clean, oil-free, low-pressure air (less than 20 psi). If necessary, remove the option PCAs first.

6-77. Cleaning Printed Circuit Assemblies

If conditions warrant, individual printed circuit assemblies (PCAs) can be cleaned with water-based commercial cleaning systems such as dishwashers. If such systems are used, observe the following precautions:

1. Remove all shield covers (applies to the True RMS AC PCA) and socketed ICs.
2. Use Reagent Grade 2 or better water (de-ionized or distilled water) for the final rinse in geographic areas with exceptionally hard water. During the final rinse, spray or run the water so that the surface is thoroughly covered to remove all ionized material.
3. Thoroughly dry all PCAs using one of the following methods:
 - a. Preferably, the PCA should be dried in a low-temperature drying chamber or infrared drying rack with a temperature range of 49°C to 72°C (120°F to 160°F).
 - b. If neither a drying chamber nor a drying rack is available, air dry the PCA at ambient room temperature for at least two days.

A satisfactory cleaning method consists of holding the PCAs under hot running water until they are clean. Follow this wash with a final rinse. (See consideration 2, above.)

6-78. Cleaning After Soldering

CAUTION

T.M.C. Cleaner and similar products can attack the nylon latches and other plastic pieces.

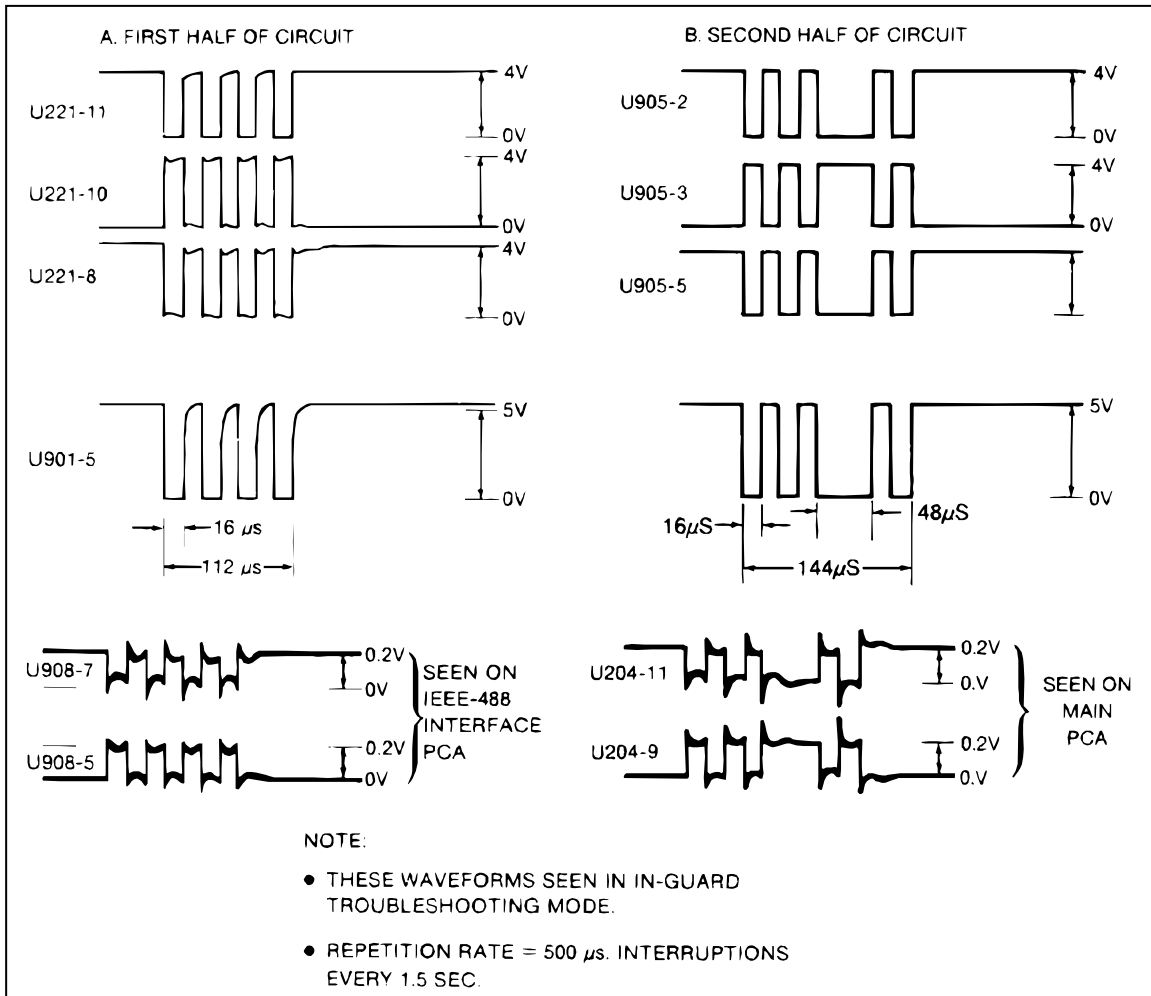

i6-21.wmf

Figure 6-21. Guard Crossing Test Waveforms

If a PCA has been soldered, it should first be cleaned with SPRAYON T.M.C Cleaner™ (rosin flux remover) or equivalent. The PCA should then be cleaned with water as described above.

Chapter 7

List of Replaceable Parts

	Title	Page
7-1.	INTRODUCTION.....	7-3
7-2.	HOW TO OBTAIN PARTS.....	7-3
7-3.	MANUAL STATUS INFORMATION.....	7-3
7-4.	NEWER INSTRUMENTS.....	7-4
7-5.	SERVICE CENTERS.....	7-4

7-1. INTRODUCTION

This section contains an illustrated list of replaceable parts for the 8842A. Parts are listed by assembly; alphabetized by reference designator. Each assembly is accompanied by an illustration showing the location of each part and its reference designator. The parts lists give the following information:

- Reference designator
- An indication if the part is subject to damage by static discharge
- Description
- Fluke stock number
- Manufacturers supply code (code-to-name list at the end of this section)
- Manufacturers part number or generic type
- Total quantity
- Any special notes (i.e., factory-selected part)

CAUTION

A * symbol indicates a device that may be damaged by static discharge.

7-2. HOW TO OBTAIN PARTS

Electrical components may be ordered directly from the manufacturer by using the manufacturers part number, or from the Fluke Corporation and its authorized representatives by using the part number under the heading FLUKE STOCK NO. In the U.S., order directly from the Fluke Parts Dept. by calling 1-800-526-4731. Parts price information is available from the Fluke Corporation or its representatives. Prices are also available in a Fluke Replacement Parts Catalog which is available on request.

In the event that the part ordered has been replaced by a new or improved part, the replacement will be accompanied by an explanatory note and installation instructions, if necessary.

To ensure prompt delivery of the correct part, include the following information when you place an order:

- Instrument model and serial number
- Part number and revision level of the pca containing the part
- Reference designator
- Fluke stock number
- Description (as given under the DESCRIPTION heading)
- Quantity

7-3. MANUAL STATUS INFORMATION

The Manual Status Information table that precedes the parts list defines the assembly revision levels that are documented in the manual. Revision levels are printed on the component side of each pca.

7-4. NEWER INSTRUMENTS

Changes and improvements made to the instrument are identified by incrementing the revision letter marked on the affected pca. These changes are documented on a supplemental change/errata sheet which, when applicable, is included with the manual.

7-5. SERVICE CENTERS

A list of service centers is located at the end of this section.

NOTE

This instrument may contain a Nickel-Cadmium battery. Do not mix with the solid waste stream. Spent batteries should be disposed of by a qualified recycler or hazardous materials handler. Contact your authorized Fluke service center for recycling information.

WARNING

THIS INSTRUMENT CONTAINS A FUSIBLE RESISTOR (PN 733915). TO ENSURE SAFETY, USE EXACT REPLACEMENT ONLY.

Manual Status Information

REF OF OPTION NO.	ASSEMBLY	FLUKE PART NO.	REVISION LEVEL
A1	Main PCA	759365	BE
A2	Display PCA	728873	—
05	IEEE-488 Interface PCA	879267	D
09	True RMS AC PCA	759266	N

Table 7-1. 8842A Digital Multimeter

REFERENCE DESIGNATOR	DESCRIPTION	FLUKE STOCK NO	MFRS SPLY CODE	MANUFACTURERS PART NUMBER OR GENERIC TYPE	TOT QTY	NOTES
A 1	‡ MAIN PCA	759365	89536	759365	1	
A 2	‡ DISPLAY PCA	728873	89536	728873	1	
F 301	FUSE, .406, 1.375, 3A, 600V, FAST	475004	71400	BBS-3	1	
F 302	FUSE, .25X1.0, 2A, 250V, FAST	376582	71400	AGX-2	1	
F 601	FUSE, .25X1.25, 0.25A, 250V, SLOW	166306	71400	MDA-1/4	1	
FL 1	FILTER, LINE, 250VAC-3A, IEC RECEPTACLE	721274	54583	ZUB2203-00	1	
H 11	SCREW, PH, P, LOCK, STL, 6-32, .250	152140	73734	19042	1	
H 13, 35	SCREW, TH, P, SS, 4-40, .187	721118		COMMERCIAL	2	
H 14, 36	SCREW, FIH, P, STL, 8-32, .500	721134		COMMERCIAL	2	
H 15, 37- 39	SCREW, PH, P, THD FORM, STL, 4-20, .500	721449		COMMERCIAL	4	
H 17	SCREW, FHU, P, LOCK, SS, 6-32, .250	320093	74594	320093	1	
H 18, 40	SCREW, FH, P, LOCK, STL, 8-32, .375	114116	89536	114116	2	
H 19, 41	SCREW, PH, P, LOCK, STL, 4-40, .312	152116	73734	19023	2	
H 20	SCREW, PH, P SEMS, STL, 4-40, .375	281196		COMMERCIAL	1	
H 22, 10, 34	NUT, EXT LOCK, STL, 6-32, .3440D	152819	78189	501-060800-00	3	
H 24	SPACER	735407		COMMERCIAL	1	
H 25	SPACER	735415		COMMERCIAL	1	
H 27, 28	SCREW, FH, P, LOCK, STL, 6-32, .750	114504	73734	18248	2	
H 58, 59	SPACER, RND, NYL, .166, .250	772889	55566	11558N	2	
H 66, 67	NUT, CAP, EXT. LOCK, STL, 4-40	195255	78189	501-040800-00	2	
H 68, 69	CONN ACC, MICRO-RIBBON, SCREW LOCK	854737	05791	LT43026	2	
MP 1	‡ SHIELD MAIN BOTTOM	728998	89536	728998	1	
MP 3	CASE, METAL	656389	89536	656389	1	
MP 4	FRONT PANEL, MODIFIED	759241	89536	759241	1	
MP 5	PUSHROD, POWER	656413	89536	656413	1	
MP 6	PUSH ROD RAI	656488	89536	656488	1	
MP 7	PUSH ROD CAL ENABLE SWITCH	684142	89536	684142	1	
MP 8	MOUNTING PLATE, HANDLE (LEFT)	729004	89536	729004	1	
MP 9	MOUNTING PLATE, HANDLE (RIGHT)	660472	89536	660472	1	
MP 10	HANDLE, PAINTED, BLACK	810127	89536	810127	1	
MP 11	BEZEL, REAR	660480	89536	660480	1	
MP 12	SPACER, MATRIX	684126	89536	684126	1	
MP 13, 56	CASE, FOOT, BLACK	824433	89536	824433	2	
MP 14	CHASSIS ASSEMBLY	684134	89536	684134	1	
MP 15	TERMINAL BLOCK, RAI	656504	89536	656504	1	
MP 16	SEAL, CALIBRATION	735274	22670	735274	1	
MP 17, 37- 49	SUPPORT, FWB	683987	89536	683987	14	
MP 18	LENS, FRONT PANEL	759274	89536	759274	1	
MP 19	DECAL, FRONT	685081	89536	685081	1	
MP 20	DECAL, REAR	765487	89536	765487	1	
MP 21	‡ NSERT, REAR PANEL	684191	89536	684191	1	
MP 22	IEEE CABLE GUIDE	728956	89536	728956	1	
MP 23	DECAL CSA	525527	22670	525527	1	
MP 26, 50- 52	SHIELD, SUPPORT	735308	89536	735308	4	
MP 27	HLDR PART, FUSE, CAP, 1/4X1-1/4	460238	61935	031.1666	1	
MP 32	FUSE HOLDER/CAP ASSEMBLY	516039	89536	516039	1	
MP 57	NAMEPLATE, SERIAL, -REAR PANEL-	472795	85480	472795	1	
MP 58	BRACKET, TRANSFORMER	765263	89536	765263	1	
MP 60- 65	RIVET, PUSH, TH, NYL, .620 L	852173	89536	852173	6	
S 1	KEYPAD, CONDUCTIVE, ELASTOMERIC	745638	89536	745638	1	
S 602, 603	‡ LINE VOLTAGE SELECTION SWITCH	735258	89536	735258	2	
TM 1	INSTRUCTION MANUAL	879309	89536	879309	1	
TM 2	GETTING STARTED MANUAL	879291	89536	879291	1	
W 4	CORD, LINE, R/A 5-15/IEC, 3-18AWG, SVT	707018	0B445	ECM-490-BLACK	1	
W 7	TEST LEAD ASSY, TL70A	855820	89536	855820	1	
W 9	WIRE ASSY, AC CONNECT	684316	89536	684316	1	
NOTES:	‡ Static sensitive part.					

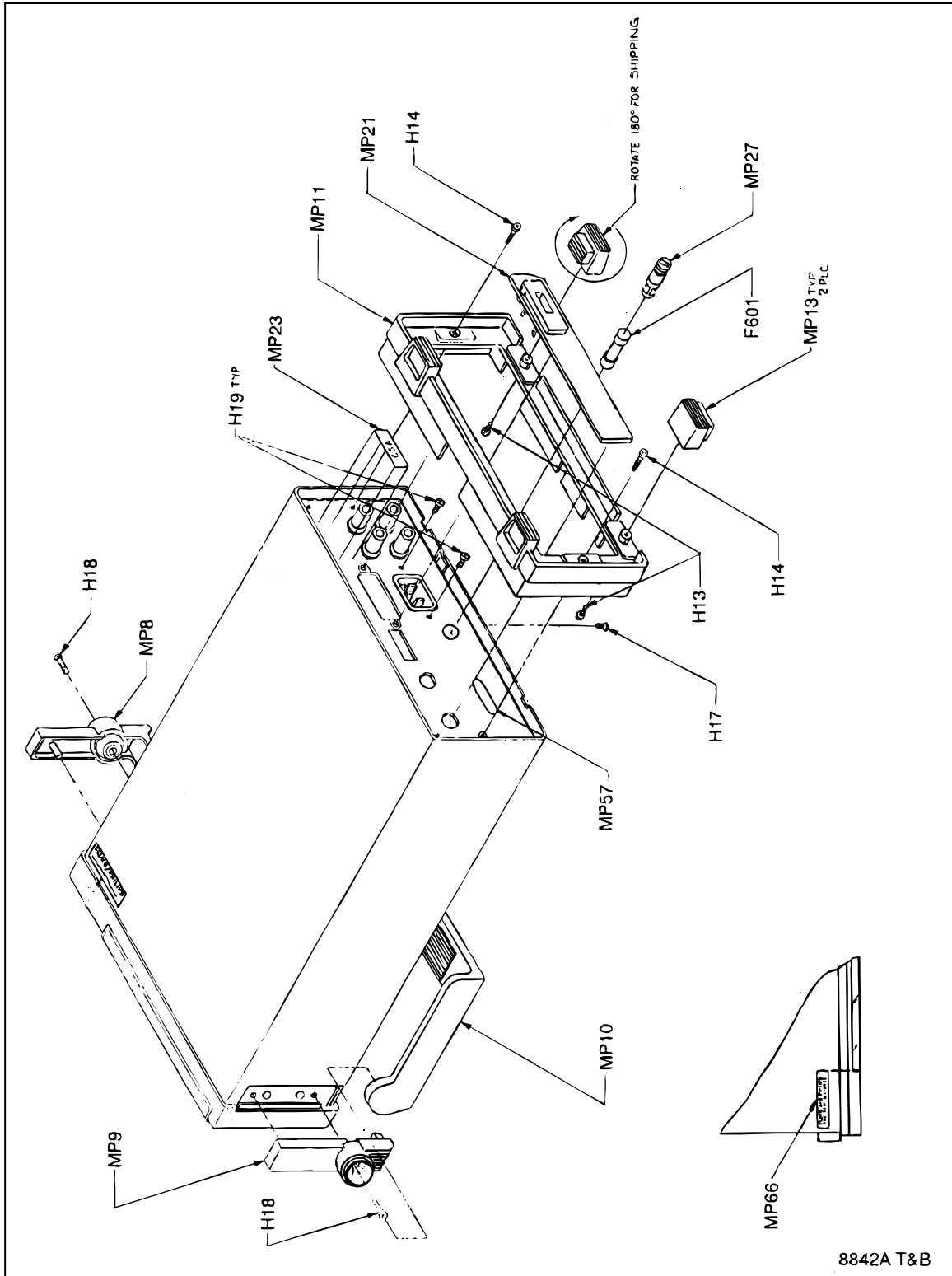

Figure 7-1. 8842A Digital Multimeter

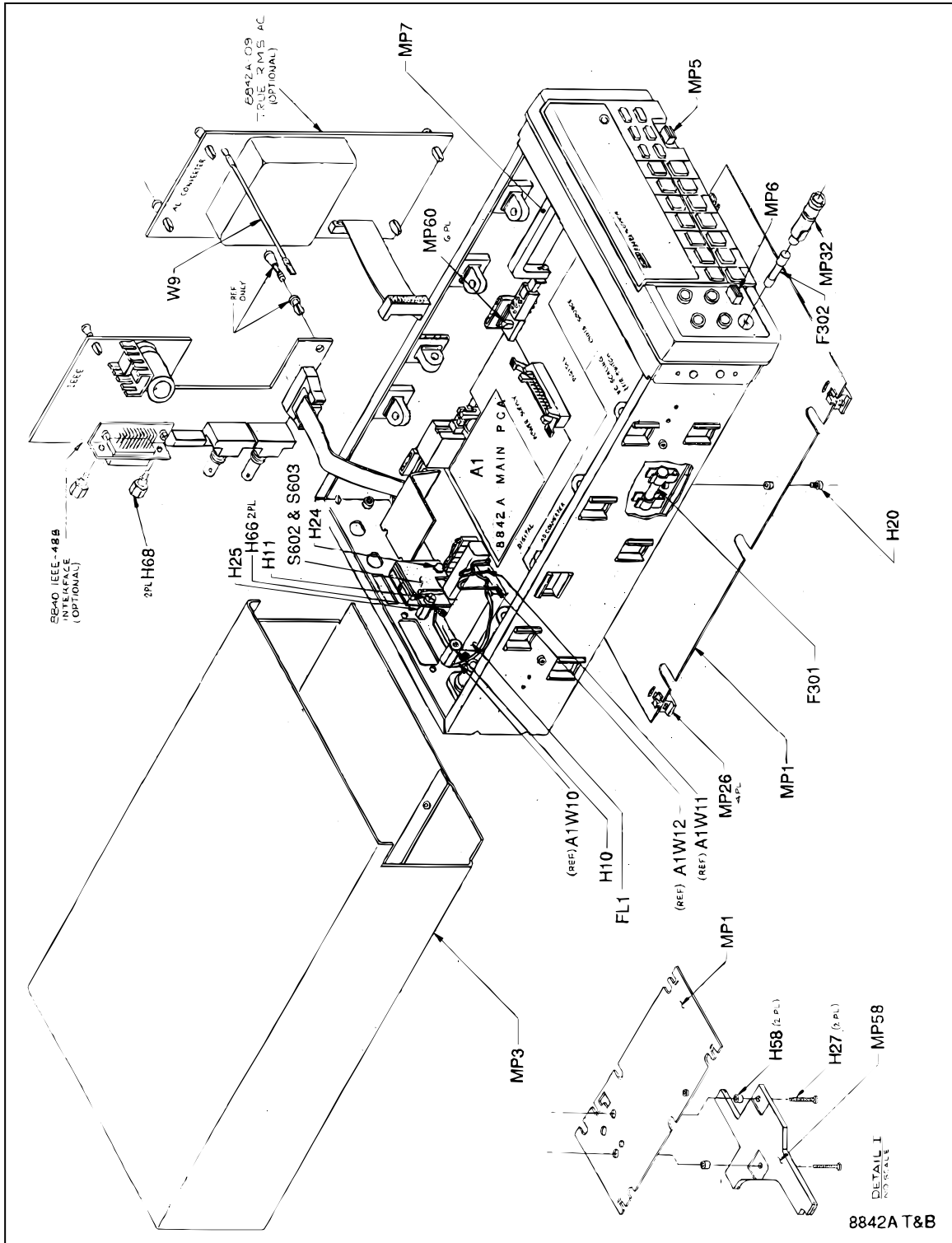
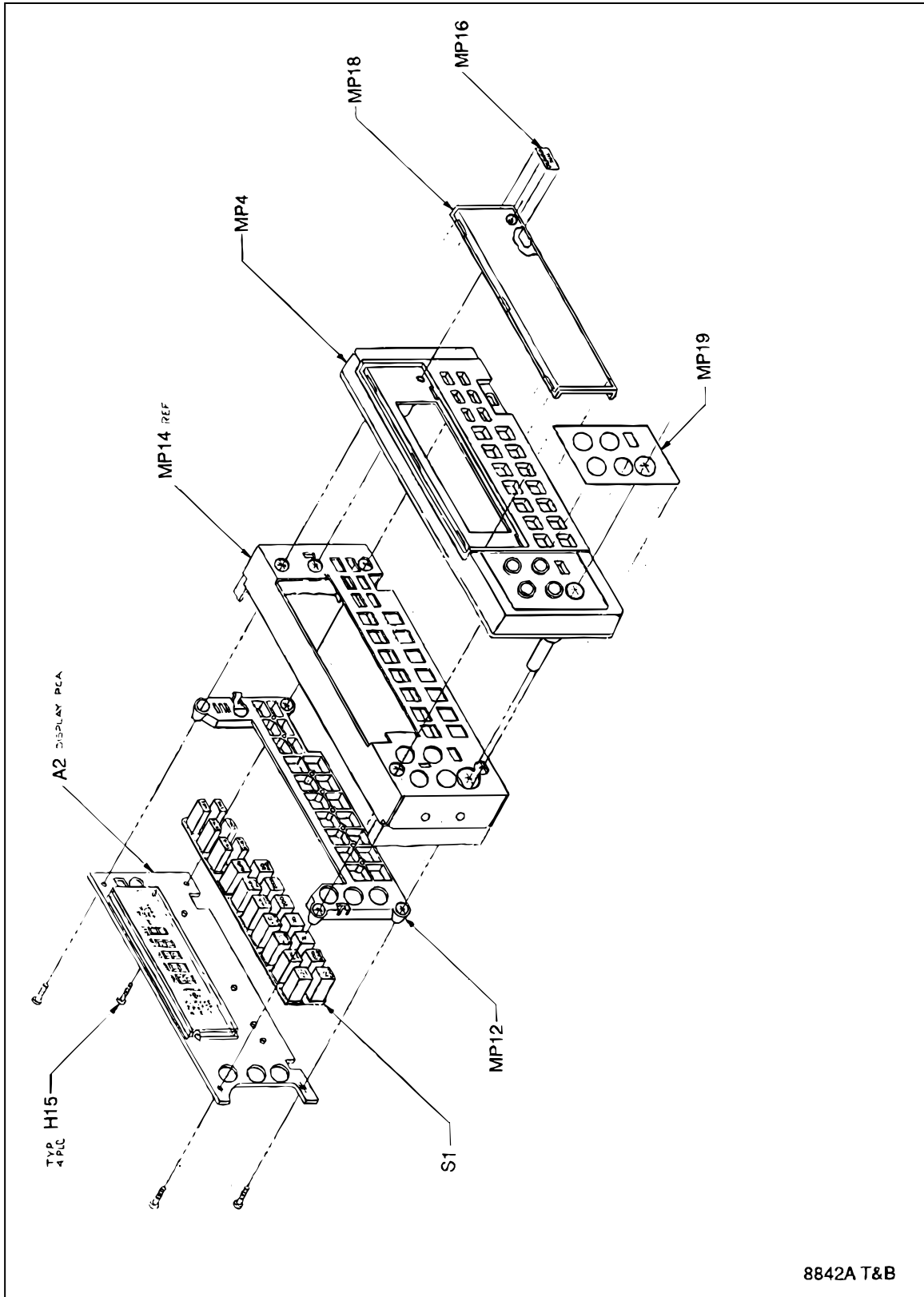

Figure 7-1. 8842A Digital Multimeter (cont)

f7-01_2.wmf



8842A T&B

f7-01_3.wmf

Figure 7-1. 8842A Digital Multimeter (cont)

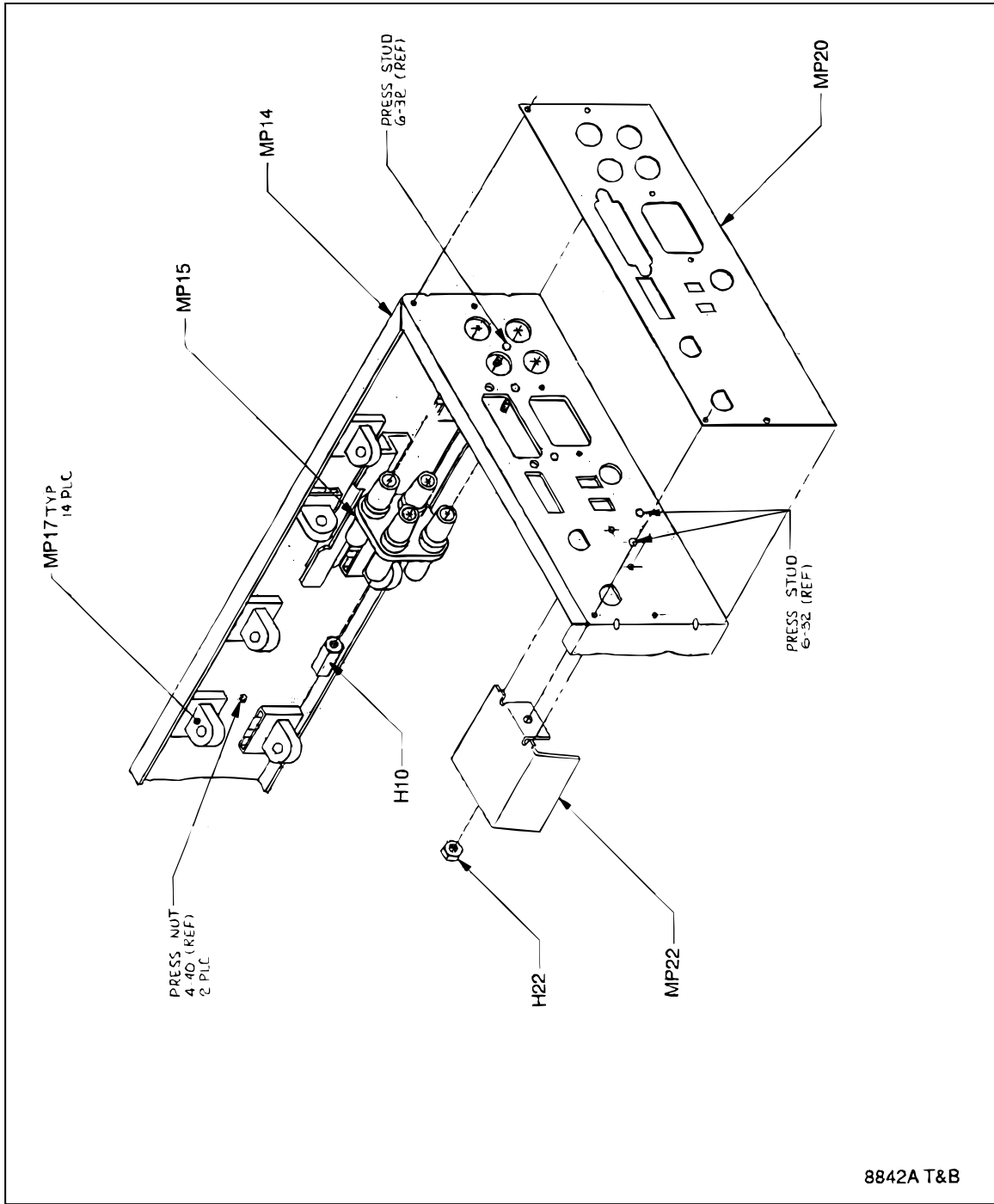

Figure 7-1. 8842A Digital Multimeter (cont)

Table 7-2. A1 Main PCA

Reference Designator	Description	Fluke Stock No	Tot Qty	Notes
AR701	REF AMP SET	759290	1	
C101-103,C311	CAP,POLYPR,0.1UF,+/-10%,160V	446781	4	
C104,C105,C205-209,C304,C305,C315,C404,C604,C606,C609,C610	CAP,CER,0.22UF,+80-20%,50V,Z5U	733386	15	
C202,C203,C617,C618	CAP,CER,0.01UF,+80-20%,50V,Z5V	733386		
C204,C602,C608,C612	CAP,TA,1UF,+20%,35V	733386		
C210	CAP,CER,1000PF,+20%,50V,X7R	697284	4	
C301,C302	CAP,TA,1UF,+20%,35V	697284	4	
C303	CAP,CER,1000PF,+20%,50V,X7R	697417	4	
C306	CAP,POLYPR,0.33UF,+/-10%,160V	697417	4	
C307	CAP,POLYPR,0.33UF,+/-10%,160V	697458	1	
C308	CAP,POLYPR,0.22UF,+/-10%,160V	520346	2	
C309	CAP,POLYPR,0.22UF,+/-10%,160V	715284	1	
C310	CAP,POLYPR,4700PF,+/-10%,63V	446799	7	
C312	CAP,POLYPR,0.47UF,+/-10%,160V	721662	t	
C314	CAP,POLYPR,0.47UF,+/-10%,160V	446807	1	
C402	CAP,CER,120PF,+/-5%,50V,C0G	721142	1	
C403	CAP,CER,120PF,+/-5%,50V,C0G	721142	1	
0601	CAP,POLYPR,0.001UF,+/-10%,50V	720938	1	
C603	CAP,POLYPR,0.047UF,+/-10%,160V	446773	1	
C605,C607	CAP,CER,330PF,+/-5%,50V,C0G	697441	1	
C611	CAP,POLYPR,0.47UF,+/-10%,50V	697409	1	
C701	CAP,AL,6800UF,+/-20%,16V	478784	1	
CL301	CAP,AL,330UF,+50-20%,100V	484436	1	
CR101,CR102,CR201,CR202,CR306,CR307,CR309,CR311-313	CAP,AL,470UF,+20%,50V,SOLV PROOF	747493	2	
CR103,CR104,CR613	CAP,AL,100UF,+50-20%,50V	649731	1	1
CR105,CR106,CR203-206,CR301,CR302,CR401,CR404,CR615,CR701	CAP,CER,270PF,+/-5%,50V,C0G	658898	1	
CR303	* I-REG DIODE,0.43MA,20%,SEL,TO-0226AC	707836	1	
CR304,CR305	ZENER,UNCOMP,3.9V,10%,20.0MA,0.4W	113316	10	
CR308,CR310	ZENER,UNCOMP,3.9V,10%,20.0MA,0.4W	113316		
CR402,CR403	ZENER,UNCOMP,3.9V,10%,20.0MA,0.4W	113316		
CR405	ZENER,UNCOMP,3.9V,10%,20.0MA,0.4W	113316		
CR601-606,CR608-611	* ZENER,UNCOMP,7.5V,5%,20.0MA,0.4W	256446	3	
CR607,CR612	* ZENER,UNCOMP,7.5V,5%,20.0MA,0.4W	256446		
CR614	* DIODE,SI,BV=75V,10=150MA,500MW	203323	12	
CR616	* DIODE,SI,BV=75V,10=150MA,500MW	203323		
CR617	* DIODE,SI,BV=75V,10=150MA,500MW	203323		
H1,H51	* DIODE,SI,BV=75V,10=150MA,500MW	203323		
H3	* ZENER,UNCOMP,10.0V,5%,12.5MA,0.4W	246611	1	
H5	* ZENER,UNCOMP,6.8V,5%,20.0MA,0.4W	260695	2	
H6	* ZENER,UNCOMP,24.0V,5%,5.2MA,0.4W	267807	2	
H12	DIODE,SI,1K PIV,1.0AMP	707075	2	
J201	* ZENER,UNCOMP,5.1V,5%,20.0MA,0	159798	1	
J202	DIODE,S1,100 PIV,1 AMP	742874	70	
	DIODE,S1,100 PIV,1 AMP	742874		
	* ZENER,UNCOMP,6.2V,5%,20.0MA,0.4W	325811	2	
	* ZENER,UNCOMP,8.2V,5%,20.0MA,0.4W	386771	1	
	ZENER,UNCOMP,56.0V,5%,2.2MA,0.4W	187757	1	
	ZENER,UNCOMP,8.2V,5%,20.0MA,0.4W	386771	1	
	RIVET,S-TUB,OVAL,STL,.118,.156	103424	2	
	NUT,BROACH,STL,4-40	380196	1	
	NUT,HEX,STL,4-40	110635	1	
	SCREW,PH,P,SEMS,STL,6-32,.250	178533	1	
	SCREW,PH,P,SEMS,STL,4-40,.250	185918	1	
	HEADER,2 ROW,.100CTR,20 PIN	706986	1	
	CABLE ASSY,FLAT,10 CONDUCT,6.0	714022	1	

Table 7-2. A1 Main PCA (cont)

Reference Designator	Description	Fluke Stock No	Tot Qty	Notes
J203,J204	CABLE, DISPLAY	684167	2	
J602	HEADER,1 ROW,.156CTR,6 PIN	380378	1	
JPR001,JPR002	RES JUMPER,0.02,0.25W	682575	2	
K301	RELAY,ARMATURE,2 FORM C,5VDC	615575	1	
K401	RELAY,REED,1 FORM A,5V,HIGH VOLTAGE	714352	1	
MP2	INSUL PT,TRANSISTOR MOUNT,DAP,TO-5	152207	1	
MP29,MP50	HLDR,FUSE,13/32,PWB MT	516880	2	
MP30	SHIELD, AID	728907	1	
MP33	HEAT DIS,VERT,1.18X1.00X0.50,TO-220	414128	1	
MP35	HLDR PART,FUSE,BODY,PWB MT	602763	1	
MP201	PAD, ADHESIVE	735365	1	
Q101,Q309,Q318, Q408	* TRANSISTOR,SI,NPN,60V,1W,TO-92	698225	4	
Q102,Q319	* TRANSISTOR,SI,PNP,40V,350MW,TO-92	698233	2	
Q301, Q302,Q303,Q304, Q307,Q308,Q310	* TRANSISTOR,SI,N-JFET,TO-92	601333	17	
Q311,Q312,Q313, Q315,Q316,Q317, Q401,Q405-407	*	601333		
Q305	* TRANSISTOR,SI,NPN,300V,1W,TO-92	722934	1	
Q306,Q402-404	* TRANSISTOR,SI,PNP,350V,0.6W,SEL,TO-92	650846	4	
Q314	* TRANSISTOR,SI,N-JFET,DUAL,SEL,TO-71	461772	1	
Q320	* TRANSISTOR,SI,N-MOS,350MW,TO-92	783449	1	
Q601	* THYRISTOR,SI,SCR,VBO=100V,0.8A	742643	1	
R101,R602,R603, R605	RES,CF,1K,+5%,0.25W	343426	4	
R102,R203,R204	RES,CF,470,+5%,0.25W	343434	3	
R103,R104	RES,CF,27K,+5%,0.25W	441501	2	
R105	RES,MF,50K,+0.1%,0.125W,25PPM	340257	1	
R106	RES,CF,560,+5%,0.25W	385948	1	
R201,R215,R217, R305-307,R604	RES,CF,15K,+5%,0.25W	348854	7	
R202,R315,R327	RES,CF,100,+5%,0.25W	348771	3	
R205,R207,R208, R210,R412	RES,CF,1.5K,+5%,0.25W	343418	5	
R206,R209,R312, R313,R408	RES,CF,33K,+5%,0.25W	348888	5	
R216,R326,R406	RES,CF,2.4K,+5%,0.25W	441493	3	
R301	RES,CC,100K,+5%,2W	285056	1	
R302,R311,R324, R325	RES,MF,46.4K,+1%,0.125W,50PPM	715185	4	
R303	RES,MF,110K,+1%,0.125W,100PPM	234708	1	
R304	FIES,CF,1.5M,+5%,0.25W	349001	1	
R308,R316,R317, R323	RES,CF,1M,+5%,0.25W	348987	4	
R309	RES,MF,1K,+1%,0.5W,FLMPRF,FUSIBLE	733915	1	1
R310,R409,R415	RES,CF,5.6K,+5%,0.25W	442350	3	
R314	RES,CC,22K,+10%,2W	109975	1	
R318	RES,CF,620,+5%,0.25W	442319	1	
R319	W W RESISTOR	731950	1	
R321,R322	RES,MF,10K,+0.1%,0.725W,50PPM	343459	2	
R401	RES, WW, HERM, 1/4W, 54.6K, +/-0.5%	762120	1	
R402	RES,CF,4.3M,+5%,0.25W	543348	9	
R403	RES,CF,10M,+5%,.25W	875257	1	
R407	RES,CF,910,+5%,0.25W	442335	1	
R410	RES,MF,1K,+1%,100PPM,FLMPRF,FUSIBLE	474080	1	1

Table 7-2. A1 Main PCA (cont)

Reference Designator	Description	Fluke Stock No	Tot Qty	Notes
R413	RES,MF,4.99M,+1%,0.125W,100PPM	715060	1	
R414	RES,MF,576K,+1%,0.125W,100PPM	344291	1	
R416	RES,MF,100,+1%,0.125W,25PPM	460527	1	
R601	RES,CF,560,+5%,0.25W	385948	1	
RV301,RV401-404	VARISTOR,390V,+10%,1MA	697383	5	
RV601	VARISTOR,430V,+10%,1.0MA	519355	1	
S201	SWITCH,PUSHBUTTON,DPDT,PUSH-PUSH	875703	1	
S601	SWITCH,PUSHBUTTON,DPDT,PUSH-PUSH	453605	1	
T201,T202	TRANSFORMER, PULSE	660589	2	
T601	TRANSFORMER, POWER	803270	1	
TP101-105,TP201, TP202,TP204-207, TP301-304,TP401, TP403,TP601-605, TP607-609	TERM,FASTON,TA8,.110,SOLDER	512889	25	
U102,U702	* IC,OP AMP,DUAL,LO OFFST,VOLT,LO-DRIFT	685164	2	
U103	* IC,OP AMP,LO-OFF VOLTAGE,LO-DRIFT	685156	1	
U201	* IC,BIPLR,BCHNL DRIVER	685412	1	
0203	* IC,LSTTL,HEX INVERTER	393058	1	
U204,U305	* IC,COMPARATOR,QUAD,14 PIN DIP	387233	2	
U208	* IC,LSTTL,3-8 LINE DCDR W/ENABLE	407585	1	
U211	* IC,LSTTL,QUAD 2 INPUT OR GATE	393108	1	
0213	* IC,LSTTL,8BIT ADDRABLE LATCH,W/CLR	419242	1	
U215,U217,U218	* IC,BIPLR,8CHNL FLOURSCNT DISPLY DRIVR	685537	3	
0216	* IC,LSTTL,BCD TO 7 SEGMENT DCDR/DRVR	697730	1	
U219	* IC,CMOS,OCTL D F/F W/3-STATE,+EDG TRG	585364	1	
0221	* IC,LSTTL,HEX INVERTER W/SCHMT TRIG	483180	1	
U301-303,U402	* IC CMOS, QAS, PLASTIC, HIGH, B GRADE	700013	4	
U304	* IC,OP AMP,FET,LO NOISE,PRECISIION,8DIP	780759	1	
0306	* IC,OP AMP,SPECIAL,LOW DRIFT,TO-99	650713	1	
U307	* IC,OP AMP,JFET IN,COMPENSTD,8 PIN DIP	418780	1	
0401	* IC,OP AMP,LO-OFFSET VOLTAGE,LO-NOISE	605980	1	
U403	* IC CMOS, QAS, PLASTIC, HIGH, A GRADE	803478	1	
U404	* IC,OP AMP,GENERAL PURPOSE,8 PIN	478107	1	
VR601	* IC,VOLT REG,FIXED,+5 VOLTS,1.5 AMPS	428847	1	
VR602	* IC,VOLT REG,FIXED,+24 VOLTS,1.5 AMPS	604074	1	
VR603	* IC,VOLT REG,FIXED,+15 VOLTS,1.5 AMPS	413187	1	
VR604	* IC,VOLT REG,FIXED; 15 VOLTS,1.5 AMPS	413179	1	
VR605	* IC,VOLT REG,FIXED, 24 VOLTS,1.5 AMPS	418251	1	
W1,W8	WIRE ASSEMBLY, GUARD CROSSING	684399	2	
W2,W9	WIRE ASSY, GUARD CROSSING	728840	2	
W5	HARNESS, ANALOG FRONT	765297	1	
W6	HARNESS, ANALOG REAR	765305	1	
W10	CABLE, LINE VOLTAGE-GROUND	873740	1	
W11	CABLE, LINE VOLTAGE-LINE	873745	1	
W12	CABLE, LINE VOLTAGE-NEUTRAL	873752	1	
XU101,XU102, XU212	SOCKET,JC,40 PIN,DUAL WIPE,RET	756668	3	
XU220	SOCKET,IC,24 PIN,DUAL WIPE,BEAM TYPE	756650	1	
XU222		756353	1	
Y201	CRYSTAL,8.00MHZ QUARTZ HC-18U	707133	1	
Z101	RNET,MF,HERM,SIP,8842 A TO D CONV	755983	1	
Z301,Z303	* RNET,MF,HERM,SIP,8842 LO V DIVIDER	755934	2	
Z302	* RNET,MF,HERM,SIP,8842 HI V DIVIDER	756130	1	
Z304,Z402	* RNET,CERM,SIP,8840 HI V PROTECT	715789	2	
Z401	* RNET,MF,HERM,SIP,LO V 1 SOURCE	755884	1	
Z702	* RNET,MF,HERM,SIP,8842 LO V DIVIDER	756080	1	

1. FUSIBLE RESISTOR. TO ENSURE SAFETY, USE EXACT REPLACEMENT ONLY.

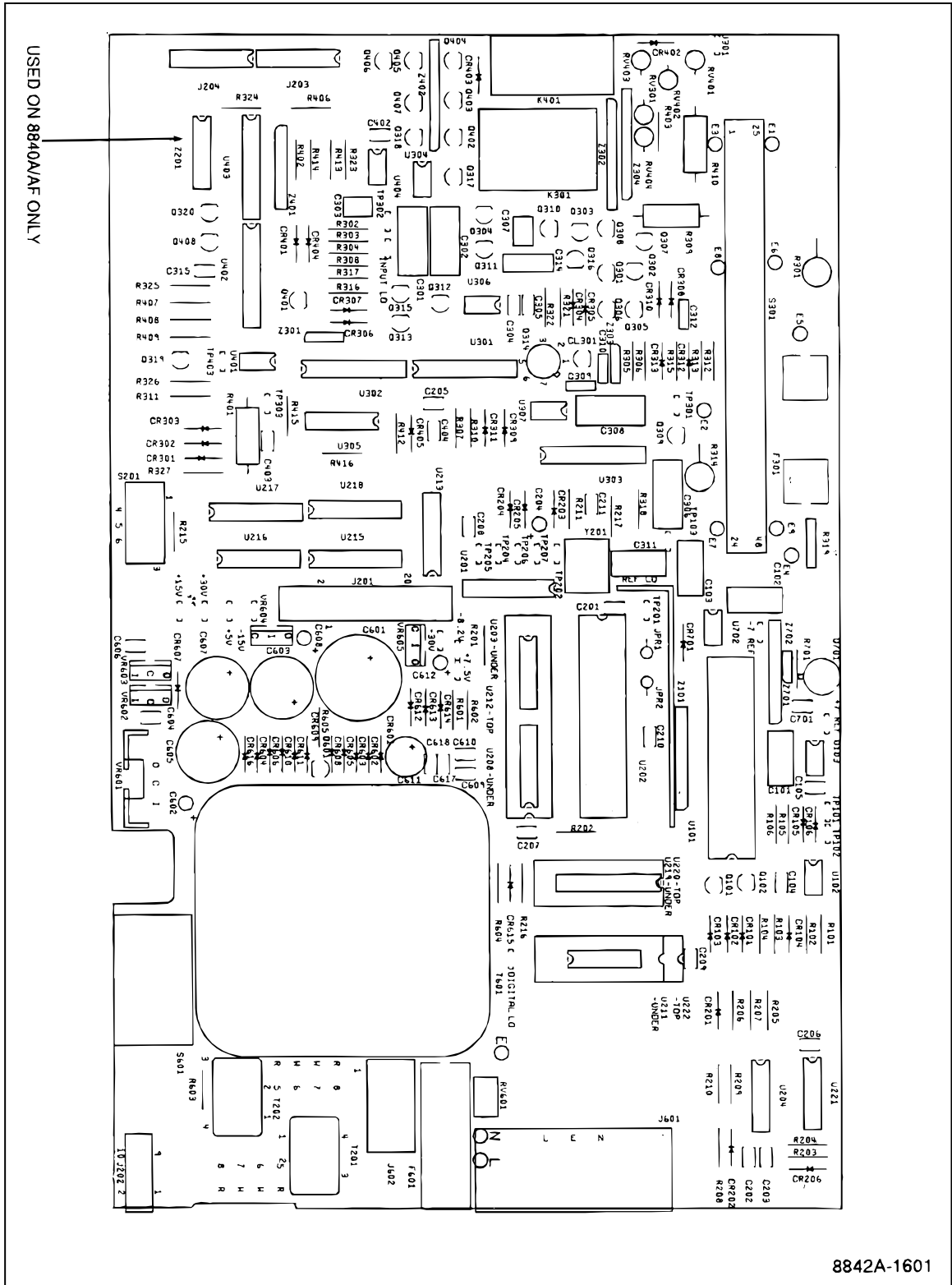

8842A-1601

f7-03.wmf

Figure 7-2. A1 Main PCA

Table 7-3. A2 Display PCA

REFERENCE DESIGNATOR	DESCRIPTION	FLUKE STOCK NO	MFRS SPLY CODE	MANUFACTURERS PART NUMBER OR GENERIC TYPE	TOT QTY	NOTES
DS 1	DISPLAY, VACUUM FLUORESCENT	680843	89536	680843	1	
MP 4- 7	PAD, ADHESIVE	735365	21958	735365	4	
XU 203,204	SOCKET, IC, 16 PIN	291534	91506	216AG-39D	2	
NOTES:	† Static sensitive part.					

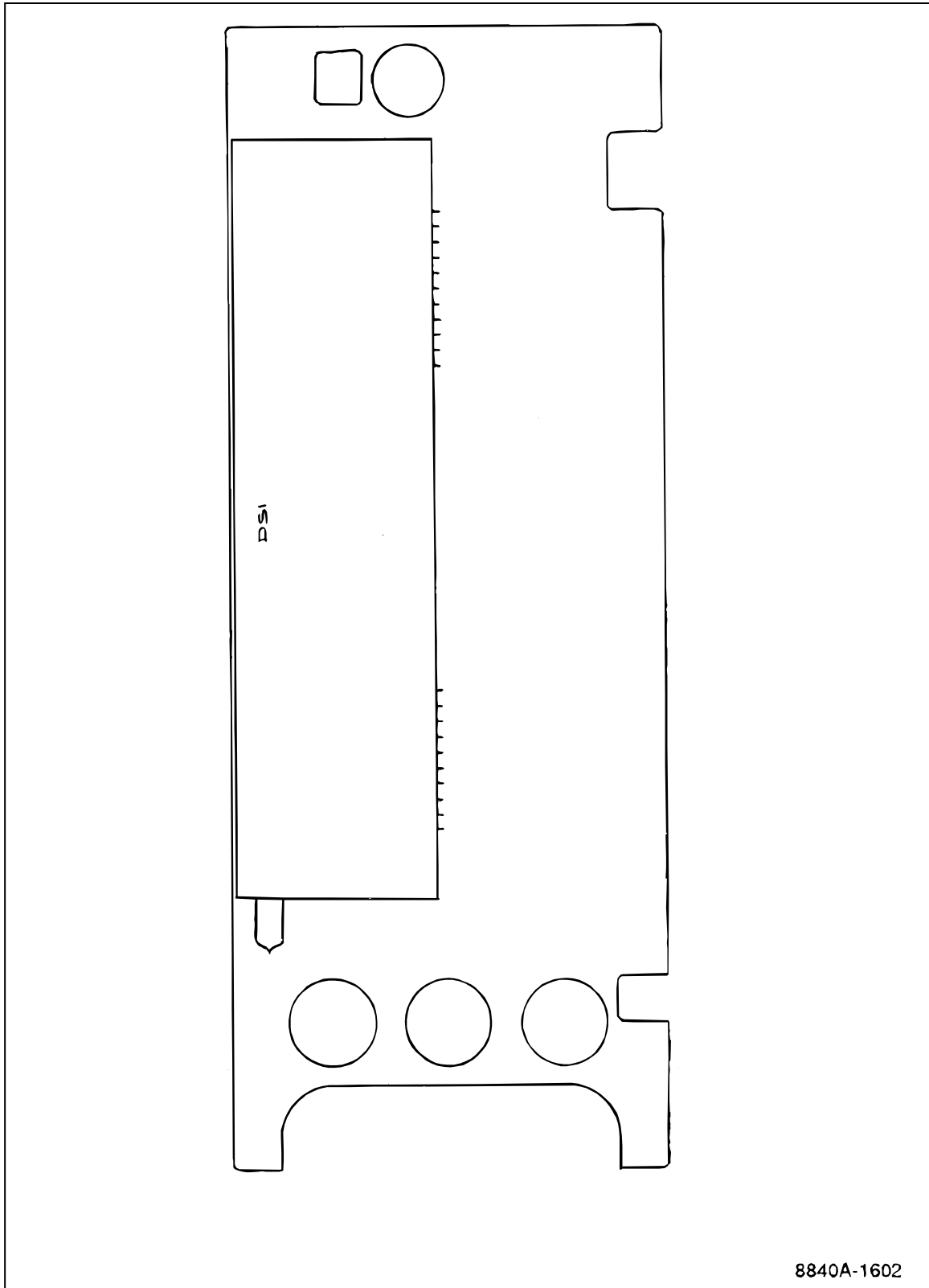

Figure 7-3. A2 Display PCA

f7-03.wmf

Supply Codes for Manufacturers

00779 AMP, Inc. Harrisburg, PA	13919 Burr-Brown Corp. Tucson, AZ	31918 ITT/Schadow Inc. Eden Prairie, MN
01121 Allen-Bradley Co. Milwaukee, WI	14329 Wells Electronics Inc. South Bend, IN	34649 Intel Corp. Santa Clara, CA
01295 Texas Instruments Inc. Semiconductor Group Dallas, TX	15636 Elec-Trol Inc. San Diego, CA	34848 Hartwell Special Products Placentia, CA
04222 AVX Corp. AVX Ceramics Div. Myrtle Beach, SC	17856 Siliconix Inc. Santa Clara, CA	37942 North American Capacitor Co. Mallory Div. Greencastle, IN
04713 Motorola Inc. Semiconductor Products Sector Phoenix, AZ	18324 Signetics Corp. Military Products Div. Orem, UT	51406 Murata Erie, No. America Inc. Symrna, GA
05791 Lyn-Tron Inc. Burbank, CA	21958 Hughes(RS)Co. Inc. Los Angeles, CA	54583 TDK Electronics Corp. Port Washington, NY
06665 Analog Devices Formerly Precision Monolithics Santa Clara, CA	22670 GM Nameplate, Inc. Seattle, WA	55566 RAF Electronic Hardware Inc. Seymour, CT
07047 Ross Milton Co., The Southampton, PA	24347 Penn Engineering Co. S. El Monte, CA	56289 Sprague Electric Co. Nashua, NH
07263 Fairchild Semiconductor North American Sales Cupertino, CA	24355 Analog Devices Inc. Norwood, MA	56708 Zilog Inc. Campbell, CA
09214 General Electric Co. Semiconductor Products Dept. Auburn, NY	26806 American Zettler Inc. Aliso Viejo, CA	59124 KOA Speer Electronics Inc. Bradford, PA
0B445 Electri-Cord Mfg. Inc. Westfield, PA	27014 National Semiconductor Corp. Santa Clara, CA	60395 Xicor Inc. Milpitas, CA
12014 Chicago Rivet & Machine Co. Naperville, IL	28213 Minnesota Mining & Mfg. Co. Consumer Specialties Div. 3M Center Saint Paul, MN	60705 Cera-Mite Corp. Grafton, WI
13103 Thermalloy Co., Inc. Dallas, TX	2M021 EFAB Mfg. Inc. Charlottesville, VA	61429 Fox Electronics Fort Myers, FL
13764 Micro Plastics Flippin, AR	30146 Symbex Corp. Painesville, OH	61935 Schurter Inc. Petaluma, CA
	30800 General Instrument Corp. Capacitor Div. Hicksville, NY	62643 United Chemi-con Inc. Rosemont, IL

supply_1.wmf

Supply Codes for Manufacturers (cont)

65940 Rohm Corp Irvine, CA	73734 Federal Screw Products Inc. Chicago, IL	89536 Fluke Corporation Everett, WA
68919 Inter-Technical Group Inc., The Wima Division Elmsford, NY	74594 Component Resources Inc. Div of EPI International Corp. Beaverton, OR	91506 Augat, Inc. Attleboro Falls, MA
71400 Bussman - Now Magnum Div. of Cooper Industries Inc. St. Louis, MO	78189 Illinois Tool Works Inc. Shakeproof Div. Elgin, IL	91637 Dale Electronics Inc. Columbus, NE
71590 CRL Components Inc. Formerly Mepco/Centralab A North American Philips Co. Fort Dodge, IA	83014 Hartwell Corp. Placentia, CA	S3385 Sanken Denki Corp. Tokoyo, Japan
71707 Coto Corp. Providence, RI	85480 W H Brady Co. Corp. Industrial Products Div Milwaukee, WI	

supply_2.wmf

USA	INTERNATIONAL			
<p>California FLW Fluke Calibration Center C/o FLW Service Corporation 3505 Cadillac Ave., Bldg E Costa Mesa, CA 92626 TEL: (714) 751-7512 FAX: (714) 755-7332</p> <p>Dallas Fluke Service Center 2104 Hutton Drive Suite 112 Carrollton, TX 75006 TEL: (214) 406-1000 FAX: (214) 247-5642</p> <p>Fluke Service Center 42711 Lawrence Place Fremont, CA 94538 TEL: (510) 651-5112 FAX: (510) 651-4962</p> <p>Illinois Fluke Service Center 1150 W. Euclid Avenue Palatine, IL 60067 TEL: (708) 705-0500 FAX: (847) 705-9989</p> <p>New Jersey Fluke Service Center W. 75 Century Rd Paramus, N.J. 07652-0930 TEL: (201) 599-9500 (599-0919) FAX: (201) 599-2093</p> <p>Washington Fluke Service Center Fluke Corporation Building #4 1420 - 75TH St. S.W. Everett WA 98203 TEL: (206) 356-5560 FAX: (206) 356-6390</p>	<p>Australia Phillips Sci. and Ind., Pty., L. 745 Springvale Road Mulgrave Victoria 3170 TEL: 61-3-881-3666 FAX: 61-3-881-3636</p> <p>Phil. Sci. & Ind. Bk F, Centrect. 34 Waterloo Road North Ryde, N.S.W. 2113 TEL: 61-2-888-8222 FAX: 61-2-888-0440</p> <p>Austria Fluke Vertriebsges. GMBH (GM) Sudrandstraße 7 P.O. Box 10, A-1232 Vienna TEL: 43-1-614-100 FAX: 43-1-614-1010</p> <p>Bahrain Mohammed Fakhroo & Bros. P.O. Box 439 Bahrain TEL: 973-253529 FAX: 973-275996</p> <p>Belgium N.V. Fluke Belgium S.A. Sales & Service Dept. Langeveldpark - Unit 5 & 7 P. Basteleusstraat 2-4-6 1600 St. Pieters - Leeuw TEL: 218-2-331-2777 (ext 218) FAX: 32-2-331-1489</p> <p>Bolivia Casilla 7295, Calle Ayacucho No. 208 Edificio Flores, 5to. Piso La Paz, Bolivia TEL: 591-2-317531 or 317173 FAX: 591-2-317545</p> <p>Brazil Philips Medical Systems, LTDA Av. Interlagos North 3493 - Campo Grande 04661-200 Sao Paulo S.P. TEL: 55-11-523-4811 FAX: 55-11-524-4873 (ID 2148)</p> <p>Sigtron Instrumentos E. Servicos Rua Alvaro Rodrigues 269 - Brooklin Sao Paulo, Sp TEL: 55-11-240-7359 FAX: 55-11-533-3749</p> <p>Sistest Sist. Instr. Testes Ltda Av. Ataulfo De Paiva 135 S/ 1117 - Lابلon 22.449-900 Rio De Janeiro, RJ, Brazil TEL: 55-21-259-5755 or 512-3679 FAX: 55-21-259-5743</p>	<p>Bulgaria Ac Sophilco, Cust. Supp. Serv. P.O. Box 42 1309 Sofia, Bulgaria TEL: 359-2-200785 FAX: 359-2-220910</p> <p>C.S.F.R. Eiso NA, Berance 2 16200 Praque 6 TEL: 42-2-316-4810 FAX: 42-2-364986</p> <p>Data Elektronik BRNO Jugoslavka 113 61300 Brno TEL: 42-5-57400-2 FAX: 42-5-574002</p> <p>Canada Fluke Electronics Canada Inc. 400 Britannia Rd East, Ut #1 Mississauga, Ontario L4Z 1X9 TEL: 905-890-7600 FAX: 905-890-6866</p> <p>Chile Intronica, Instrumen Electronica, S.A.C.I. Guardia Vieja 181 Of. 503 Casilla 16500, Santiago 9 TEL: 56-2-232-6700</p> <p>China Fluke S.C., Room 2111 Scite Tower Jianguomenwai Dajie Beijing 100004, PRC TEL: 86-10-512-6351, 6319, 3437 FAX: 86-10-512-3437</p> <p>Colombia Sistemas E Instrument., Ltda. Calle 83, No. 37-07 Po Box 29583 Santa Fe De Bogota TEL: 57-1-287-5424 FAX: 57-1-218-2660</p> <p>Costa Rica Electronic Engineering, S.A. Carretera de Circunvalacion Sabanilla Av. Novena P.O. Box 4300-1000, San Jose TEL: 506-253-3759 or 225-8793 FAX: 506-225-1286</p> <p>Croatia Kaltim - Zagreb Fluke Sis & Serv. Draga 8 41425 Sveta Jana TEL: 385-41-837115 FAX: 385-41-837237</p> <p>Denmark Fluke Danmark A/S, Cust. Supp. Ejby Industrivej 40 DK 2600 Glostrup TEL: 45-43-44-1900 or 1935 FAX: 45-43-43-9192</p>	<p>Ecuador Proteco Coasin Cia., Ltda. Av. 12 de Octubre 2449 y Orellana P.O. Box 17-03-228-A, Quito TEL: 593-2-230283 or 520005 FAX: 593-2-561980</p> <p>Egypt EEMCO Electronic Equipment Mktng Co. 9 Hassan Mazher St. P.O. Box 2009 St. Heliopolis 11361 Cairo, Egypt TEL: 20-2-417-8296 FAX: 20-2-417-8296</p> <p>Fed. Rep. of Germany Fluke Deutschland GmbH Customer Support Services Servicestützpunkt VFNS Oskar-Messter-Strasse 18 85737 Ismaning/Munich TEL: 49-89-9961-1260 FAX: 49-89-9961-1270</p> <p>Fluke Deutschland (CSS), Servicestützpunkt VFNS Meiendorfer Strasse 205 22145 Hamburg TEL: 49-40-679-6434 FAX: 49-40-679-7653</p> <p>Finland Fluke Finland Oy Sinikalliontie 3, P.L. 151 SF 02631 Espoo TEL: 358-0-6152-5600 FAX: 358-0-6152-5630</p> <p>France Fluke France S.A. 37 Rue Voltaire BP 112, 93700 Drancy, Cedex TEL: 33-1-4896-6300 FAX: 33-1-4896-6330</p> <p>Greece Philips S.A. Hellenique Fluke Sales & Service Manager 15, 25th March Street, P.O. Box 3153, 177 78 Tavros Athens TEL: 30-1-489-4911 or 4262 FAX: 30-1-481-8594</p> <p>Hong Kong Schmidt & Co, Ltd. 1st Floor 323 Jaffe Road Wanchai TEL: 852-9223-5623 FAX: 852-834-1848</p> <p>Hungary MTA MMSZ KFT, Srv. / Gen. Mgr Etele Ut. 59 - 61 P.O. Box 58 H 1502 Budapest TEL: 361-186-9589 or 209-3444 FAX: 361-161-1021</p>	<p>Iceland Taeknival HF P.O. Box 8294, Skeifunni 17 128 Reykjavik TEL: 354-1-681665 FAX: 354-1-680664</p> <p>India Hinditron Services Pvt. Inc. 33/44A 8th Main Road Raj Mahal Vilas Extension Bangalore 560 080 TEL: 91-80-334-8266 or 0068 FAX: 91-33-247-6844</p> <p>Hinditron Services Pvt. Ltd Hinditron House, 23-B Mahal Industrial Estate Mahakali Caves Rd, Andheri East Bombay 400 093 TEL: 91-22-836-4560, 6590 FAX: 91-22-836-4682</p> <p>Hinditron Services Pvt. Ltd Castle House, 5th Floor 5/1 A, Hungerford Street Calcutta 700 017 TEL: 91-33-400-194 FAX: 91-33-247-6844</p> <p>Hinditron Services Pvt. Ltd 204-206 Hemkunt Tower 98 Nehru Place New Delhi 110 019 TEL: 91-11-641-3675 or 643-0519 FAX: 91-11-642-9118</p> <p>Hinditron Services Pvt. Ltd. Field Service Center Emerald House, 5th Floor 114 Sarojini Devi Road Secunderabad 500 003 TEL: 91 40-844033 or 843753 FAX: 91-40-847585</p> <p>Indonesia P. T. Daeng Bro, Philips House J/n H.R. Rasuna Said Kav. 3-4 Jakarta 12950 TEL: 62-21-520-1122 FAX: 62-21-520-5189 or 62-21-520-5189</p> <p>Israel R.D.T Equipment & Sys, Ltd P.O. Box 58072 Tel-Aviv 61580 TEL: 972-3-645-0745 FAX: 972-3-647-8908</p> <p>Italy Fluke Italia S.R.L., CSS Viale Delle Industrie, 11 20090 Vimodrone (MI) TEL: 39-2-268-434-203 or 4341 FAX: 39-2-250-1645</p>

Figure 7-4. Service Centers

<p>Japan Fluke Corp., Sumitomo Higashi Shinbashi Bldg. 1-1-11 Hamamatsucho Minato-ku, Tokyo 105 TEL: 81-3-3434-0188 or 0181 FAX: 81-3-3434-0170</p>	<p>Nigeria Philips Projects Centre Resident Delegate / PMB 80065 8, Kofo Abayomi Street Victoria Island, Nigeria TEL: 234-1-262-0632 FAX: 234-1-262-0631</p>	<p>Singapore Fluke Singapore Pte., Ltd. Fluke ASEAN Regional Office #27-03 PSA Building 460 Alexandra Road Singapore 119963 TEL: 65-276-5161 FAX: 65-276-5929</p>	<p>United Kingdom Fluke U.K. LTD. (CSS) Colonial Way Watford, Hertfordshire WD2 4TT TEL: 44-923-240511 FAX: 44-923-225067</p>
<p>Kenya Walterfang P.O. Box 14897 Nairobi, Kenya TEL: 254-2 FAX: 254-2</p>	<p>Norway Fluke Norway A/S, Cust. Support P.O. Box 6054 Etterstad N-0601 Oslo TEL: 47-22-653400 FAX: 47-22-653407</p>	<p>South Africa Spescom Measure. (PTY) Ltd. Spescom Park Cm. Alexandra Rd. & Second St. Halfway House, Midrand 1685 TEL: 27-11-315-0757 FAX: 27-11-805-1192</p>	<p>Uruguay Coasin Instrumentos S.A. Casilla de Correo 1400 Libertad 2529, Montevideo TEL: 598-2-492-436, 659 FAX: 598-2-492-659</p>
<p>Korea B&P International Co., Ltd. Geopung Town A-303 203-1 Nonhyun-Dong Kangnam-Ku Seoul 135-010 TEL: 82 12 546-1457 FAX: 82 12 546-1458</p>	<p>Pakistan (Philips) Philips Elec. Ind. of Prof. Sys. Div. Islamic Cham. of Commerce St-2/A, Block 9, KDA Scheme 5, Clifton, Karachi-75600 TEL: 92-21-587-4641 or 4649 FAX: 92-21-577-0348</p>	<p>Spain Fluke Iberica S.L. Centro Empresarial Euronora c/Ronda de Poniente, 8 28760-Tres Cantos Madrid, Spain TEL: 34-1-804-2301 FAX: 34-1-804-2496</p>	<p>Venezuela Coasin C.A. Calle 9 Con Calle 4, Edif. Edinurbi Piso-3 La Urbina Caracas 1070-A, Venezuela TEL: 58-2-241-6214 FAX: 58-2-241-1939</p>
<p>IL MYOUNG, INC. Youngdong P.O. Box 1485 780-46, Yeogsam-Dong Kangnam-Ku, Seoul TEL: 82 2 552-8582-4 FAX: 82 2 553-0388</p>	<p>Peru Impor. & Repres. Electronicas S.A., J.R. Pumacahua 955 Lima 11 TEL: 51-14-23-5099 FAX: 51-14-31-0707</p>	<p>Sweden Fluke Sverige AB, (CSS) P.O. Box 61 S-164 94 Kista TEL: 46-8-751-0235 or 0230 FAX: 46-8-751-0480</p>	<p>Vietnam Schmidt-Vietnam Co., Ltd. 8/FI. Schmidt Tower Hanoi International Tech. Ctr KM8, Highway 32, Cau Giay Tu Liem, Hanoi Vietnam TEL: 84-4-346186 or 346187 FAX: 84-4-346-188</p>
<p>Kuwait Yusuf A. Alghanim & Sons W.L.L. P.O. Box 223 Safat Alghanim Industries Airport Road Shuwaikh 13003 Kuwait TEL: 965-4842988 FAX: 965-4847244</p>	<p>Philippines Spark Electronics Corp. P.O. Box 610, Greenhills Metro Manila 1502 TEL: 63-2-700-621 FAX: 63-2-721-0491 or 700-709</p>	<p>Switzerland Fluke Switzerland AG, (CSS) Rutistrasse 28 CH 8952 Schlieren Switzerland TEL: 41-1-730-3310 or 730-3932 FAX: 41-1-730-3932</p>	<p>West Indies Western Scientific Co., Ltd. Freeport Mission Road Freeport, Trinidad West Indies TEL: 809-673-0038 FAX: 809-673-0767</p>
<p>Malaysia CNN. SDN. BHD. 17D, 2nd Floor Labuhraya Batu Lancang Taman Seri Damai 11600 Jelutong Penang TEL: 60-4-657-9584 FAX: 60-4-657-0835</p>	<p>Poland Elec. Instr. Srv. Philips Cons. UL. Malechowska 6 60 188 Poznan TEL: 48-61-681998 FAX: 48-61-682256</p>	<p>Taiwan Schmidt Scientific Taiwan, Ltd. 6th Floor, No. 109, Tung Hsing Street Taipei, Taiwan R.O.C. TEL: 886-2-767-8890 or 746- 2720 FAX: 886-2-767-8820</p>	<p>Yugoslavia Jugoekonom Beograd T & M Customer Support Services Knez Mihailova 33 11070 Novi TEL: 38-11-182470 FAX: 38-11-638209</p>
<p>Mexico Metro. Y Calibraciones Ind., S.A. Diagonal No. 17 - 3 Piso Col. Del Valle C.P. 03100, Mexico D.F. TEL: 52-5-682-8040 FAX: 52-5-687-8695</p>	<p>Portugal Fluke Iberica S.L. Sasles Y Services Dept Campo Grande 35 - 7b 1700 Lisboa TEL: 351-1-795-1712 FAX: 351-1-795-1713</p>	<p>Thailand Measuretronix Ltd. 2102/31 Ramkamhang Road Bangkok 10240 TEL: 66-2-375-2733 or 2734 FAX: 66-2-374-9965</p>	<p>Zimbabwe Field Technical Sales 45, Kelvin Road North P.O. Box Cy535 Causeway Harare, Zimbabwe TEL: 263-4-750381 or 750382 FAX: 263-4-729970</p>
<p>Netherlands Fluke Nederland B.V. (CSS) Afdeling Service Science Park Eindhoven 5108 5692 EC Son TEL: 31-40-2678 FAX: 31-40-2678</p>	<p>Romania Ronex S.R.L., Cust. Supp. Serv. Str. Transilvaniei Nr. 24 70778 Bucharest - I TEL: 40-1-614-3597 or 3598 FAX: 40-1-659-4468</p>	<p>Turkey Pestas Prof. Elektr. Sist. Tic. V Selcuklar Caddesi Meydan Apt. No. 49, Daire 23 Akatlar 80630 Istanbul TEL: 90-212-282-7838 FAX: 90-212-282-7839</p>	
<p>New Zealand Philips Scientific & Ind., Pty., L. Private Bag 41904, St. Lukes, 2 Wagener Place Mt. Albert, Auckland 3 TEL: 64-9-894-4160 FAX: 64-9-849-7814</p>	<p>Russia Infomedia UL. Petrovsko Razumovsky Proezd. 29 103287 Moscow TEL: 7-95-212-3833 FAX: 7-95-212-3838</p>	<p>U.A.E. Haris Al Afaq Ltd. P.O. Box 8141 Dubai TEL: 971-4-283623 or 283624 FAX: 971-4-281285</p>	
	<p>Saudi Arabia A. Rajab & Sisilah Co. S&S Dept. P.O. Box 203 21411 Jeddah TEL: 966-2-661-0006 FAX: 966-2-661-0558</p>		

Figure 7-4. Service Centers (cont)

Chapter 8

Options and Accessories

	Title	Page
8-1.	INTRODUCTION.....	8-3
8-2.	ACCESSORIES	8-4
8-3.	Rack-Mount Kits (Y8834, Y8835 and Y8836).....	8-4
8-4.	Shielded IEEE-488 Interface Cables (Y8021, Y8022, and Y8023)...	8-4
8-5.	Replacement Test Leads (TL70A)	8-4
8-6.	Deluxe Test Lead Kits (Y8134)	8-4
8-7.	Slim-Flex Test Leads (Y8140).....	8-4
8-8.	Temperature Probes (80T-150U, and 80TK.)	8-4
8-9.	RF Probes (85RF and 83RF).....	8-4
8-10.	Current Shunt (80J-10).....	8-5
8-11.	Current Probes (Y8100, Y8101, 80i-400 and 80i-600).....	8-5
8-12.	High Voltage Probes (80K-6 and 80K-40)	8-5

8-1. INTRODUCTION

A number of options and accessories are available which can enhance the 8842A's capabilities and increase operator safety. The accessories are summarized in Table 8-1 and described in the following paragraphs. The options are summarized in Table 8-2 and described in the following subsections.

Table 8-1. Accessories

MODEL	DESCRIPTION
Y8021	IEEE-488 Interface Cable (1m)
Y8022	IEEE-488 Interface Cable (2m)
Y8023	IEEE-488 Interface Cable (4m)
Y8834	Single Rack-Mount Kit
Y8835	Dual Rack-Mount Kit
Y8836	Center Rack-Mount Kit
TL70A	Replacement Test Leads
Y8134	Replacement Test Leads
Y8140	Slim-Flex Test Leads
80T-150U	Temperature Probe
80TK	K-Type Thermocouple Converter
85RF	RF Probe (100 kHz to 500 MHz)
83RF	RF Probe (100 kHz to 100 MHz)
80J-10	Current Shunt
Y8100	Current Probe (200A ac/dc)
Y8101	Current Probe (150A ac)
80I-400	Current Probe (400A ac)
80I-600	Current Probe (600A)
80K-6	High Voltage Probe (6,000V)
80K-40	High Voltage Probe (40,000V)

Table 8-2. Options

NUMBER	OPTION
-05	IEEE-488 Interface
-09	True RMS AC

8-2. ACCESSORIES

Accessories include a variety of rack-mounting kits, cables, test leads, and probes. The accessories include installation and/or operating instructions.

8-3. *Rack-Mount Kits (Y8834, Y8835 and Y8836)*

The rack-mount kits allow the 8842A to be mounted in standard 19-inch rack panels. The Y8834 kit allows the 8842A to be mounted either on the left or the right. The Y8835 kit allows two 8842As to be mounted side-by-side. The Y8836 kit allows the 8842A to be mounted in the center of the rack. Installation instructions are given in Section 2, and are also included with each kit.

8-4. *Shielded IEEE-488 Interface Cables (Y8021, Y8022, and Y8023)*

Shielded IEEE-488 cables are available in three lengths (see Table 8-1). The cables attach the 8842A to any other IEEE-488 device. Each cable has double 24-pin connectors at both ends to allow stacking. Metric threaded mounting screws are provided with each connector.

8-5. *Replacement Test Leads (TL70A)*

The TL70A replacement test leads feature safety-designed input connectors.

8-6. *Deluxe Test Lead Kits (Y8134)*

Each deluxe test lead kit includes two test-tip probes, two alligator clips, two large spade lug tips, and one spring-loaded hook tip and probe.

8-7. *Slim-Flex Test Leads (Y8140)*

The Y8140 has adjustable, flexible, and insulated leads, and can fit into small places. The sharp steel needle points will pierce varnish and thin insulation.

8-8. *Temperature Probes (80T-150U, and 80TK.)*

The 80T-150U is a universal temperature probe designed to provide virtually any DMM with temperature measurement capability. The probe provides direct temperature conversion of 1 mV dc per degree. A three-position switch acts as a power switch and is used for selecting Celsius or Fahrenheit scaling for the output. The 80TK thermocouple module converts the microvolt output from a "K" type thermocouple to a 1 mV per degree signal. The on-off switch allows selection of degrees "C" or "F" output scaling.

8-9. *RF Probes (85RF and 83RF)*

The RF probes (85RF and 83RF) use the DMM dc volts function to measure radio frequency (RF) ac signals. The 83RF has a frequency range of 100 kHz to 100 MHz; the 85RF has a frequency range of 100 kHz to 500 MHz. The probes are calibrated so that the dc output is equivalent to the rms value of a sine wave input over a range of 0.25V to 30V rms.

For best accuracy, the probes should be used with DMMs having 10 M Ω input impedance. This condition is satisfied by the 8842A in the 200V and 1000V ranges. The probes can also be used with the 8842A in the 200 mV, 2V, and 20V ranges if a 10 M Ω resistor is connected in parallel across the 8842A input terminals.

8-10. Current Shunt (80J-10)

The 80J-10 current shunt extends ac or dc current measurement up to 10A continuous, or to 20A for one minute without overheating.

8-11. Current Probes (Y8100, Y8101, 80i-400 and 80i-600)

The current probes extend the ac and dc current measurement range. The Y8100 current probe uses the Hall effect to measure dc or ac current up to 200A (in two ranges) without electrical contact. The Y8101 is a low-cost, compact current probe which uses a transformer to measure ac current from 2A to 150A. The 80i-600 uses a transformer to measure ac current from 1A to 600A, and features a large jaw opening for industrial use. The Y8101, 80i-400 and 80i-600 measure ac current only.

8-12. High Voltage Probes (80K-6 and 80K-40)

The high voltage probes extend the dc and ac voltage measurement range while minimizing shock hazard. The 80K-6 has a range of 0 to 6000V dc or peak ac, with frequency response to 1 kHz; the 80K-40 has a range of 0 to 40,000V dc or peak ac, with frequency response to 60 Hz. As the probes use 1000:1 dividers, the probes have a high input impedance and cause minimal circuit loading. The probes are impedance matched for both ac and dc measurements. A plastic body protects the operator from the voltage being measured.

For best accuracy, the probes should be used with DMMs having 10 M Ω input impedance. This condition is satisfied by the 8842A in the 200V dc and 1000V dc ranges. The probes can also be used with the 8842A in the 200 mV dc, 2V dc, and 20V dc ranges if a 10 M Ω resistor is connected in parallel across the input terminals.

Chapter 805
Option –05 IEEE-488 Interface

Title	Page
805-1. INTRODUCTION.....	805-3
805-2. CAPABILITIES.....	805-3
805-3. EXTERNAL CONTROLS.....	805-3
805-4. INSTALLATION.....	805-3
805-5. PROGRAMMING INSTRUCTIONS.....	805-4
805-6. MAINTENANCE.....	805-4
805-7. LIST OF REPLACEABLE PARTS.....	805-4

805-1. INTRODUCTION

The IEEE-488 Interface turns the 8842A into a fully programmable instrument for use with the IEEE Standard 488-1978 interface bus (IEEE-488 bus). With the IEEE-488 Interface, the 8842A can become part of an automated instrumentation system. The 8842A can be under complete, interactive control from a remote bus controller, or it can be set to the talk-only mode, connected to a data logger or printer, and dedicated to a single task.

805-2. CAPABILITIES

The IEEE-488 Interface provides remote control of all front panel controls except for the POWER, CAL ENABLE, and FRONT/REAR switches. Other features include:

- A simple and predictable command set
- Fast measurement throughput
- Full talk/listen capability, including talk-only operation
- Full serial poll capability, with bit-maskable SRQ
- Full remote/local capability, including local lockout
- External Trigger and Sample Complete connectors
- Remote calibration
- Programmable trigger sources, including two bus triggers
- Informative output suffix (suppressible)
- Selectable output terminators

The 8842A supports the following interface function subsets: SH1, AH1, T5, L4, SR1, RL1, DC1, DT1, E1, PP0, and C0.

805-3. EXTERNAL CONTROLS

When the IEEE-488 Interface is installed, the rear panel contains EXT TRIG (External Trigger) and SAMPLE COMPLETE connectors. These controls can be used even when the 8842A is disconnected from the IEEE-488 bus. Refer to Section 2 for details.

805-4. INSTALLATION

The IEEE-488 Interface is contained on a single, easy-to-install printed circuit assembly (PCA). To install the option, proceed as follows:

WARNING

TO AVOID ELECTRIC SHOCK, DISCONNECT THE POWER CORD AND ANY INPUT LEADS BEFORE REMOVING THE INSTRUMENT CASE.

1. Remove the grounding screw from the bottom of the case and remove the two rear panel mounting screws (Figure 805-1A).
2. Holding the front panel, slide the case and rear bezel off of the chassis (Figure 805-1B). Note: At this point, the rear bezel is not secured to the case.

3. Disconnect the ribbon cable from the plastic rear panel insert by pulling the tabs on either side of the ribbon cable connector outward. Pull the ribbon cable directly toward the front panel (Figure 805-1C).
4. Remove the rear panel insert by releasing the two snap tabs inside the instrument (Figure 805-1D).

NOTE

The connection on the rear panel insert is used for factory calibration only. The connector is electrically isolated from all measuring circuitry.

5. Connect the the ribbon cable from the Main PCA to the connector on the IEEE-488 Interface PCA (Figure 805-1E).
6. Latch the ribbon cable in place as shown in Figure 805-1F.
7. Make sure the heads of the plastic latches are in the extended position.
8. With the component side down, guide the BNC and IEEE-488 connectors (located on the rear of the IEEE-488 Interface PCA) into the rear panel, and seat the IEEE-488 Interface PCA on the mounting supports on the chassis (Figure 805-1G).
9. Fasten the IEEE-488 Interface PCA to the chassis by pressing the two plastic latches into the mounting supports. (See Figure 805-1H.)
10. Secure the IEEE-488 connector to the rear panel with the two screws and washers supplied.
11. Replace the cover and rear bezel on the chassis and attach the two ear panel mounting screws.
12. Attach the grounding screw to the bottom of the case.

WARNING

TO AVOID ELECTRIC SHOCK, ENSURE THE GROUNDING SCREW IS FIRMLY ATTACHED TO THE CASE BOTTOM.

805-5. PROGRAMMING INSTRUCTIONS

Programming instructions are presented in Section 3. That section also explains how to set up the 8842A on the IEEE-488 bus.

805-6. MAINTENANCE

All service information regarding Option -05 is contained in Section 6. The theory of operation is contained in Section 5.

805-7. LIST OF REPLACEABLE PARTS

A list of replaceable parts for the IEEE-488 Interface printed circuit assembly (PCA) is given in Table 805-1. Refer to Section 7 for ordering information.

Caution

The symbol ⚡ indicates a device that may be damaged by static discharge.

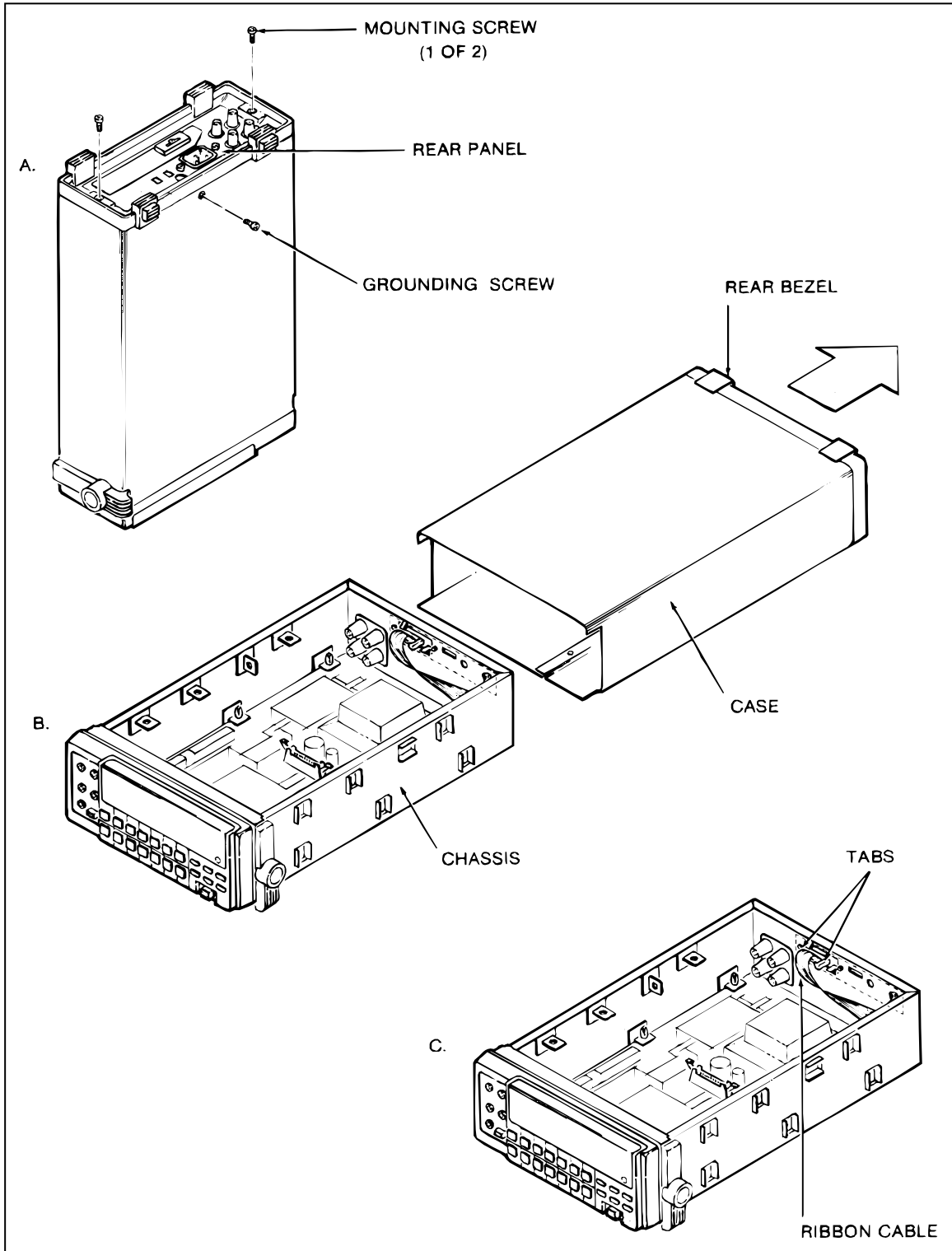
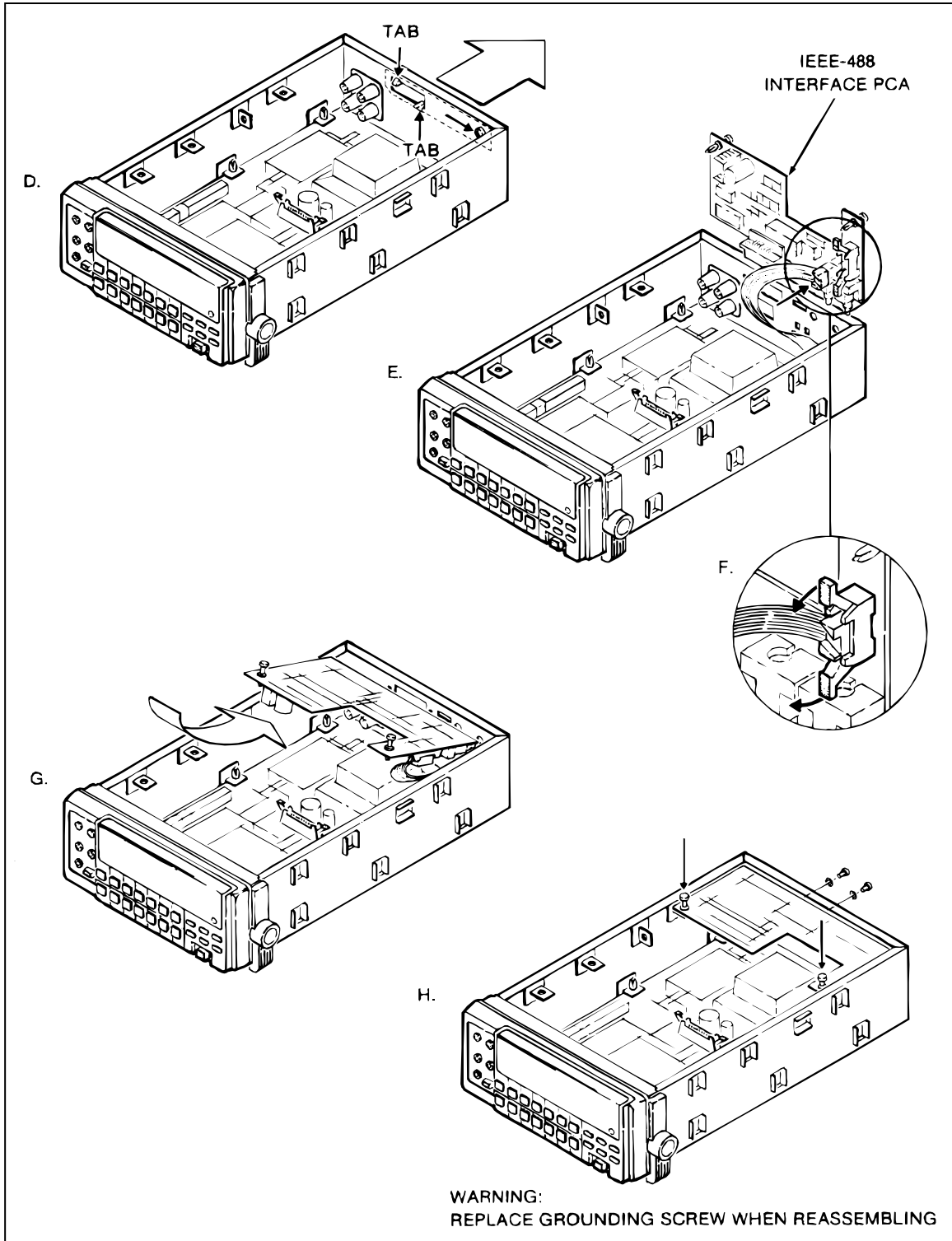

Figure 805-1. Installing Option -05

f805-1_1.wmf



f805-1_2.wmf

Figure 805-1. Installing Option -05 (cont)

Table 805-1. Option -05A IEEE-488 Interface PCA

REFERENCE DESIGNATOR	DESCRIPTION	FLUKE STOCK NO	MFRS SPLY CODE	MANUFACTURERS PART NUMBER OR GENERIC TYPE	TOT QTY	NOTES
C 901	CAP, TA, 1UF, +-20%, 35V	697417	56289	199D105X0035AG2	1	
C 902, 903, 907, C 908	CAP, CER, 0.01UF, +80-20%, 50V, 25V	697284	60705	562CZ5USE50EE103M	4	
C 909	CAP, CER, 430PF, +-5%, 50V, C0G	697284				
C 910	CAP, AL, 4700UF, +30-10%, 16V, SOLV PROOF	732644	04222	SR595A431JAA	1	
C 911, 918-920, C 923, 925-928	CAP, CER, 0.22UF, +60-20%, 50V, 25V	460261	62643	KME16VN472K23X27LLV	1	
C 914	CAP, CER, 1000PF, +-20%, 50V, X7R	733386	04222	SR595E224ZAA	9	
C 915	CAP, TA, 47UF, +-20%, 10V	733386				
C 921, 922	CAP, CER, 15PF, +-20%, 50V, C0G	697458	04222	SR595C102MAA	1	
CR 901, 902	ZENER, UNCOMP, 3.9V, 10%, 20.0MA, 0.4W	733246	56289	199D476X0010DG2	1	
CR 903-906, 910	DIODE, SI, BV= 75.0V, IO=150MA, 500MW	697524	04222	SR595A150MAA	2	
CR 908, 909	DIODE, SI, 100 PIV, 1.0 AMP	113316	81349	1N748	2	
E 902	RES JUMPER, 0.02, 0.25W	203323	65940	1N4448	5	
H 4	NUT, HEX, STL, 4-40	742874	65940	1N4002A	2	
H 5	SCREW, PH, P, SEMS, STL, 4-40, .250	697060	59124	Z-25	1	
H 6, 7	FASTENER, GROMMET, POLYCARB, .271	110635	COMMER	CIAL	1	
H 8, 9	FASTENER, PLUNGER, NYL, .271	185918	COMMER	CIAL	1	
J 901	CONN, MICRO-RIBBON, REC, PWB, RTANG, 24 POS	682898	34848	HN4G-44-1	2	
J 902	HEADER, 2 ROW, .100CTR, 10 PIN	682906	83014	HN4P-44-4-1	2	
J 903, 904	CONN, COAX, BNC (F), PWB, RT ANG	911508	00779	554923-2	1	
MP 2	HEAT DIS, VERT, 1.18X1.00X0.50, TO-220	697359	28213	3446-6322	1	
R 911, 912	RES, CF, 33K, +-5%, 0.25W	911487	89536	911487	2	
R 913, 914	RES, CF, 1.5K, +-5%, 0.25W	414128	13103	60306-TT	1	
R 915, 916, 919	RES, CF, 470, +-5%, 0.25W	348888	81349	RCR07G333JS	2	
R 917, 918, 938	RES, CF, 100, +-5%, 0.25W	343418	81349	RCR07G152JS	2	
R 943	RES, CF, 68K, +-5%, 0.25W	343434	81349	RCR07G471JS	3	
R 944	RES, CF, 51K, +-5%, 0.25W	348771	81349	RCR07G101JS	3	
R 945-947	RES, CF, 10K, +-5%, 0.25W	376652	81349	RCR07G683JS	1	
RV 901	FILTER, EMI, 12VDC, 7A, HV SURGES	376434	81349	RCR07G513JS	1	
S 901	SWITCH, DIP, SPST, PIANO, SEALED, 8 POS	348839	81349	RCR07G102JS	3	
TP 901-903, 905, TP 906	TERM, FASTON, TAB, .110, SOLDER	807545	51406	DSS71091D223S12-22M	1	
U 901	IC, CMOS 28, RK OTP, R840A-39271	658567	00779	1-435802-5	1	
U 905	IC, LSTTL, HEX INVERTER W/3-STATE OUT	512889	00779	62395-1	5	
U 908	IC, COMPARATOR, QUAD, 14 PIN DIP	879270	89536	R79270	1	
U 909	IC, LSTTL, HEX INVERTER W/SCHMT TRIG	654442	01295	SN74LS368AN	1	
U 910	IC, LSTTL, QUAD 2 INPUT OR GATE	387233	04713	LM339N	1	
U 911	IC, NMOS, GPIB TALKER/LISTENER/CNTRLR	483180	01295	SN74LS14N	1	
U 912	IC, LSTTL, OCTAL GPIB ACTV PULL-UP XCVR	395108	01295	SN74LS32N	1	
U 913	IC, LSTTL, OCTAL GPIB XCVR W/OPEN COL	775145	33297	UPD7210 (C OR D)	1	
VR 901	IC, VOLT REG, FIXED, +5 VOLTS, 1.5 AMPS	585232	01295	SN75161BN	1	
X 901	SOCKET, IC, 40 PIN, DUAL WIPE, RETENTION	585224	01295	SN75160BN	1	
Y 901	CRYSTAL, 8.00MHZ QUARTZ HC-18U	428847	04713	MC7805T	1	
Z 903	RES, CERM, DIP, 14 PIN, 13 RES, 3.3K, +-5%	756668	00779	2-641616-1	1	
		707133	61429	FOX HC-18U-8:00	1	
		735402	91657	MDP14-01-332J	1	
NOTES:	† Static sensitive part.					

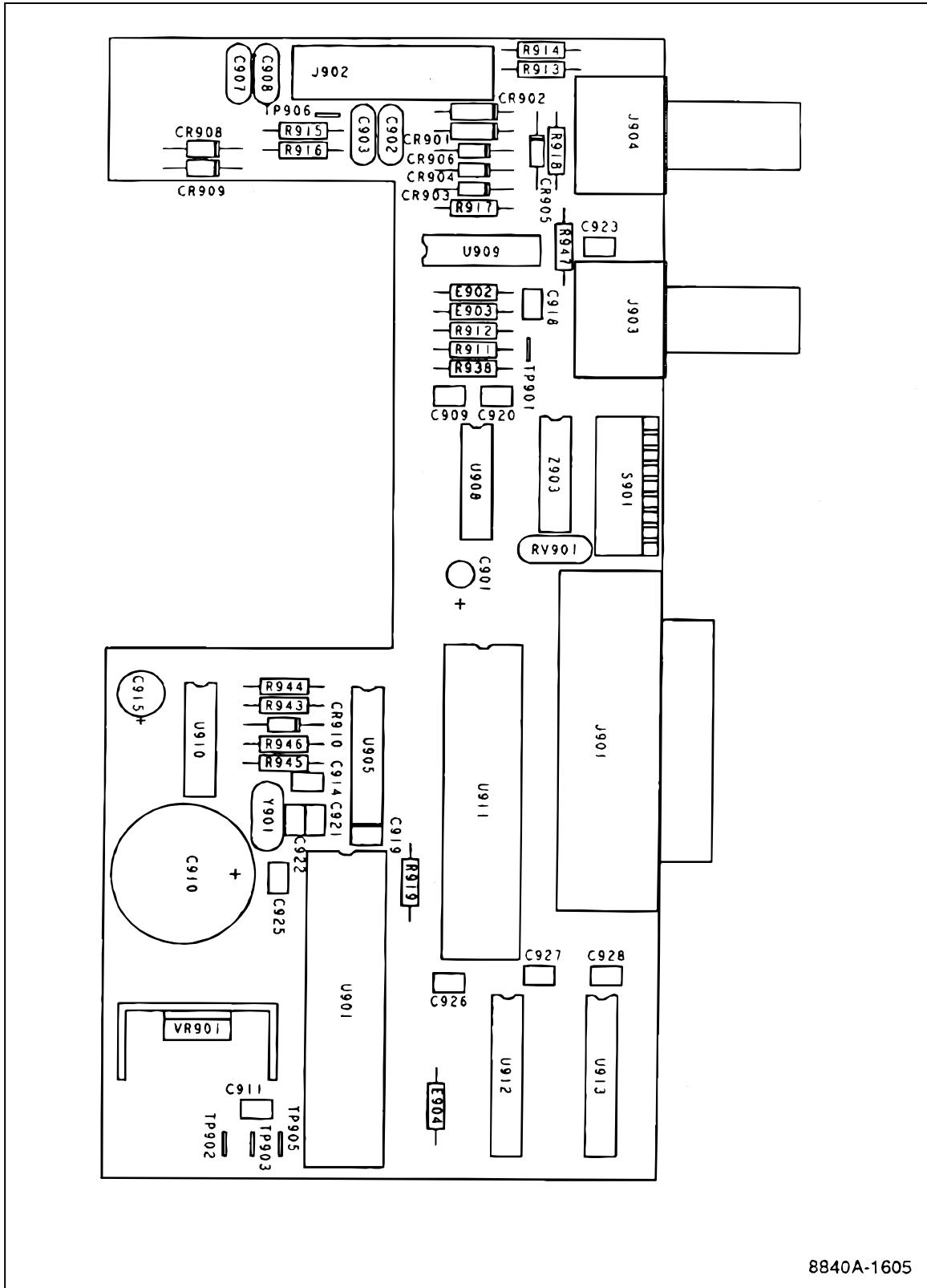

8840A-1605

f805-2.wmf

Figure 805-2. IEEE-488 Interface PCA

Chapter 809
Option –09 True RMS AC

Title	Page
809-1. INTRODUCTION.....	809-3
809-2. INSTALLATION.....	809-3
809-3. OPERATING INSTRUCTIONS.....	809-4
809-4. MAINTENANCE.....	809-4
809-5. LIST OF REPLACEABLE PARTS.....	809-4

809-1. INTRODUCTION

The True RMS AC option gives the 8842A the ability to make ac voltage and current measurements. The ac functions are selected with the front panel VAC and mA AC buttons, or by remote commands if the IEEE-488 Interface option is installed. Specifications for Option -09 are shown in Section 1, Table 1-1.

809-2. INSTALLATION

The True RMS AC option is contained on a single, easy-to-install printed circuited assembly (PCA). To install the option, proceed as follows:

WARNING

TO AVOID ELECTRIC SHOCK, DISCONNECT THE POWER CORD AND TEST LEADS BEFORE REMOVING THE INSTRUMENT CASE.

1. Remove the grounding screw from the bottom of the case and remove the two rear panel mounting screws (Figure 809-1A).
2. Holding the front panel, slide the case and rear bezel off of the chassis (Figure 809-1B). (At this point, the rear bezel is not secured to the case.)
3. Holding the True RMS AC PCA slightly above the chassis, component side down, connect the the ribbon cable from the True RMS AC PCA to the Main PCA and latch it in place. (See Figure 809-1C and D.)
4. Connect the red lead from the True RMS AC PCA to stud W301 on the Main PCA. (See Figure 809-1C.) The stud is located next to the forward end of the FRONT/REAR switch.
5. Make sure the heads of the four plastic latches are in the extended position. Guide the PCA into the 4 circuit board supports.
6. Fasten the True RMS AC PCA to the chassis by pressing the four nylon latches into the mounting supports on the chassis. (See Figure 809-1E.)
7. Reinstall the cover and rear bezel on the chassis and attach the two rear panel mounting screws.
8. Attach the grounding screw to the bottom of the case.

WARNING

TO AVOID ELECTRIC SHOCK, ENSURE THE GROUNDING SCREW IS FIRMLY ATTACHED TO THE CASE BOTTOM.

9. Calibrate the VAC voltage and mA AC functions according to the calibration instructions given in the Maintenance section.

809-3. OPERATING INSTRUCTIONS

For operating instructions, refer to Section 2. For ac measurement considerations, refer to Section 4.

809-4. MAINTENANCE

All service information regarding Option -09 is contained in Section 6. The theory of operation is contained in Section 5.

809-5. LIST OF REPLACEABLE PARTS

A list of replaceable parts for the True RMS AC printed circuit assembly (PCA) is given in Table 809-1. Refer to Section 7 for ordering information.

CAUTION

The symbol * indicates a device that may be damaged by static discharge.

http://www.else.sk/product.php?id_product=564

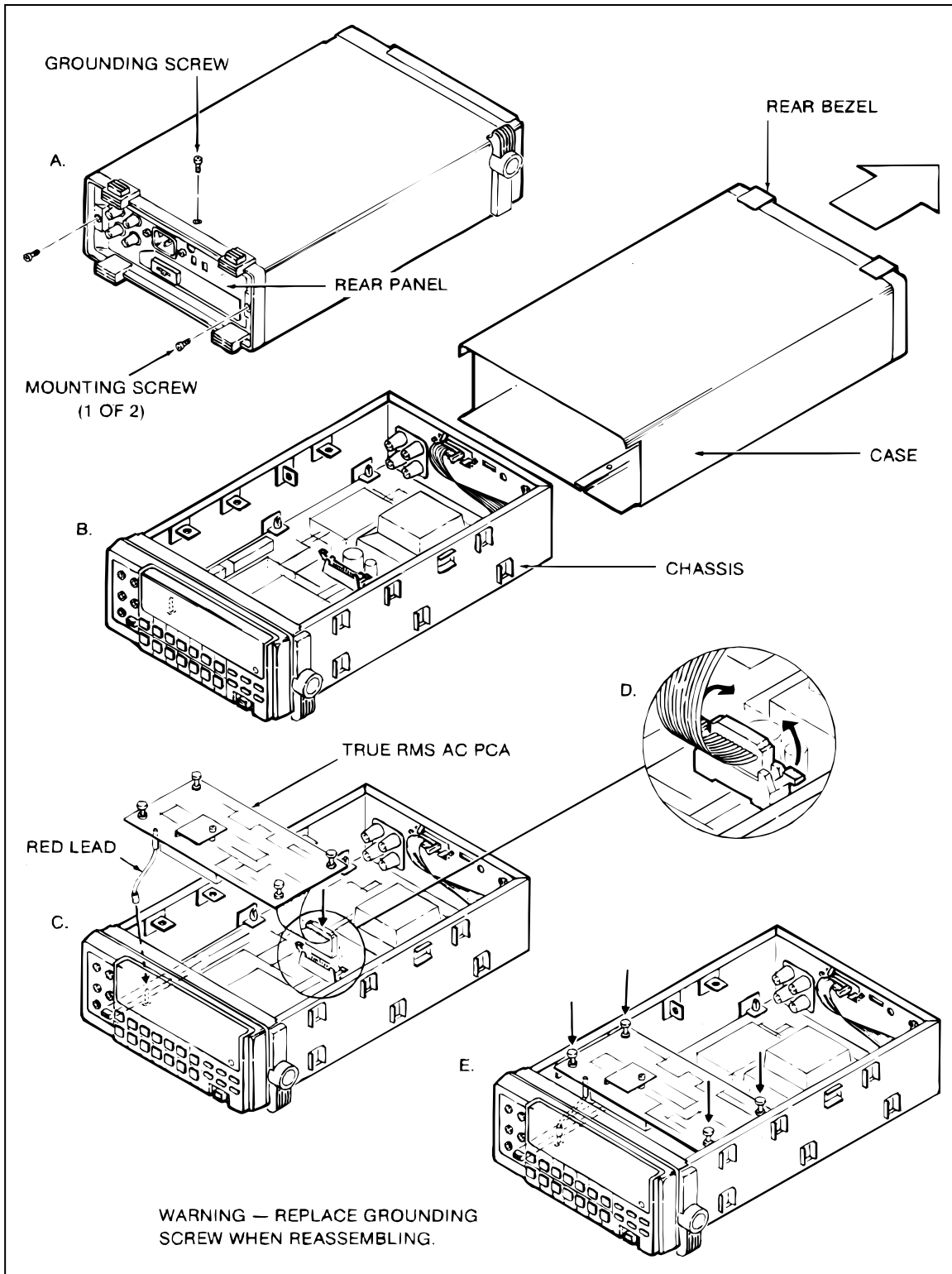

Figure 809-1. Installing Option -09

f809-1.wmf

Table 809-1. Option -09 True RMS AC PCA

Reference Designator	Description	Fluke Stock No	Tot Qty	Notes
C801	CAP,POLYES,0.068UF,+10%,1000V	714816	1	
C802	CAP,CER,56PF,+2%,50V,C0G	714378	1	
C803	CAP,CER,33PF,+2%,50V,C0G	715292	1	
C804	CAP,CER,6.8PF,+0.25PF,50V,C0G	715243	1	
C805,C806,C813	CAP,POLYES,1UF,+10%,50V	733089	3	
C807,C808,C820	CAP,POLYES,0.47UF,+10%,50V	697409	3	
C809,C810,C824	CAP,CER,0.22UF,+80-20%,50V,Z5U	733386	3	
C811,C812	CAP,TA,1UF,+20%,35V	697417	2	
C814	CAP,CER,1000PF,+20%,50V,X7R	697458	1	
C816	CAP,CER,680PF,+5%,50V,C0G	743351	1	
C819	CAP,CER,1.2PF,+0.25PF,50V,C0K	715235	1	
C821	CAP,TA,10UF,+20%,10V	714766	1	
C822,C823	CAP,TA,10UF,+20%,25V	714774	2	
C825	CAP,CER,0.01UF,+80-20%,50V,Z5V	697284	1	
C826	CAP,CER,39PF,+2%,50V,C0G	714840	1	
C827	CAP,CER,12PF,+2%,50V,C0G	715169	1	
C828	CAP,CER,68PF,+2%,50V,C0G	715300	1	
C829	CAP,CER,22PF,+2%,50V,C0G	714832	1	
CR801,CR802	* DIODE,SI,BV=20V,IO=50MA,SELECT IR	348177	2	
CR803-805	* DIODE,SI,BV=75V,IO=150MA,500MW	203323	3	
H1,H4-6	FASTENER,GROMMET,POLYCARB.,271	682898	4	
H2,H7-9	FASTENER,PLUNGER,NYL.,271	682906	4	
H3	SCREW,PH,P,THD CUT,STL,4-14,.500	853668	1	
K801	RELAY,REED,1 FORM A,5V,HIGH VOLTAGE	714352	1	
K802	RELAY,REED,1 FORM A,4.5VDC	404590	1	
MP1	SHIELD, BOTTOM	873732	1	
MP2	SHIELD, TOP	784819	1	
MP3	SPACER,SNAP,.180 RND,NYL.,125	844845	1	
Q801,Q803,Q805	* TRANSISTOR,SI,PNP,40V,0.35W,TO-92	698233	3	
Q802,Q804,Q806	* TRANS,SI,N-JFET,SEL,TO-92	707968	3	
R804,R805	RES,MF,10K,+0.1%,0.125W,25PPM	435065	2	
R806,R811	RES,MF,20K,+0.1%,0.125W,25PPM	340620	2	
R807	RES,MF,5K,+0.1%,0.125W,25PPM	340240	1	
R809	RES,CF,8.2K,+5%,0.25W	441675	1	
R810,R825-827	RES,CF,100K,+5%,0.25W	348920	4	
R812	RES,MF,2.222K,+0.1%,.125W,25PPM	706143	1	
R813	RES,CF,150K,+5%,0.25W	348938	1	
R814,R823,R836,R837	RES,CF,0.50,+5%,0.25W	830646	4	
R816,R819	RES,CF,75K,+5%,0.25W	394130	2	
R817	RES,CF,91K,+5%,0.25W	441709	1	
R822	RES,CF,2K,+5%,0.25W	441469	1	
R828	RES,CF,12K,+5%,0.25W	348847	1	
R829	RES,CF,15K,+5%,0.25W	348854	1	
R830,R831	RES,MF,10K,+0.1%,0.125W,50PPM	343459	2	
R832	RES,MF,4.99K,+1%,0.125W,100PPM	168252	1	
R833,R834	RES,CF,10,+5%,0.25W	340075	2	
R835	RES,CF,100K,+5%,0.25W	658963	1	
TP801-811	TERM,FASTON,TAB,.110,SOLDER	512889	11	
U801,U806	* IC,OP AMP,DUAL,LO-NOISE,8 PIN	707976	2	
U802	* IC,BPLR,TRUE RMS TO DC CONVERTER	741900	1	
U803	* IC,LSTTL,OCTAL D F/F,+EDG TRG	473223	1	
U804,U808	* IC,CMOS,QUAD BILATERAL SWITCH	586735	2	
U807	* IC,OP AMP,JFET INPUT,8 PIN DIP	472779	1	
U809	* IC,OP AMP,JFET IN,COMPENSTD,8 PIN DIP	418780	1	
U810	* IC,OP AMP,PRECISION,JFET INPUT	808097	1	
W3	CABLE ASSY,FLAT,20 CONDUCT,4.5	714014	1	
Z801	* RNET,CERM,SIP,8840 HI V DIVIDER	704478	1	

t809-1.wmf

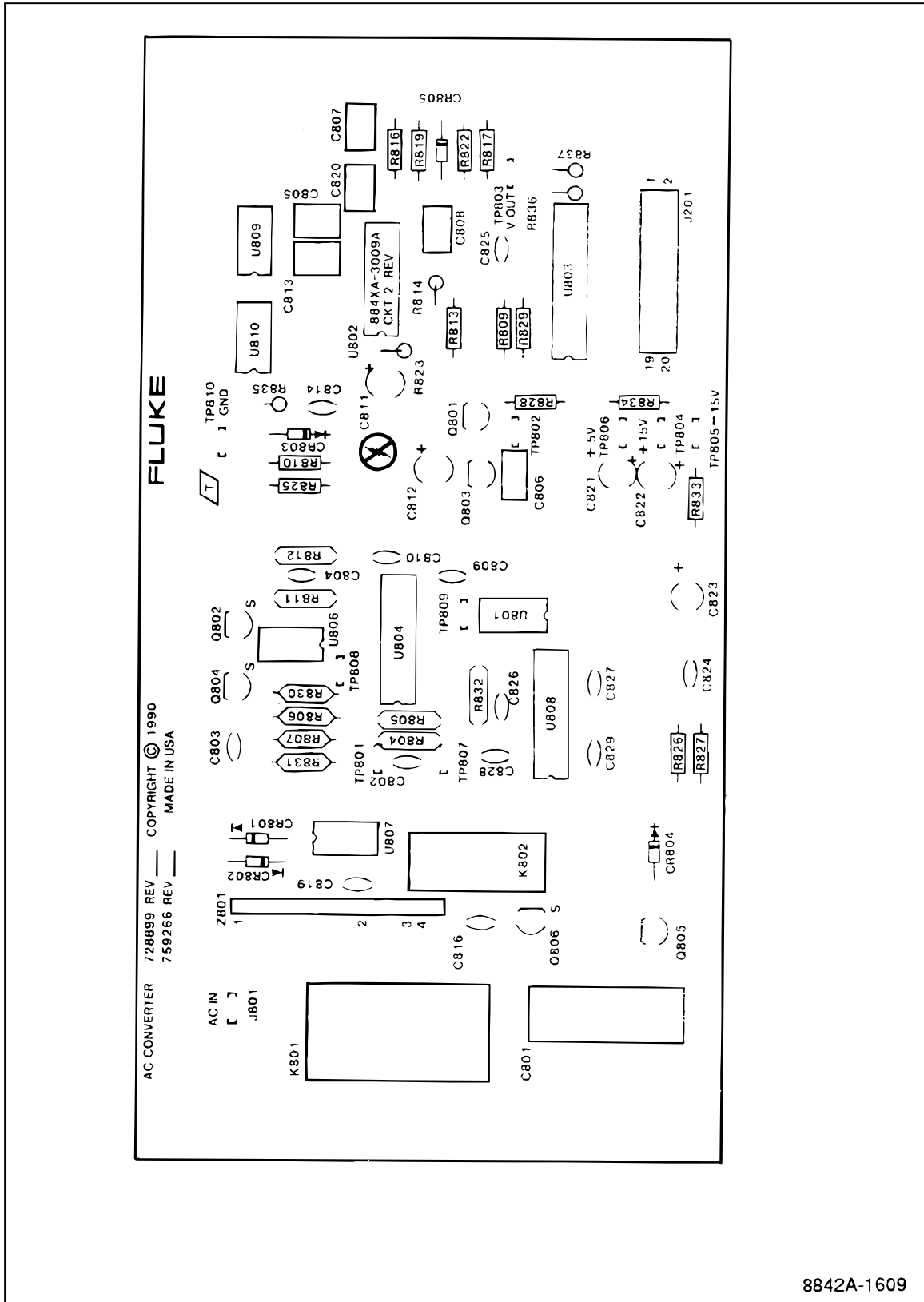
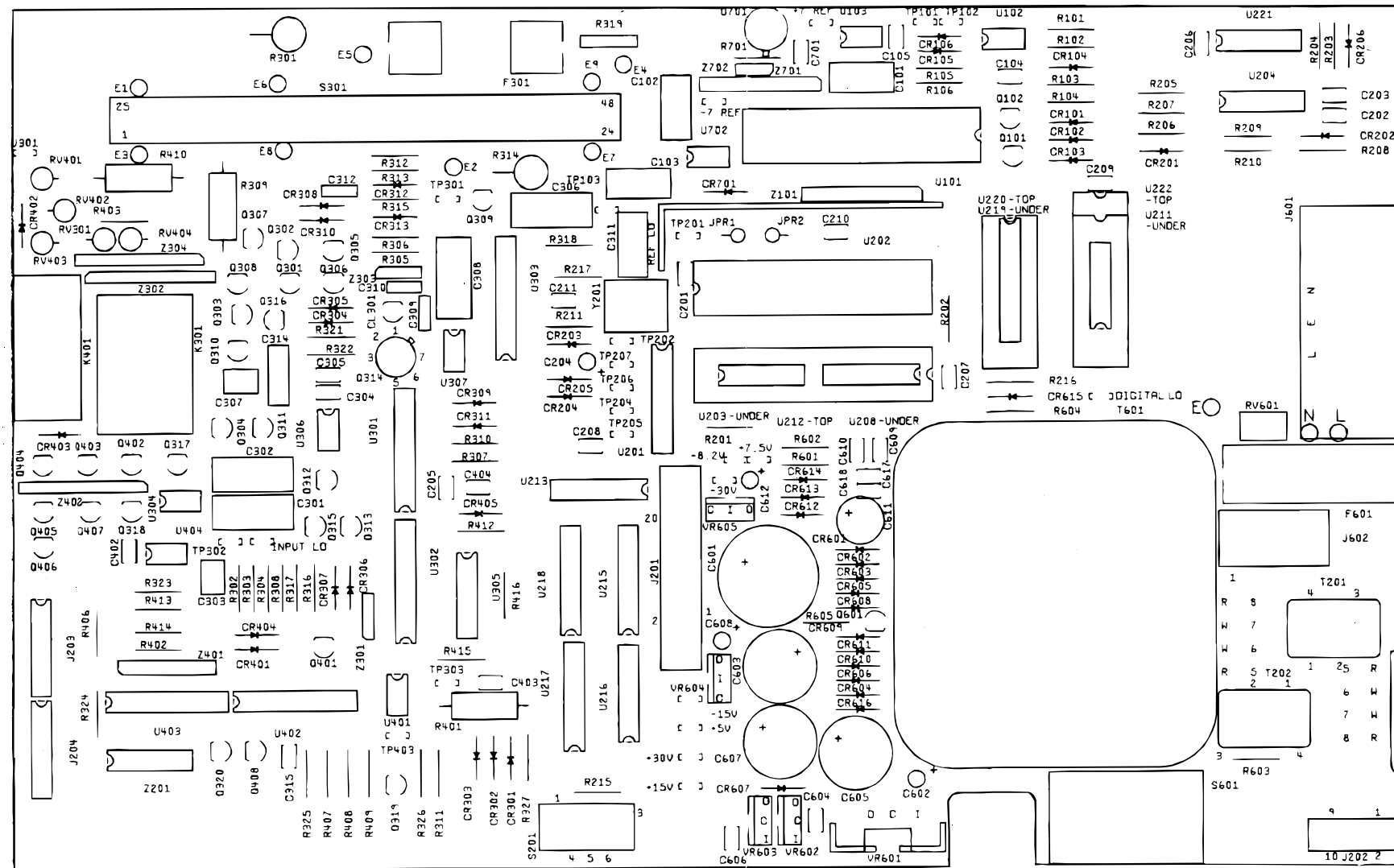

Figure 809-2. True RMS AC PCA

Chapter 9
Schematic Diagrams



8842A-1601

f9-01_1.wmf

Figure 9-1. Main PCA, DC Scaling and F/R Switch

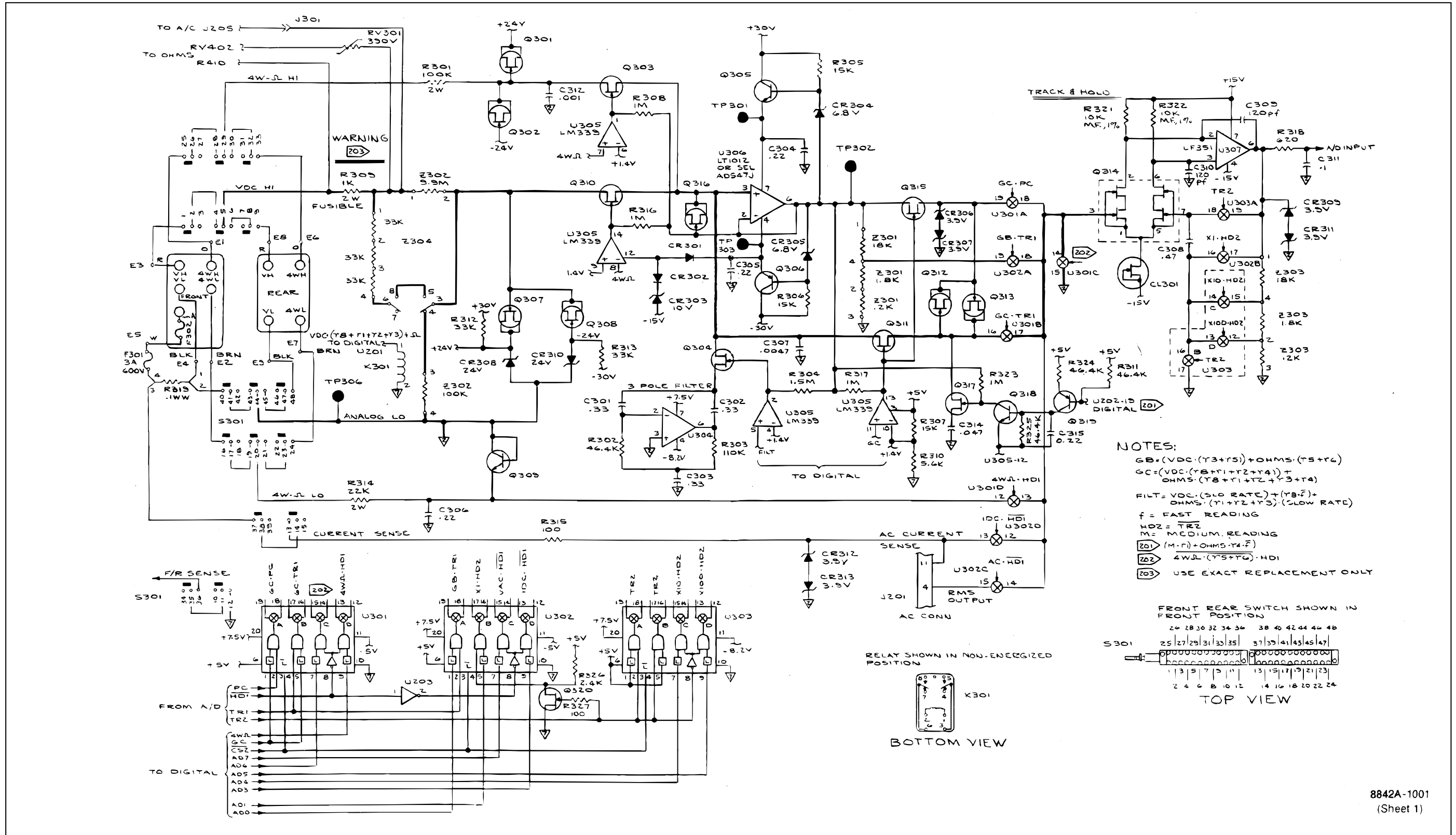
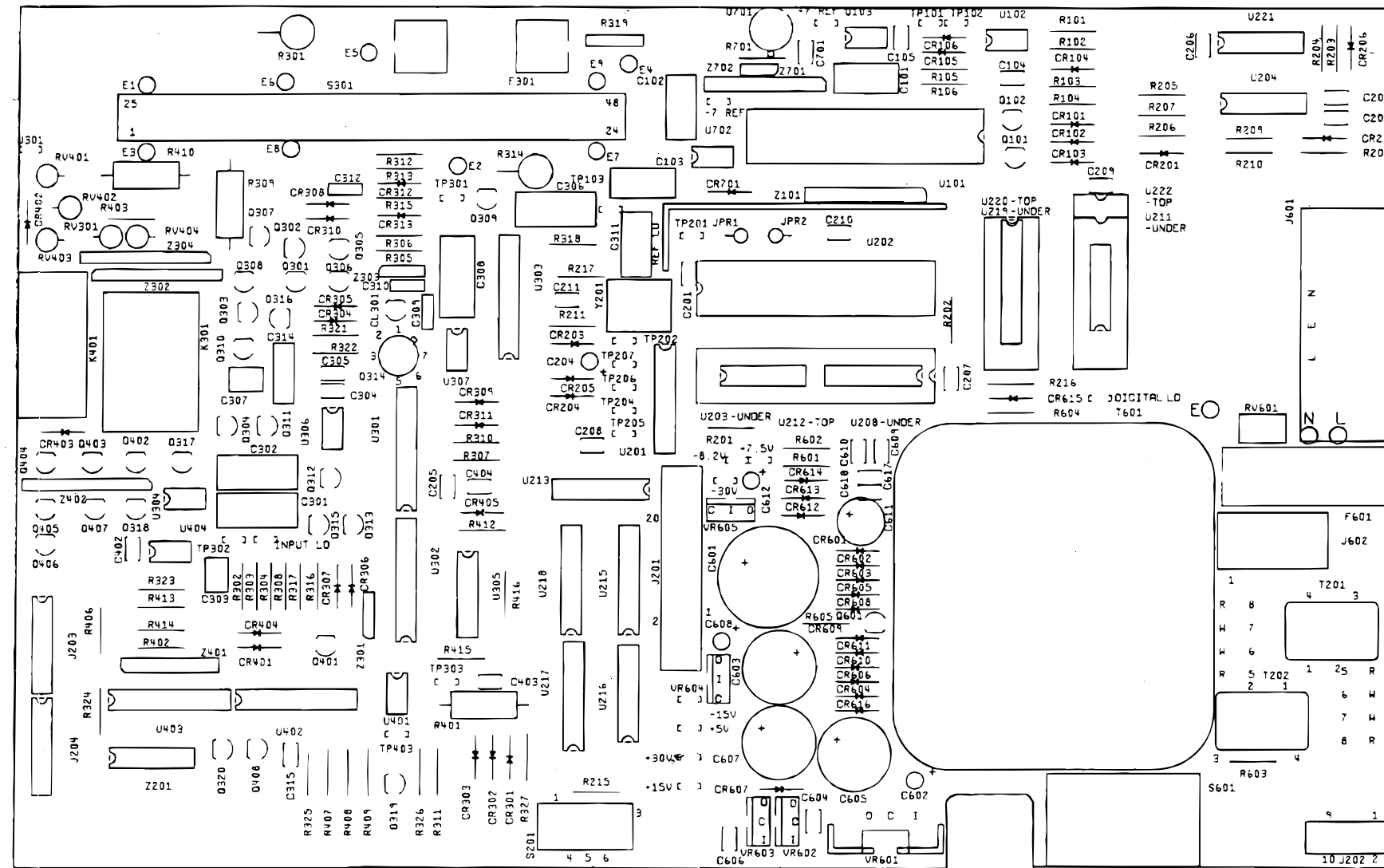
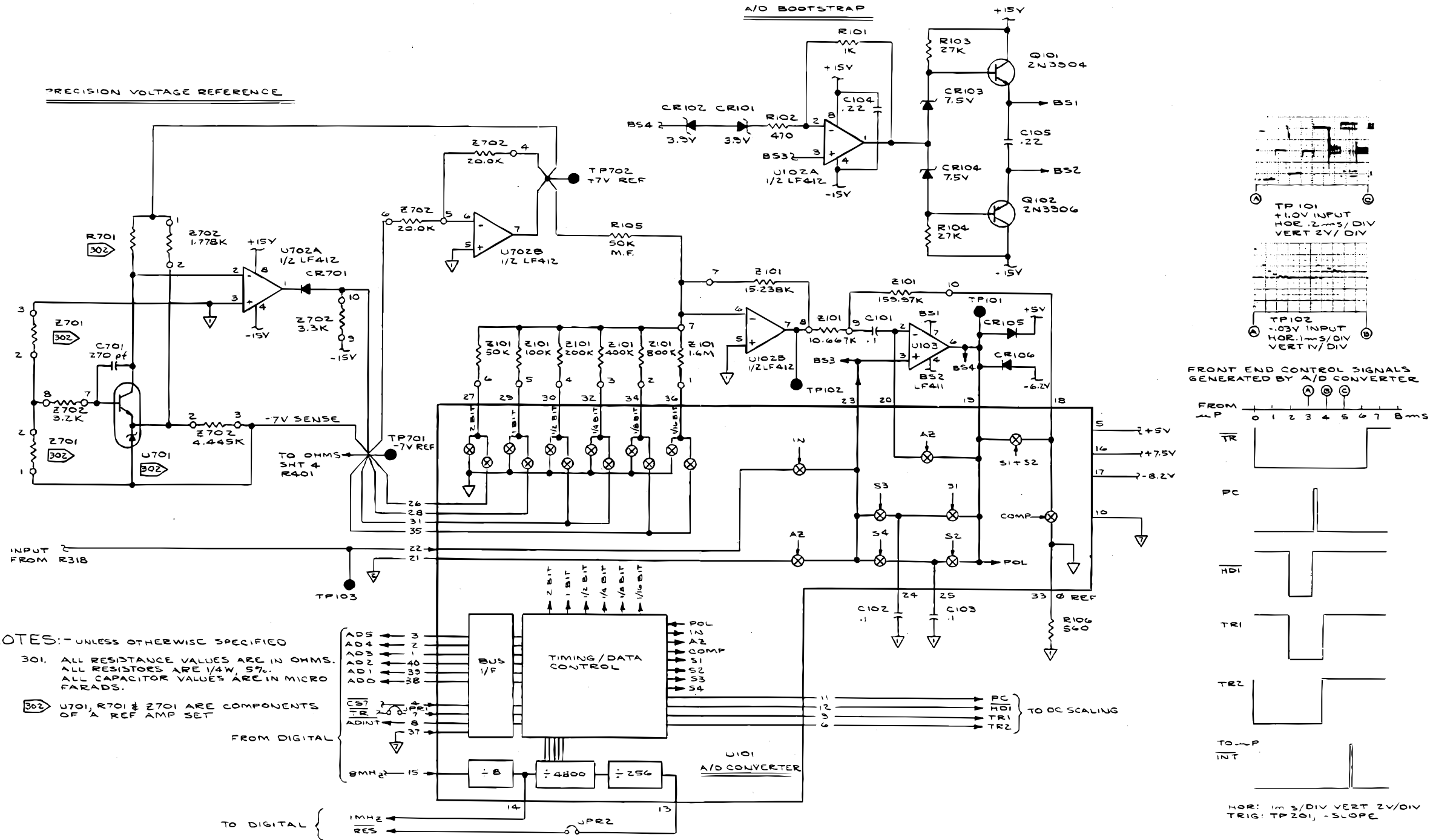

Figure 9-1. Main PCA, DC Scaling and F/R Switch (cont.)



8842A-1601

Figure 9-2. Main PCA, A/D Converter



8842A-1001
(Sheet 2)

Figure 9-2. Main PCA, A/D Converter (cont.)

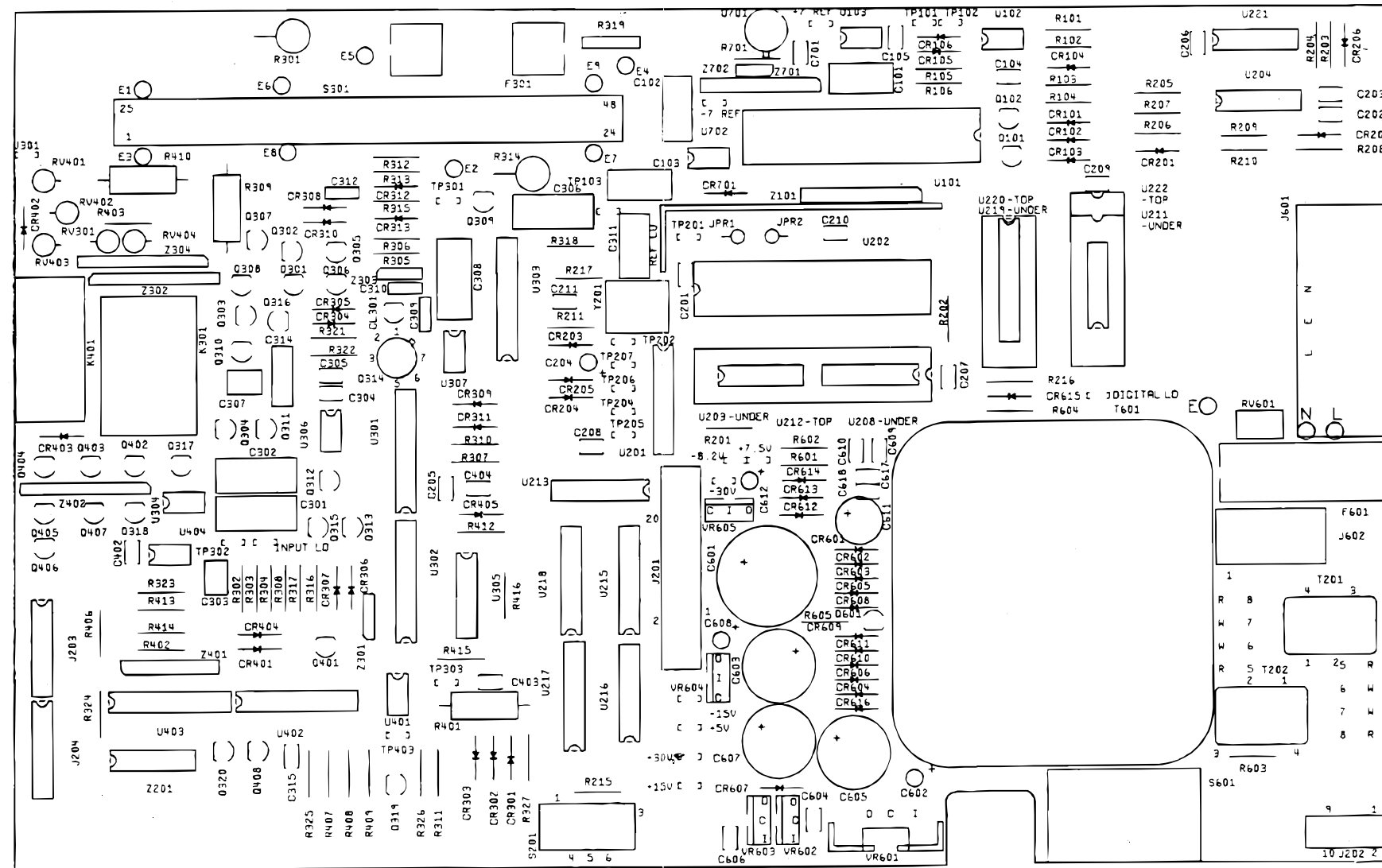

8842A-1601

f9-03_1.wmf

Figure 9-3. Main PCA, Ohms Current Source

NOTES:-

401. WHEN SIGNAL IS "TRUE," SWITCH IS CLOSED.

402 USE EXACT REPLACEMENT ONLY.

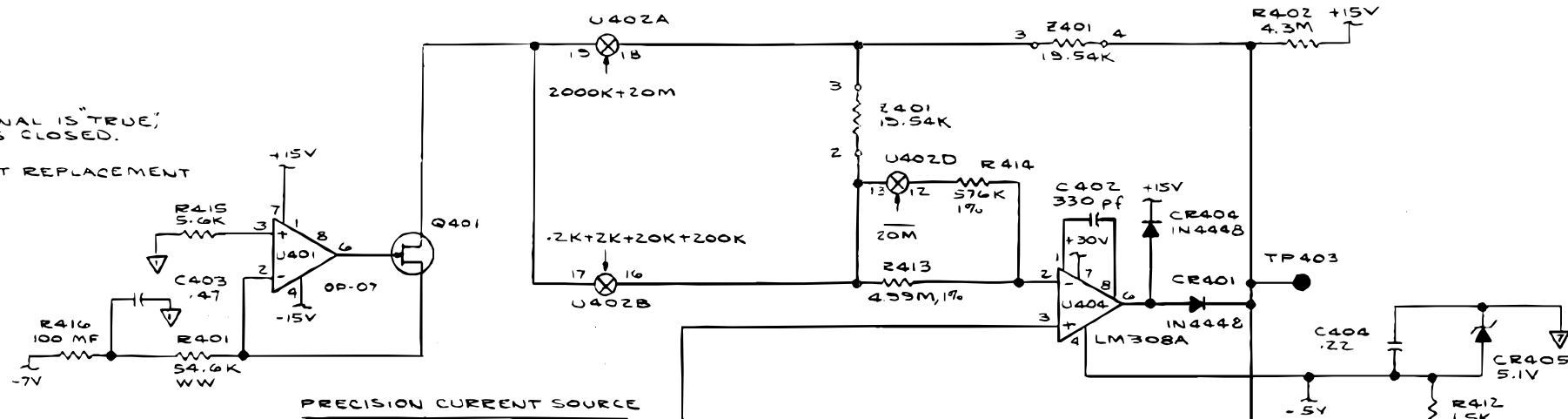

PRECISION CURRENT SOURCE

FIRST USED	LAST USED	UNUSED
U401	U404	
Q401	Q408	
R401	R416	R404, R405 R411
CR401	CR405	
RV401	RV404	
C401	C404	
K401	K401	

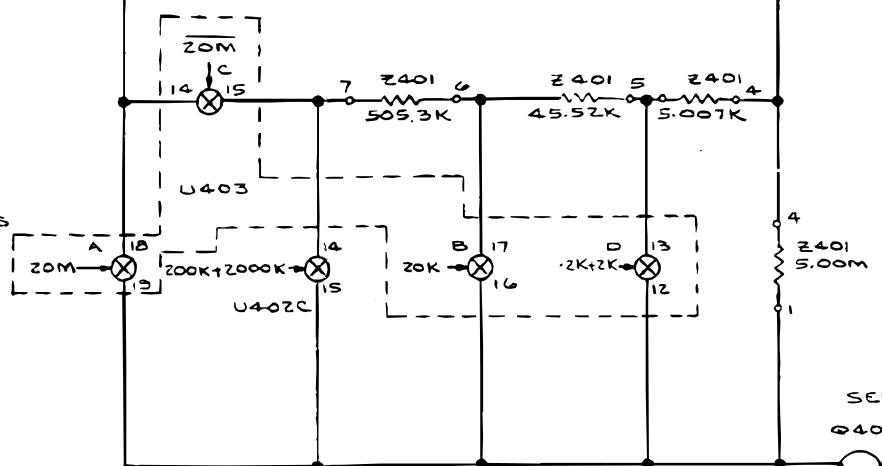
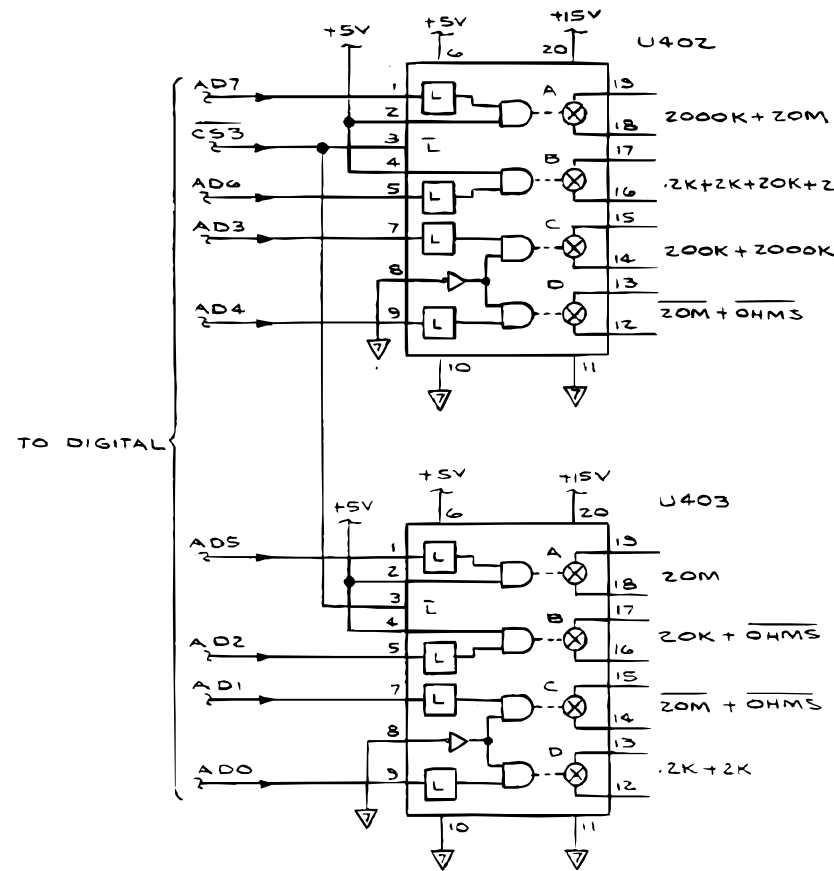

SEL ZN6520 (3 PL)

WARNING

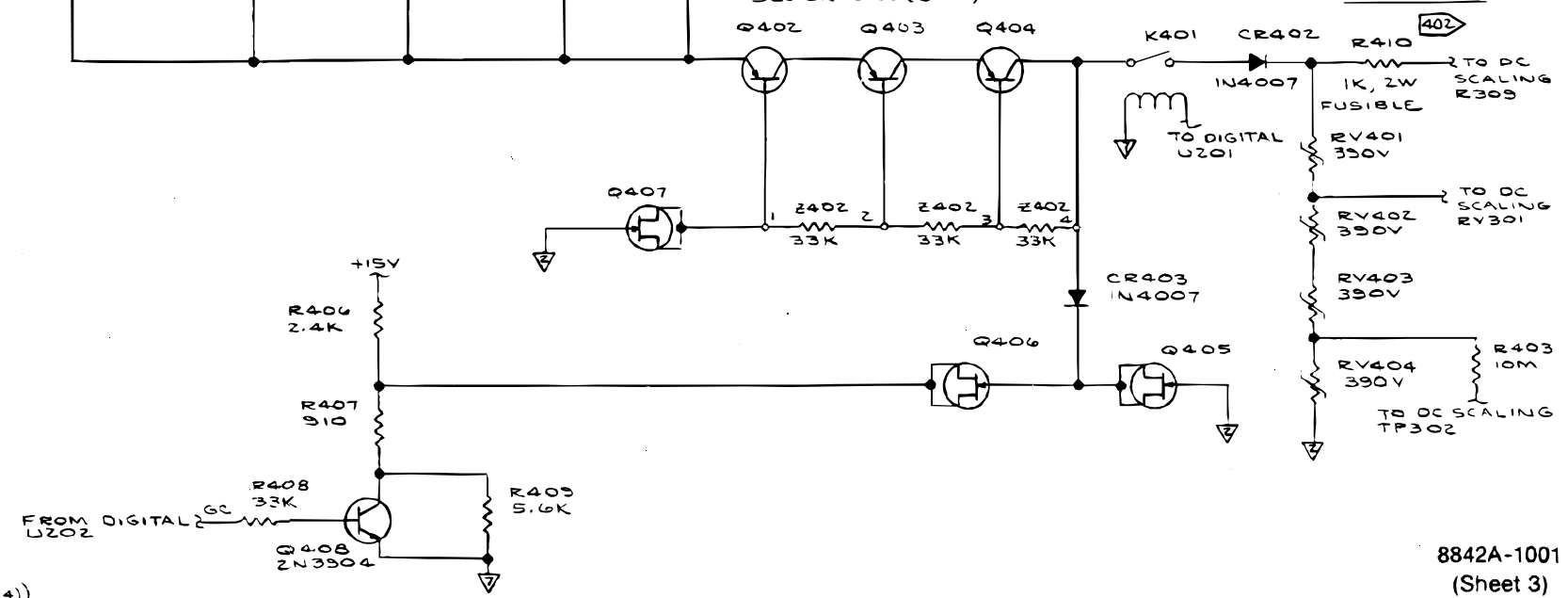

$$G_C = (V_{DC} \cdot (r_B + r_1 + r_2 + r_4)) + (OHMS \cdot (r_B + r_1 + r_2 + r_3 + r_4))$$

8842A-1001
(Sheet 3)

Figure 9-3. Main PCA, Ohms Current Source (cont.)

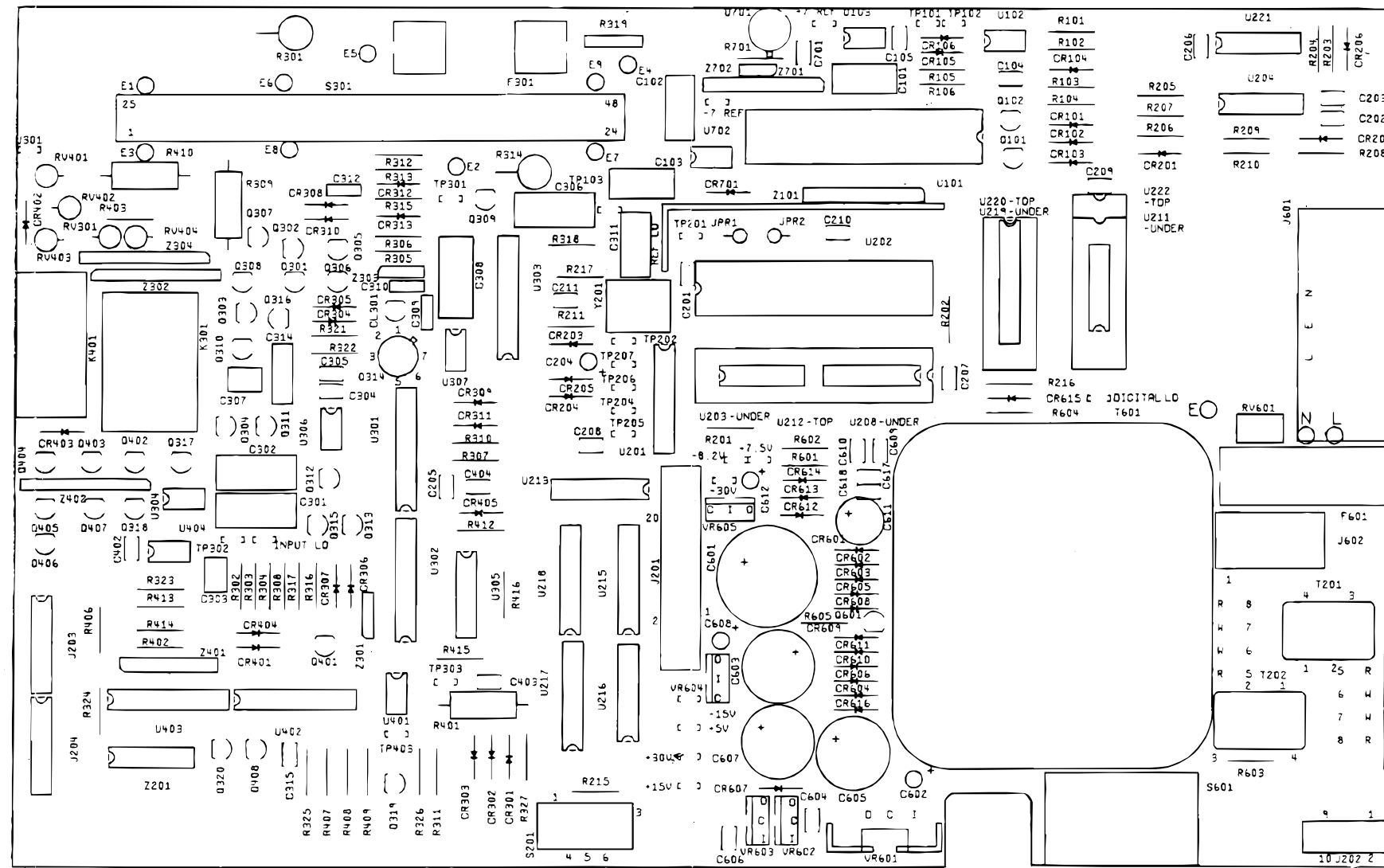

8842A-1601

Figure 9-4. Main PCA, Digital

19-04_1.wmf

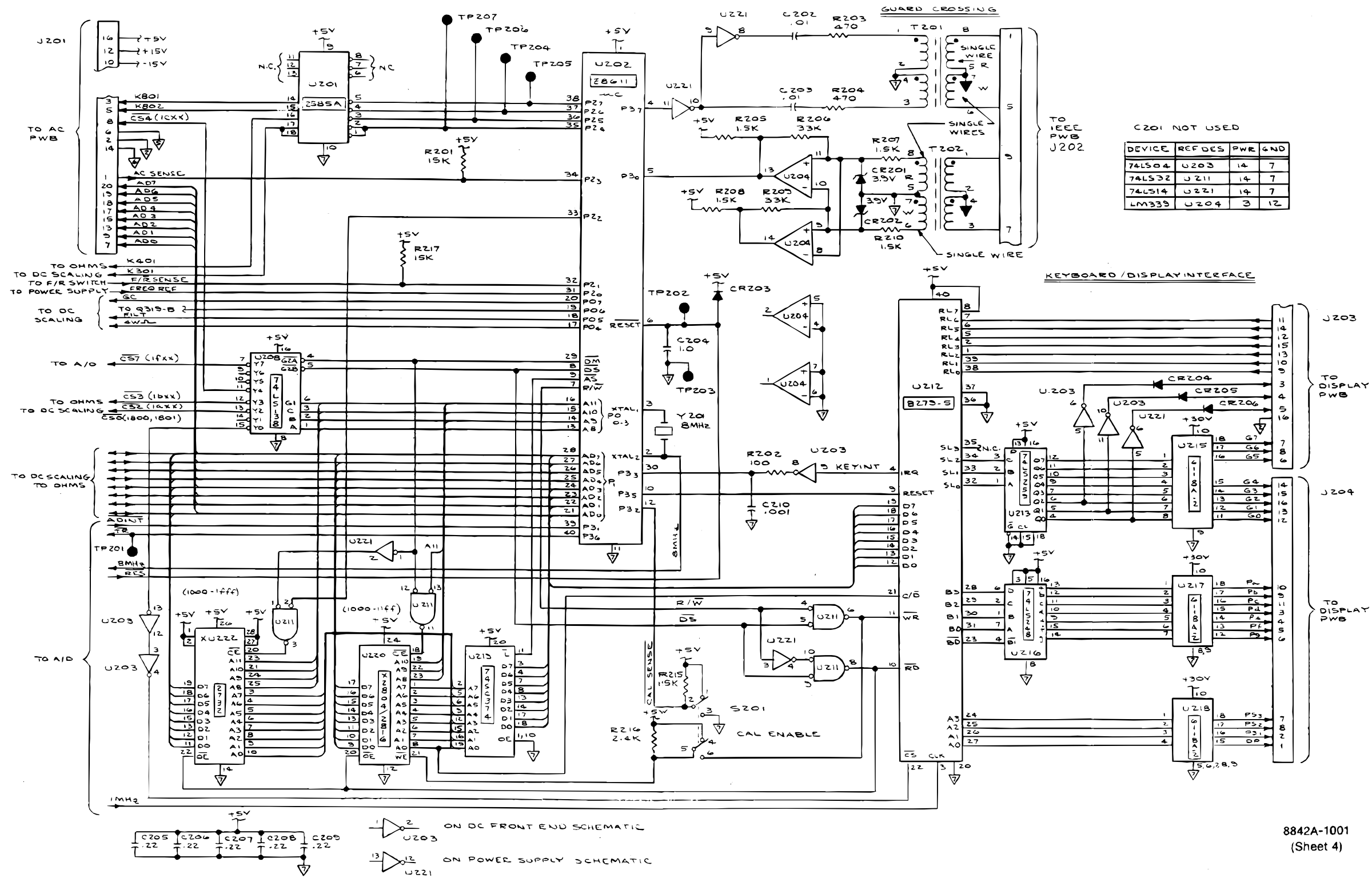

8842A-1001
(Sheet 4)

Figure 9-4. Main PCA, Digital (cont.)

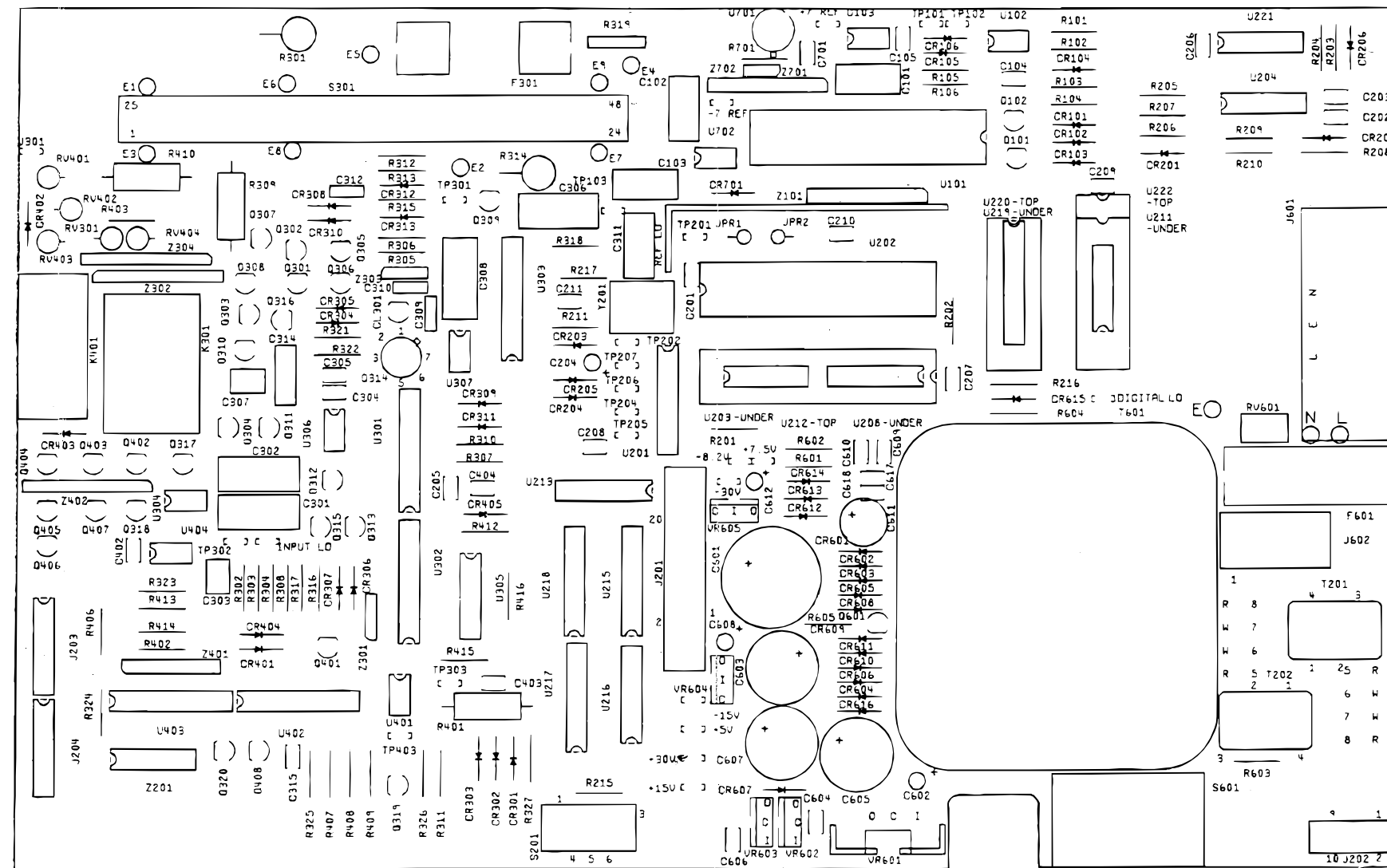

8842A-1601

f9-05_1.wmf

Figure 9-5. Main PCA, Power Supply

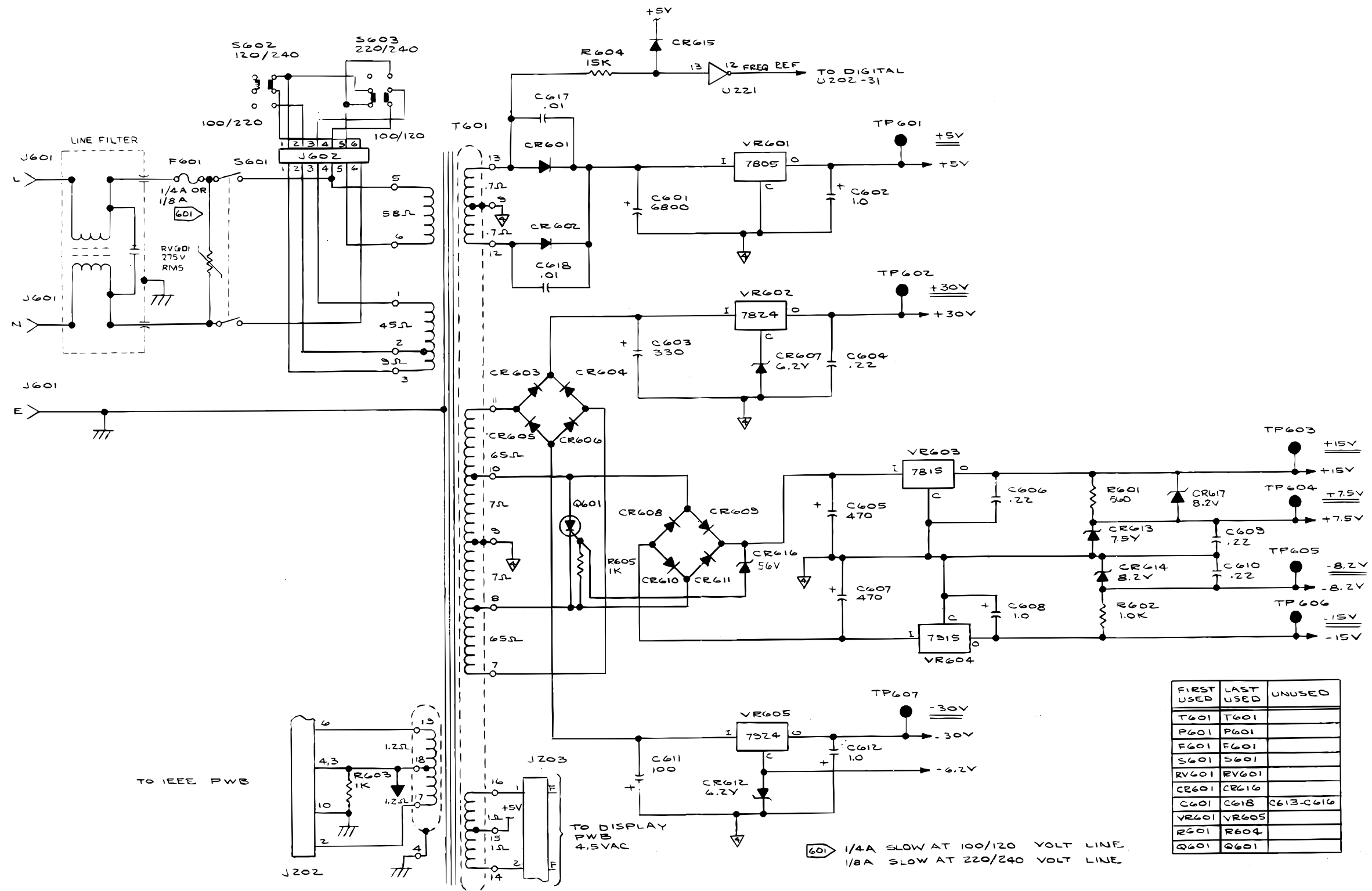

FIRST USED	LAST USED	UNUSED
T601	T601	
F601	F601	
S601	S601	
RV601	RV601	
CR601	CR616	
C601	C618	C613-C616
VR601	VR605	
R601	R604	
Q601	Q601	

8842A-1001
(Sheet 5)

Figure 9-5. Main PCA, Power Supply (cont.)

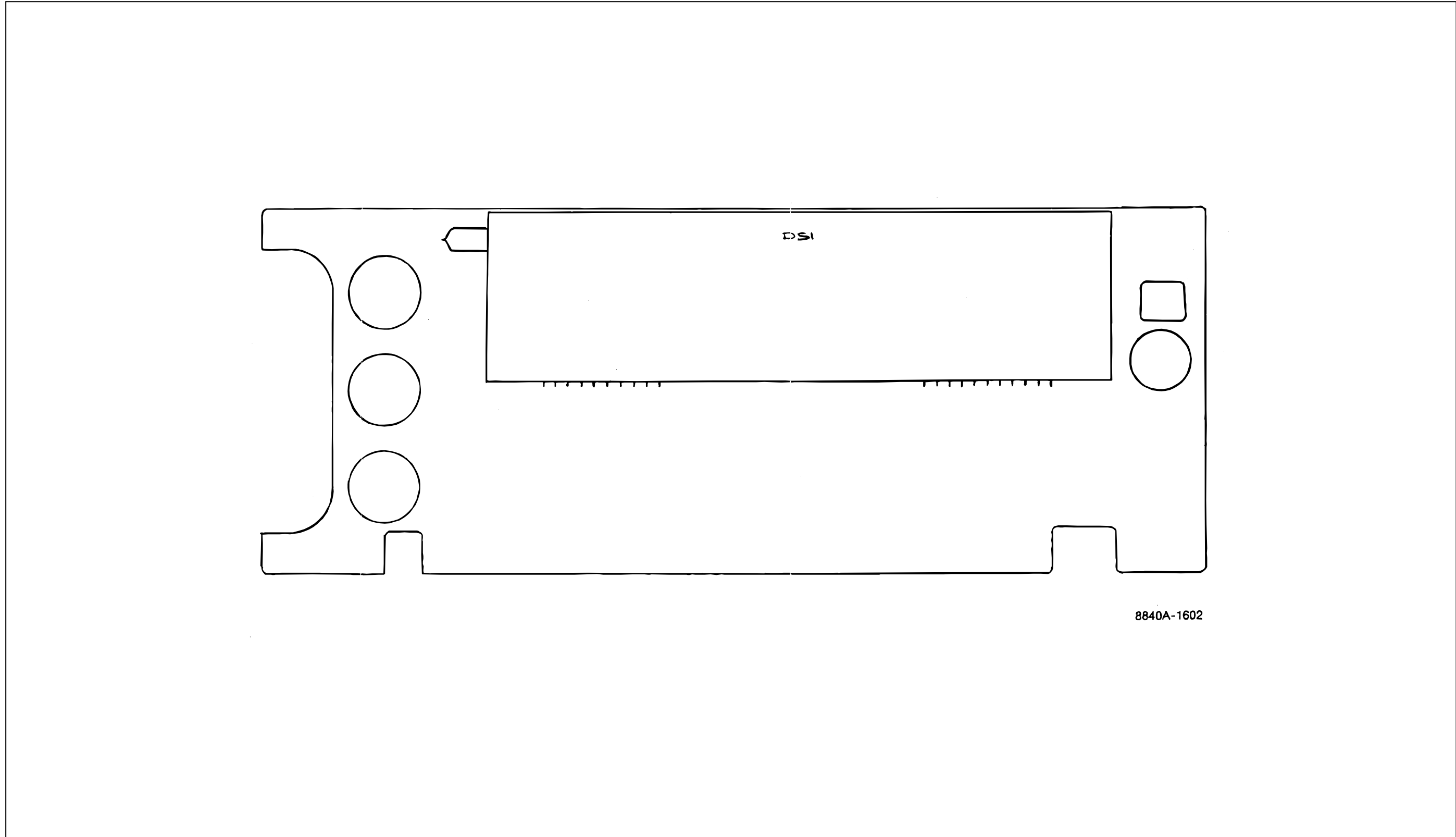
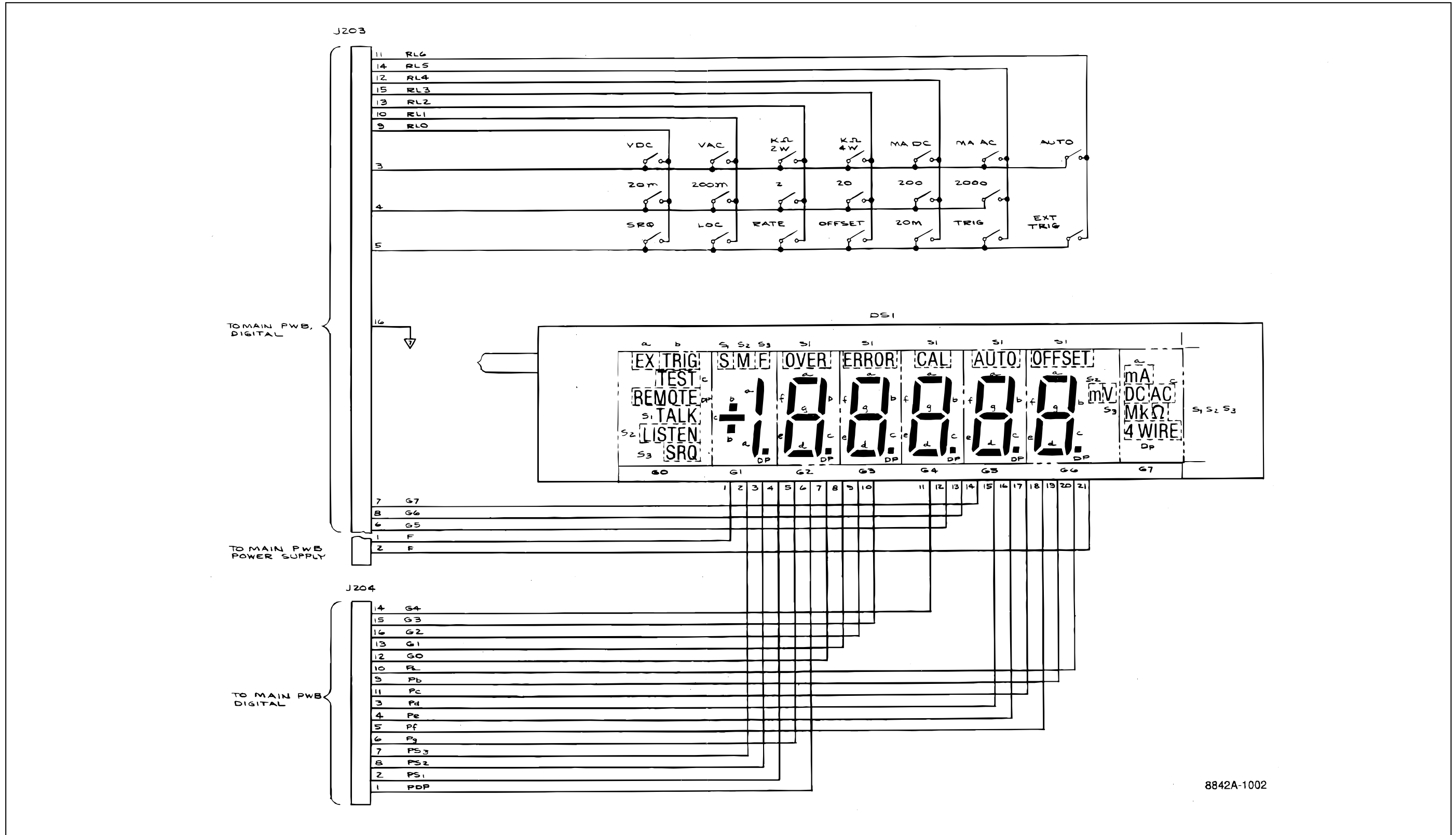

Figure 9-6. Display PCA

f9-06_1.wmf



8842A-1002

Figure 9-6. Display PCA (cont.)

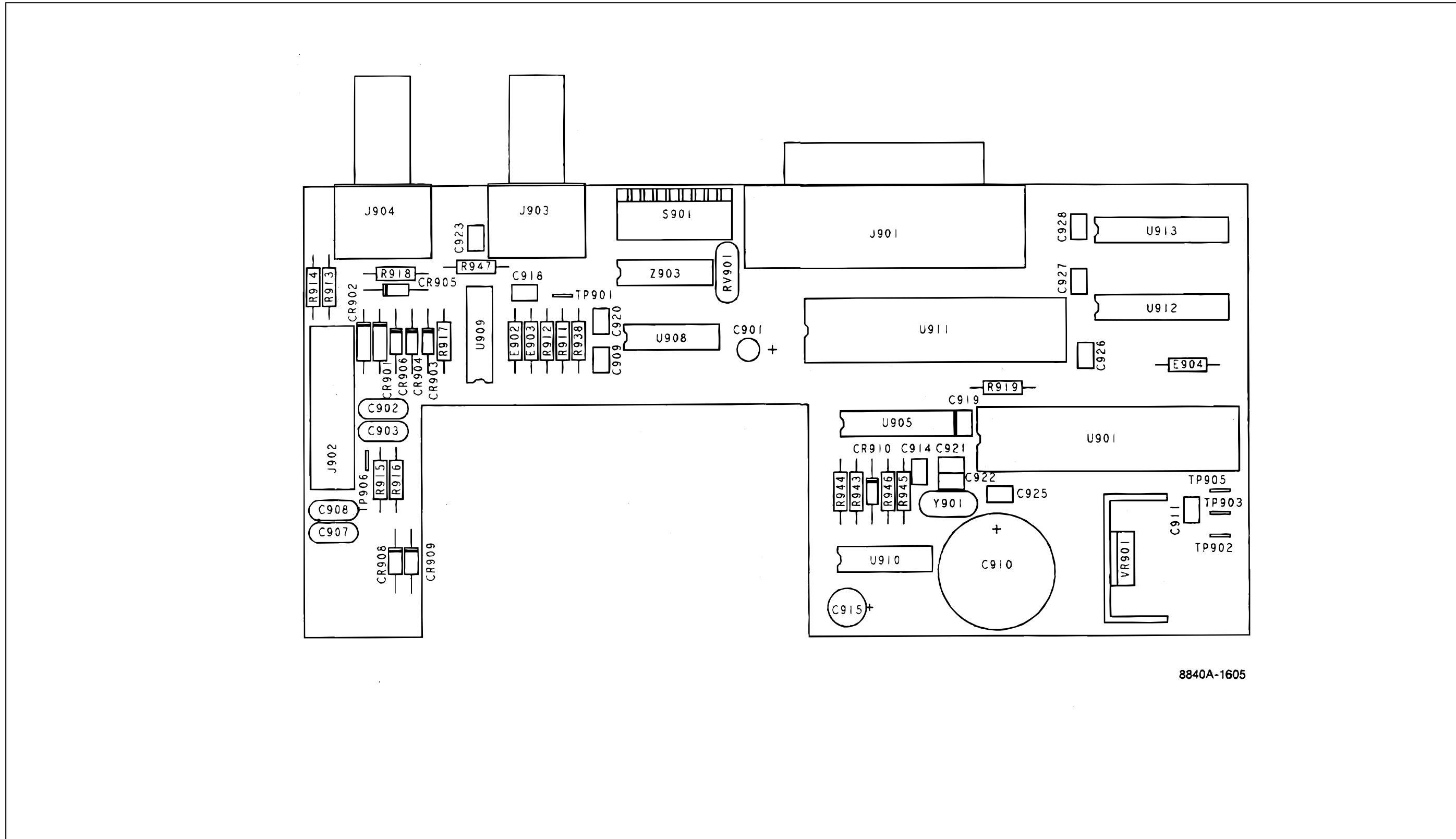

f9-07_1.wmf

Figure 9-7. IEEE-488 Interface PCA

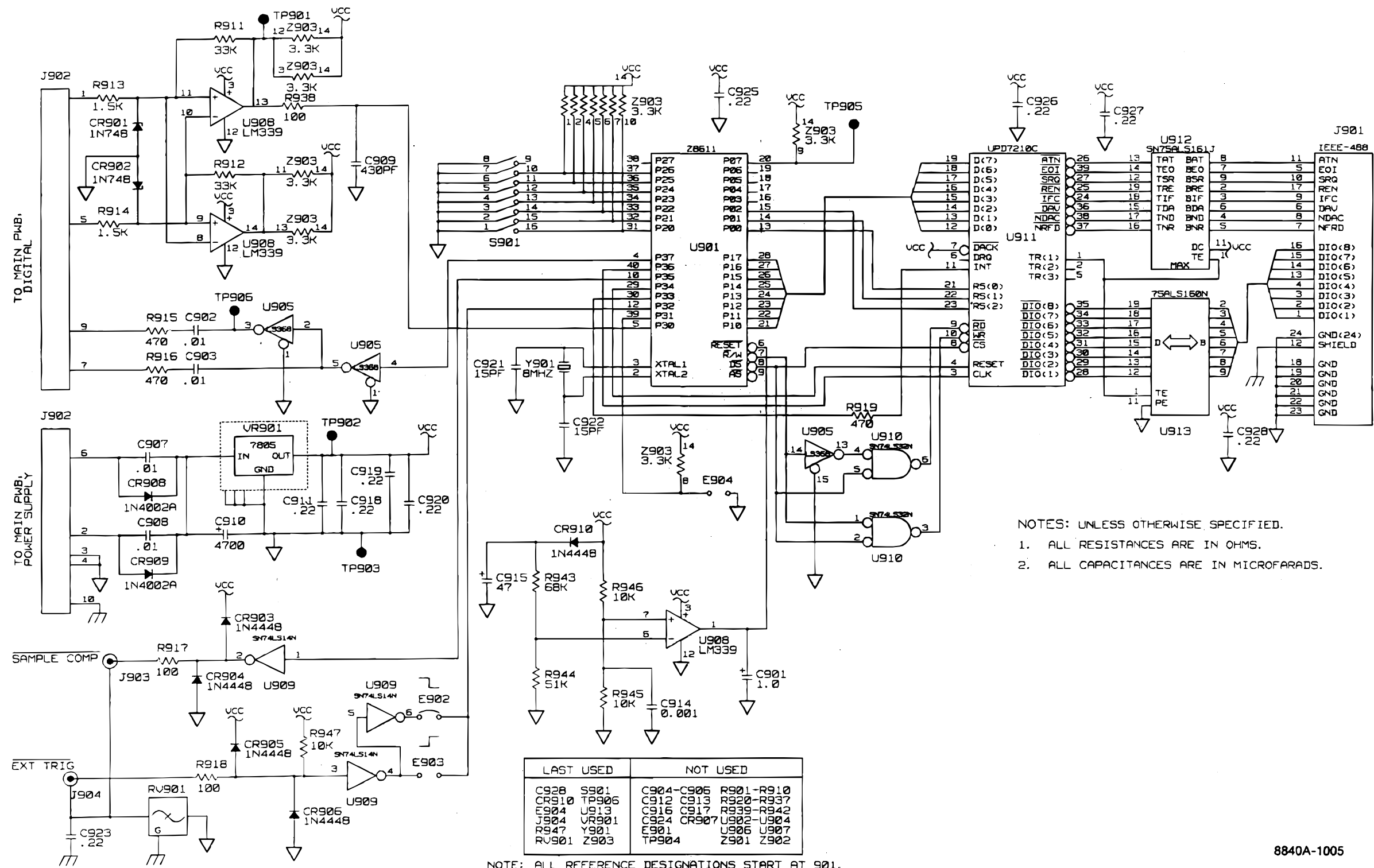

NOTE: ALL REFERENCE DESIGNATIONS START AT 901.

8840A-1005

Figure 9-7. IEEE-488 Interface PCA (cont.)

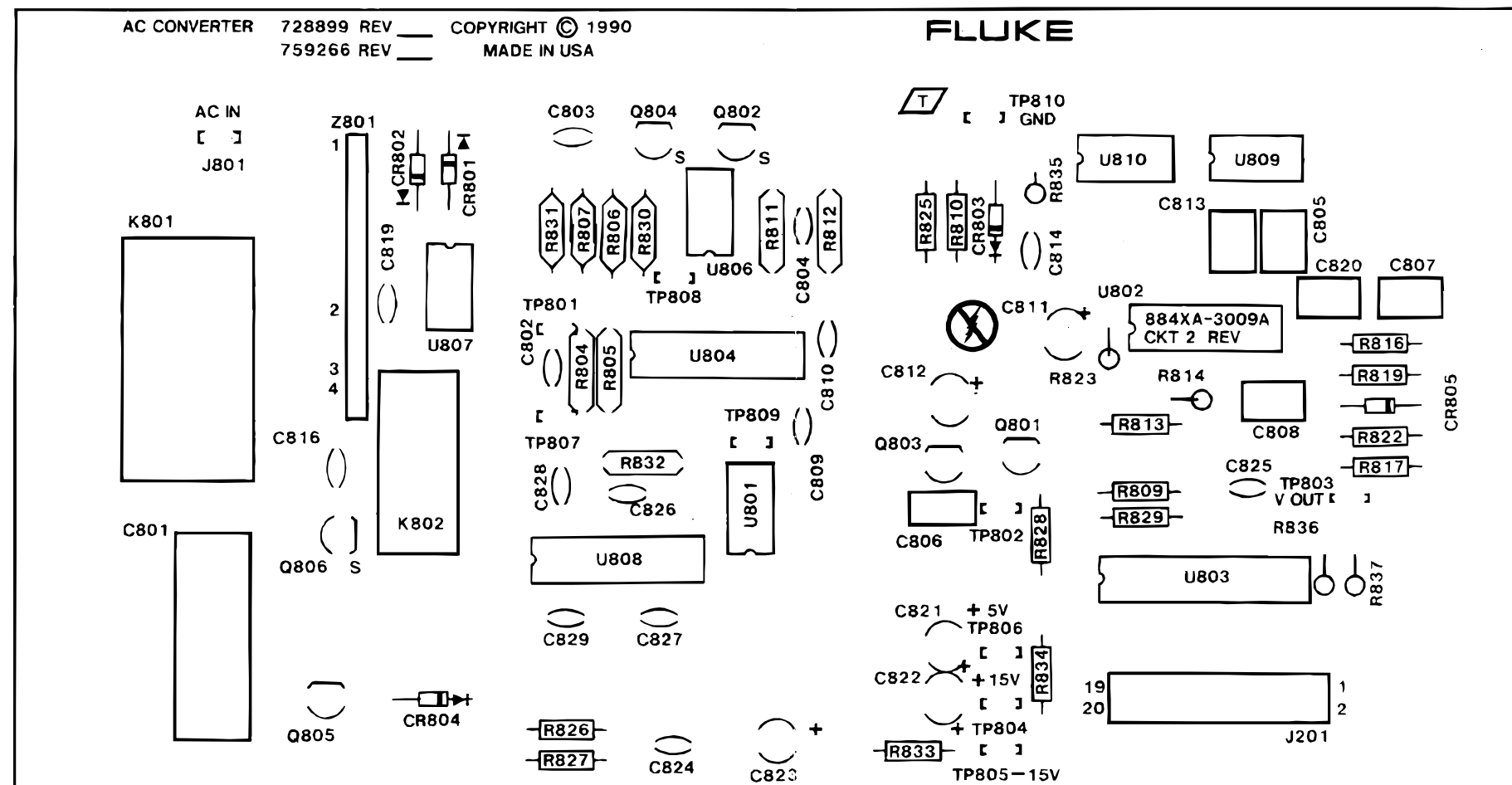

8842A-1609

Figure 9-8. IEEE-488 Interface PCA, Option -08

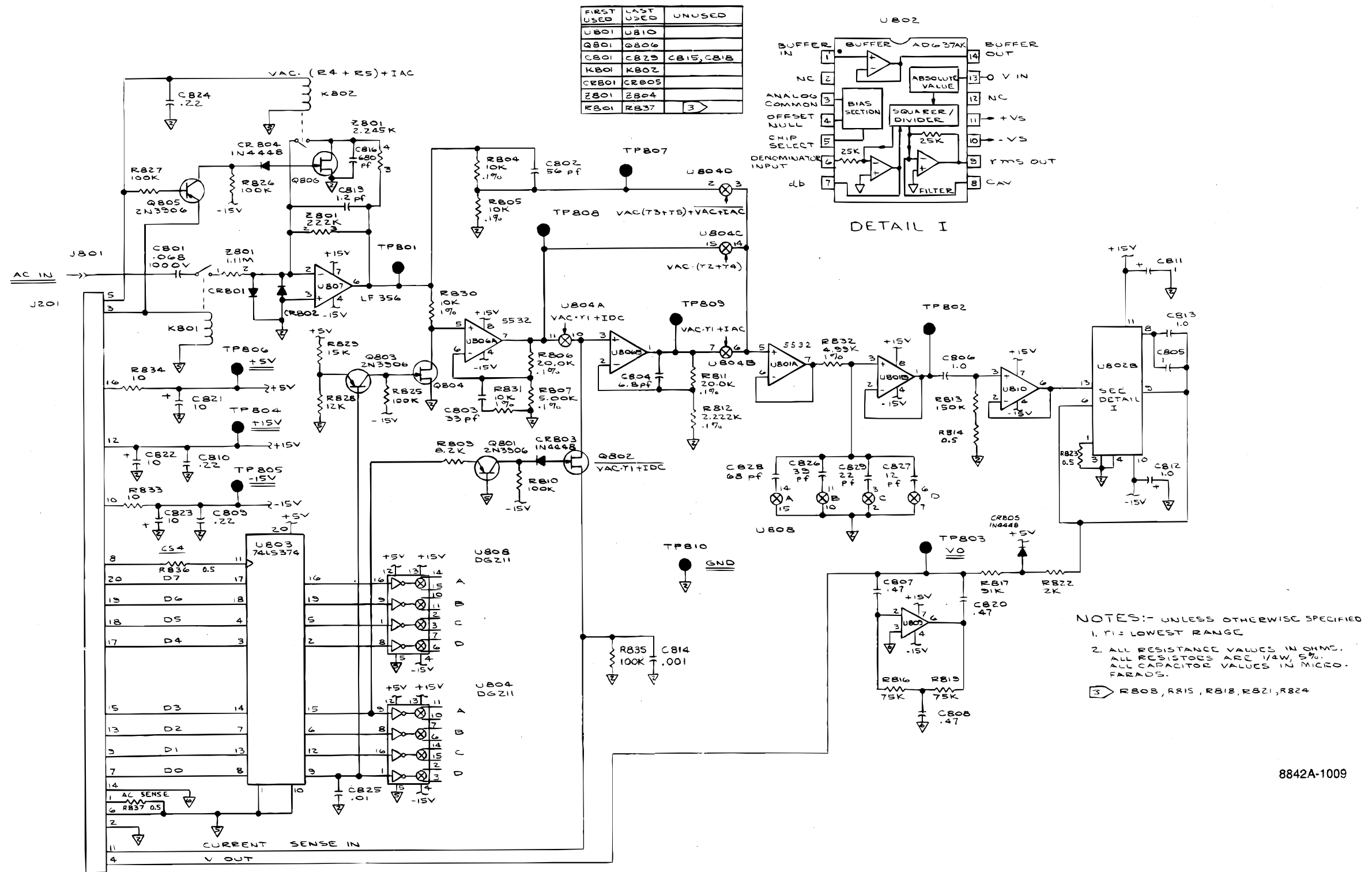

NOTES:- UNLESS OTHERWISE SPECIFIED
 1. R: LOWEST RANGE
 2. ALL RESISTANCE VALUES IN OHMS.
 ALL RESISTORS ARE 1/4W, 5%.
 ALL CAPACITOR VALUES IN MICRO-FARADS.
 3. R808, R815, R818, R821, R824

8842A-1009

Figure 9-8. IEEE-488 Interface PCA, Option -08 (cont.)